

HYUNDAI

HY SERIES



USER GUIDE

HYUNDAI

The engine exhaust from this product
contains chemicals known to cause cancer,
birth defects or other reproductive harm.

©2015 Energizer Power Equipment. All Rights Reserved.
Licensed by Energizer Corporation, United States of America.
HY_UG_EN_2015-06-12

We've got you covered!

Call us at 1-887-528-3772 if you have any questions

**REGISTER FOR YOUR WARRANTY AT
WWW.HYUNDAIPOWER.CA/WARRANTY.PHP
SEE CHAPTER 9 FOR MORE INFORMATION.**

SAVE THESE INSTRUCTIONS - This user guide contains important instructions for your product, that should be followed during installation and maintenance of the generator and batteries.

This user guide covers the safety, operation and maintenance procedures for the HY2000si and HY2800sei. All information in this publication is based on the latest product information available at the time of approval for printing.

No part of this publication may be reproduced without written permission.

If a problem should arise, please contact us by using the contact information at the end of this user guide.

It is important that this user guide be read and fully understood before operating the generator set. Failure to do so may cause serious injuries or equipment damage, and may void the warranty.

**THIS PRODUCT MEETS ALL
CERTIFICATION REQUIREMENTS FROM:**



SAFETY PRECAUTIONS	5
Operating instructions	5
AC Safety Guidelines	6
Maintenance Safety	6
Other Safety Hazards	7
LEARN ABOUT YOUR GENERATOR	8
Identification of Components	8
Pre-Operating Inspection	9
Fuel Level Check	10
Air Filter Check	11
USING YOUR GENERATOR	12
Initial Startup	12
Operating Your Generator	14
Shutting Off Your Generator	16
Maintaining Your Generator	17
DC Operation	19
MAINTENANCE	20
Maintenance Schedule	20
Changing the Engine Oil	21
Spark Plug Service	22
Transportation and Storage	23
TROUBLESHOOTING	24
SPECIFICATIONS	28
GLOSSARY	30
WARRANTY	32

Safety Precautions

This generator is designed to give safe and dependable service if operated according to instructions. Read and understand this user guide carefully before operating the generator, failure to follow instructions could result in serious injury or death.

Engines give off carbon monoxide, an odorless, colorless, poison gas. Breathing carbon monoxide can cause nausea, fainting or death. Do not operate the generator indoors or in a confined area and make sure the working environment is well-ventilated. The Engine Exhaust from this product contains chemicals known to the State of California to cause cancer, birth defects or other reproductive harm.

The exhaust and muffler becomes very hot during operation and remains hot for a while after stopping the engine. Make sure to read all warning labels. Be careful not to touch the muffler while it is hot. Let the engine cool before storing the generator indoors.

When storing gasoline or equipment with fuel in tank: Store away from furnaces, stoves, water heaters or other appliances that have a pilot light or other ignition source because they can ignite.

OPERATING INSTRUCTIONS

- Operate the generator according to instructions for safe and dependable service.
- Always perform a pre-operation inspection before starting the engine.
- Properly clean and maintain the equipment.
- Make sure to read and understand all warning labels.
- Gasoline is a highly flammable and explosive liquid. Make sure to refuel in a well ventilated area with the engine stopped.
- When refuelling the generator, keep it away from cigarettes, open flames, smoke, and/or sparks.
- This portable generator is not for use with gasoline/ethanol blends with over 15% ethanol.
- Connections for standby power to a building's electrical system must be done by a qualified electrician and must comply with all applicable laws and electrical codes. Improper connections may cause serious injuries to workers during power outages. When the utility power is restored, the generator may explode or cause fires

- Place generator at least 1 m (3.3 ft.) away from buildings or other equipment during operation.
- Operate the generator on a level surface. Tilting the generator may result in fuel spillage.
- Know how to stop the generator quickly and understand the operation of all controls. Never permit anyone to operate the generator without understanding the proper instructions.
- Do not operate the generator in rain or snow or allow any moisture to come in contact with the generator.
- Do not touch the spark plug while the generator is operating and shortly after the generator has been shut down.
- Keep children away from the generator when it is in use.

AC SAFETY GUIDELINES

Before connecting the generator to an electrical device, or power cord:

- Make sure that everything is in right working order. Faulty devices or power cords can lead to an electrical shock.
- Turn off the generator immediately if the device begins to operate abnormally. Then disconnect the device and investigate the problem.
- Make sure that the electrical rating of the device does not exceed that of the generator. If the power level of the device is between the maximum output power and the running power of the generator, the generator should not be used for more than 30 minutes.
- The connections from the generator to the household power supply should be done by a professional electrical technician. Improper connections may lead to a fire hazard or damages to the generator set.

MAINTENANCE SAFETY

- After any maintenance is performed, wash your body immediately using soap and clean water. Repeated exposure to lubricant may cause skin irritation.
- Do not clean the filter sponge with flammable fluids, such as gasoline, or explosion may occur.
- Turn off the generator set before performing any maintenance. Otherwise it can cause severe personal injury or death.
- Allow the generator set to cool down before performing any maintenance.
- Always wear safety glasses when cleaning the generator with air.
- Do not clean the generator set with a pressure washer because it may cause

damage to the generator set.

- Before working with batteries, ventilate the area, wear safety glasses, do not smoke and always disconnect the negative cable first and reconnect it last.
- Use rubber gloves when coming into contact with engine oil.
- Always stop the generator set before removing the oil filler cap.
- Only qualified maintenance personnel with knowledge of fuels, electricity, and machinery hazards should perform maintenance procedures.
- Moisture can damage the generator and can lead to an electric shock. Use and store in a dry environment.
- Lubricate all exposed metal parts regularly. See page 20 for maintenance schedule.

OTHER SAFETY HAZARDS

- To avoid breathing in poisonous carbon monoxide from the exhaust gases, adequate ventilation should be provided if the generator set is running in a partially enclosed space.
- If the generator set is stored outdoors, check all the electrical components on the control panel before each use.
- Generators vibrate in normal use. During and after the use of the generator, inspect the generator as well as extension cords and power supply cords connected to it for damage resulting from vibration. Have damaged items repaired or replaced as necessary. Do not use plugs or cords that show signs of damage such as broken or cracked insulation or damaged blades.
- For power outages, permanently installed stationary generators are better suited for providing backup power to the home. Even a properly connected portable generator can become overloaded. This may result in overheating or stressing the generator components, possibly leading to a generator failure.
- When this generator is used to supply a building wiring system: Generator must be installed by a qualified electrician and connected to transfer equipment as a separately derived system in accordance with the National Electrical Code, NFPA 70. The generator shall be connected through transfer equipment that switches all conductors other than the equipment grounding conductor. The frame of the generator shall be connected to an approved grounding electrode.

Pre-Operating Inspection

WARNING

Ensure that the generator is on a level surface and the engine is turned off before inspection.

ENGINE OIL INSPECTION

Use high-detergent, premium quality, 4-stroke engine oil. Select the appropriate viscosity for the average temperature in your area.

1. Loosen the cover screws and remove the maintenance cover (refer to fig.).
2. Remove the oil filler cap and wipe the dipstick clean (refer to fig.). Check the oil level by inserting the dipstick into the filler neck without rotating it.
3. If the level is low, fill to the upper limit of the oil filler neck with the recommended oil.
4. Reinstall the maintenance cover and tighten the cover screws.

NOTICE

The oil alert system is designed to prevent engine damage caused by an insufficient amount of oil in the crankcase. Before the oil level in the crankcase falls below a safe limit, the oil alert system will automatically shut down the engine. If the oil alert system shuts down the engine, the oil alert indicator will come on when you operate the starter and the engine will not run. If this occurs, add engine oil.

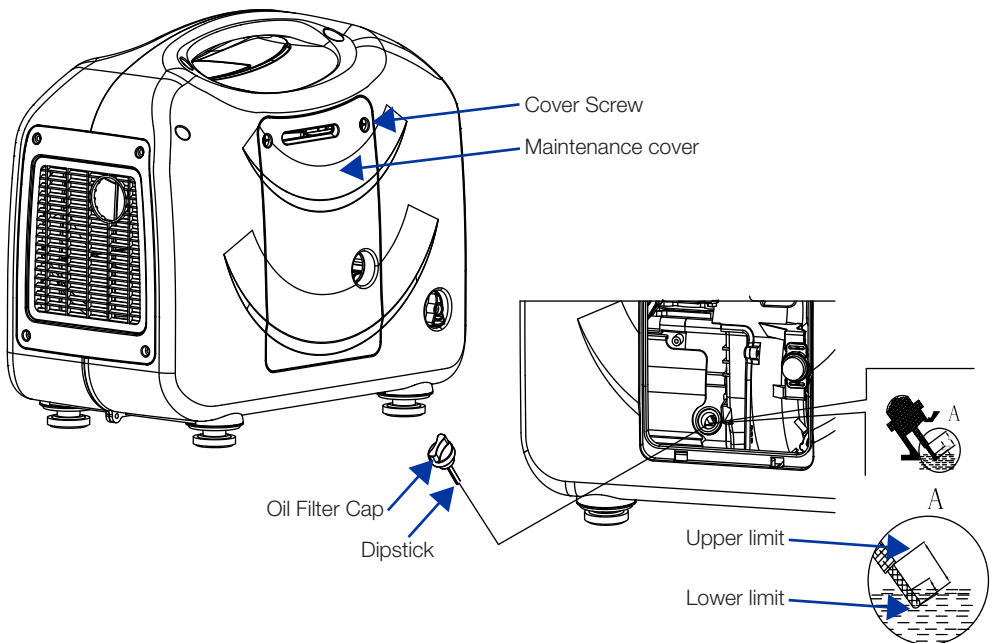

Fuel Level Check

1. Check fuel level display located on top of generator gas tank.
2. Refill the fuel tank if the level is low. Refuel carefully to avoid spilling fuel. Do not fill above the upper limit mark (Refer to Fig.).

CAUTION

- Gasoline is highly flammable and explosive. Keep the engine away from heat, spark the open flame.
- Refuel in a well-ventilated area with the engine stopped.
- Only handle fuel outdoors.
- Wipe up spills immediately.
- Avoid getting dirt, dust, or water in the fuel tank.
- Never use an oil/gasoline mixture or dirty gasoline.
- Do not use fuel containing alcohol. Fuel system damage or engine performance problems will result from the use of fuels that contain alcohol.
- Avoid repeated or prolonged contact with skin or breathing of fuel vapor.

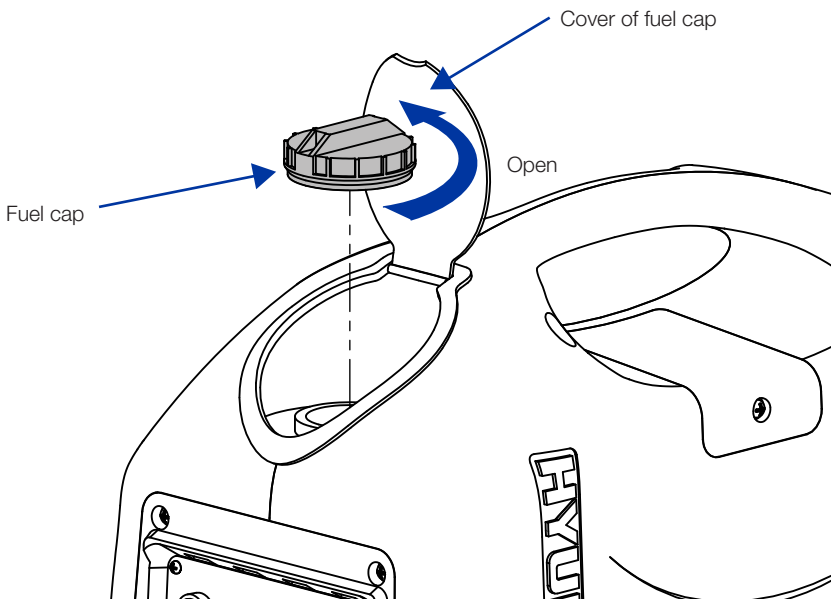

Air Filter Check

WARNING

Never run the engine without the air filter. Rapid engine wear will result from contaminants, such as dust and dirt, being drawn through the carburetor into the engine.

1. Remove air filter cover and sponge.
2. Inspect filter sponge for dirt and debris.
3. Clean filter sponge by soaking in gasoline, ring out before reinstalling.
4. Replace air filter every 24 months or when necessary.

TO CLEAN THE SPONGE:

- Clean air filter sponge in warm soapy water or non-flammable detergent. Allow to dry before reinserting into generator.
- Dip sponge in clean engine oil and squeeze out all excess oil. The engine will produce excess smoke if too much oil is left in the filter.
- Wipe dirt off the air filter cover using a moist rag.

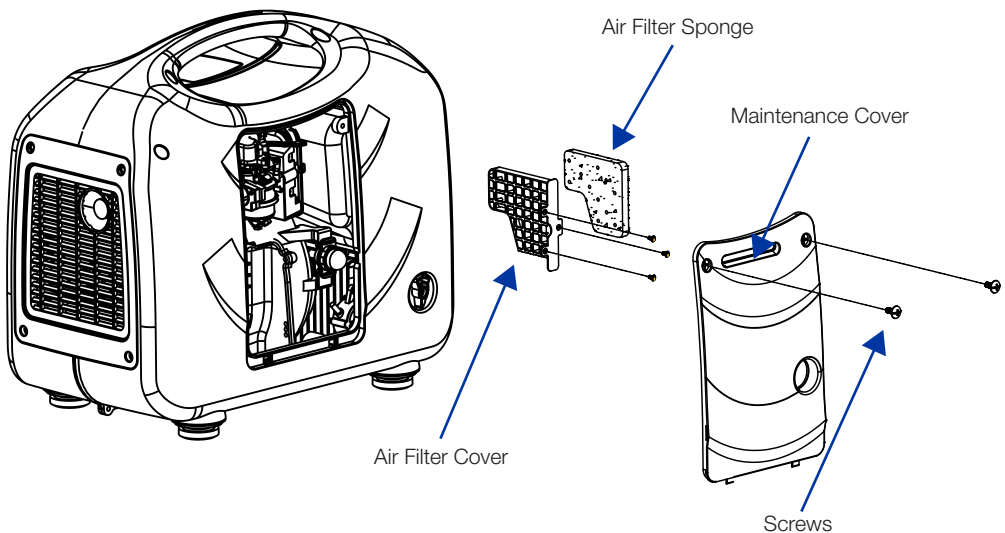

Initial Startup

WARNING

We know you're excited to get using your generator. Please be sure to follow the setup, operation, and shut off instructions below thoroughly to ensure the best lifespan for your generator.

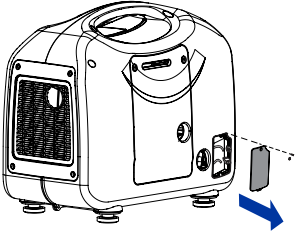

1. **(HY2800SEI ONLY)** Setup the Battery: Remove the Battery Access Panel from the unit by unscrewing the screw at the top and releasing the panel.

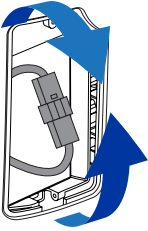

2. **(HY2800SEI ONLY)** Connect the Battery: locate and connect the loose connectors from the battery wiring harness and the main wiring harness. The battery is now connected to the unit.

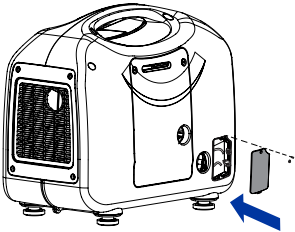

3. **(HY2800SEI)** Re-install the Battery Access Panel onto the unit. Ensure the screw is fastened properly.

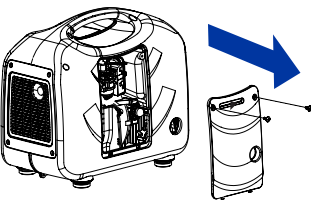

4. Remove the main engine access panel from the unit by unscrewing the 2 screws at the top and middle of the unit.

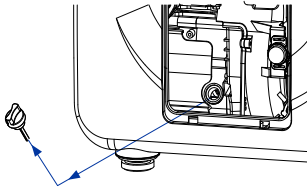

5. Locate, unscrew, and remove the Oil Dipstick, exposing the internal engine compartment. Be sure not to allow any dust or debris near the engine during this time.

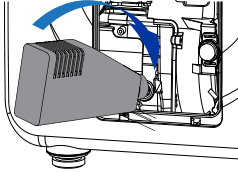

6. Pour in the full contents of the 450 mL oil bottle provided with your unit, or fill to the full mark located on the dipstick.

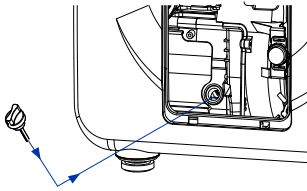

7. Re-install the Oil Dipstick and fasten tightly. Wipe away any excess oil. For best results, drain and refill the engine oil after the first 20 hrs of use, and every 50 hrs thereafter.

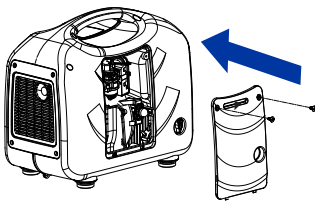

8. Re-install the Engine Access Panel onto the unit, ensuring that all 2 screws are fastened properly.

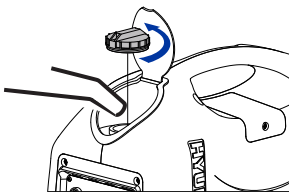

9. Remove the fuel cap, exposing the fuel tank. Be sure not to allow any dust or debris near the engine during this time. Pour 91 octane unleaded gasoline into fuel tank, add Ethanol Shield as directed on bottle, and replace the fuel cap.

Operating Your Generator

Before using generator, a ground wire must be connected to the ground terminal. The Ground terminal is located on the Front Panel. Before using the ground terminal consult a qualified electrician.

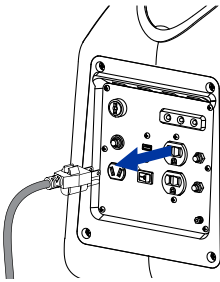

1. Disconnect all devices from the generator.

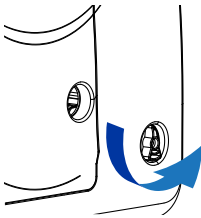

2. Open the fuel valve by turning the fuel valve knob from “off” to “on”. Make sure the valve is turned all the way, to ensure that the valve has been fully opened for fuel to pass through.

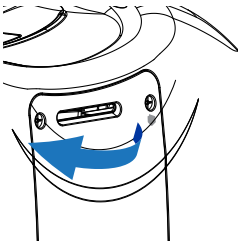

3. Turn choke to “START / CLOSED” position. Leave the choke in the “RUN / OPEN” position if the generator is still warm from recent use, or if the air temperature is higher than 50°F (10°C).

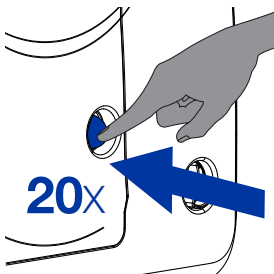

4. Locate and press primer bulb 15-20 times to move fuel through the lines and into the engine. Note: This step is only necessary when the engine is cold

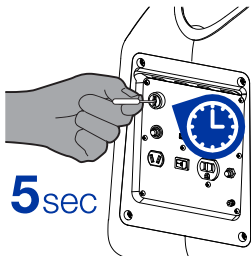

- 5. (HY2800SEI ONLY, FOR HY2000SI AND MANUAL START PROCEED TO 6)** Turn Power switch to “Start” for 5 seconds to start engine. If the engine does not start, the battery may be dead, proceed to step 6 to start the engine. Running the engine charges the battery.

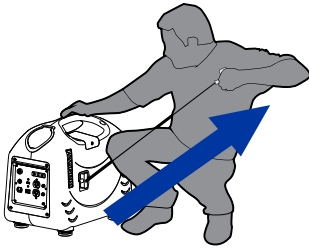

- 6.** Pull Recoil handle until engine starts. Several pulls may be required until engine starts. Do not release the pull cord at the end of a pull, this will damage the recoil assembly. Bring the pull handle back down to the unit by hand.

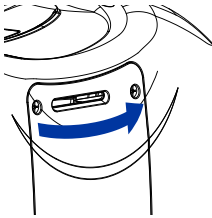

- 7.** Once the generator has started, wait at least 30 seconds for it to warm up, and then you may slowly open the choke lever until it is in the “RUN / OPEN” position.

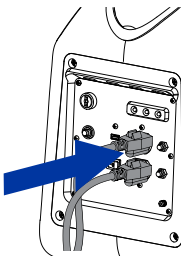

- 8.** Connect all of your devices to the generator.

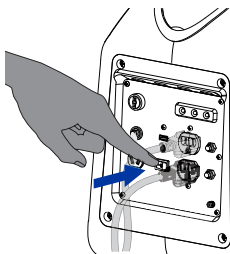

- 9.** Turn EcoMode switch to “On”. This will reduce the output to a level where the generator will only produce enough power for the connected devices. The reduction of extra, unused power saves fuel.

Shutting Off Your Generator

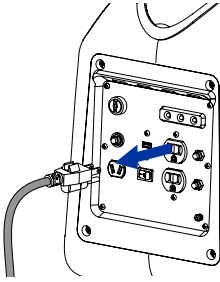

1. Disconnect all devices from the generator.

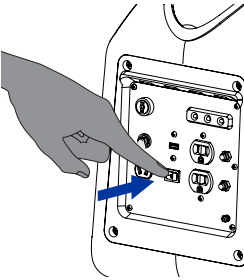

2. Turn EcoMode switch to "Off".

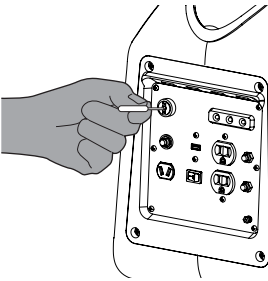

3. Turn Power switch to "Off".

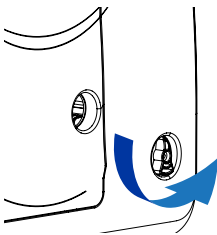

4. Close the fuel valve by turning it to "Off".

To stop the engine in an emergency, turn the engine switch "OFF". Always connect the ground terminal at the front panel to the ground (earth) to prevent electrical shock.

Maintaining Your Generator

Connections for standby power to a building's electrical system must be done by a qualified electrician and must comply with all applicable laws and electrical codes. Improper connections may cause serious injuries to electrical worker during power outages. Additionally, the generator may explode or cause fires when the utility power is restored.

WARNING!

- To prevent electrical shock from faulty appliances, the generator should be grounded.
- Limit operation requiring maximum power to 30 minutes.
- Do not exceed the current limit specified for any one receptacle.
- Do not connect the generator to a household circuit.
- Do not modify or use the generator for other purposes than it is intended for.
- Be sure to use properly isolated cable when an extension cable is required.
- Limit length of extension cables to 60 m for cables of 1.5 mm wire thickness and 100 m for cables of 2.5 mm wire thickness.
- Keep the generator away from other electric cables or wires, such as a distribution network.
- The DC receptacle can be used while the AC power is in use. If you use both at the same time, be sure not to exceed the total power for AC and DC.
- Before connecting a device to the generator, make sure the electrical rating of the device does not exceed the electrical rating of the generator.
- Be sure the device is turned off before plugging in the power cord.
- When the output indicator light (green) is OFF, and the overload indicator light (red) is ON, flip the engine switch to the STOP position, stop the engine at once and then start the engine again.

NOTICE

- Under normal operating conditions, the output indicator light (Green) will be ON
- When a connected device draws high startup power the overload and output indicator light may briefly illuminate, but this is to be expected. Once the device starts up the overload indicator light will shut off and the output light will remain green. If the generator is overloaded (in excess 100W), or if there is a short circuit in a connected device, the overload indicator light (Red) will be ON.
- Substantial overloading that continuously lights the overload indicator light (red) may damage the generator. Marginal overloading that temporarily lights the overload indicator (red) may shorten the service life of the generator.

- If the oil level falls below a safe limit, the low oil indicator light (Red) comes on and the engine will be automatically stopped. If the engine stops or the low oil indicator light comes on when you pull the starter grip, check the engine oil level before troubleshooting in other areas. (Refer to Fig.)
- A hot engine will not start if there is too much gasoline in the cylinder. If this happens, wait for 5 to 10 minutes for the engine to cool down before starting.
- The engine will stop automatically when it is out of gasoline.
- When the output indicator light (green) does not light and the overload indicator light (red) lights instead, set the engine switch to STOP, stop the engine at once and then start the engine again.
- If the engine stops and cannot be restarted, check oil level before troubleshooting other possibilities.
- Ensure ECON switch is off before turning on any connected devices.

DC Operation

Do not leave generator unattended when charging batteries. Stop charging when the voltage of the batteries is above 16V. Failure to monitor charge level may result in damage to the battery or personal injury.

The DC receptacle may be used while the AC power is in use.

The overloaded DC circuit will trip the DC circuit protector. If this happens, disconnect the DC load before pushing in the circuit protector to resume operation.

1. Set the ECON switch to the OFF position.
2. Connecting the battery charging cable.
 - Connect the battery charging cable to the battery.
 - Plug the charging wires into the DC outlet of the generator.
 - Connect the positive (Red) terminal of the charging wire to the positive (+) battery terminal and negative (black) terminal of the charging wire to the negative (-) battery terminal.
3. Turn the start switch to the ON position.
4. Set the DC breaker switch to ON position (refer to fig.).
5. Start the generator.

NOTICE

- The DC socket is only used for charging a 12V battery.
- When using the DC socket, turn the ECON switch to the OFF position.

WARNING

- The battery gives off explosive gases; keep sparks, flames and cigarettes away. Provide adequate ventilation when charging or using batteries.
- Battery posts, terminals, and related accessories contain lead components. Wash hands after handling.

An overloaded DC circuit, excessive current draw by the battery, or a wiring problem will automatically trip (turn off) the DC breaker switch. If this happens, wait a few minutes before pressing the breaker switch to the ON position to resume operation. If the breaker switch continues to go OFF, discontinue charging and contact your authorized dealer.

Maintenance

Proper maintenance is important because it will ensure safe, economical and trouble-free operation. It will also reduce air pollution. Improper maintenance may cause the generator to malfunction and can lead to serious injuries.

NOTE

- Shut off the engine before performing any maintenance. When the engine is running, make sure the area is well ventilated.
- If you require a part for replacement, we strongly recommend using Hyundai OEM replacement parts. Do not use non-Hyundai parts. Contact customer service for replacement parts.
- Some of these maintenance techniques can be dangerous and should be performed by a qualified technician.

ITEM	ACTION	EACH USE	1 MONTH (20 HRS)	4 MONTHS (50 HRS)	6 MONTHS (100 HRS)	YEARLY (200 HRS)
Engine Oil	Check Level	●				
	Change		●		●	
Air Filter	Check	●				
	Clean			● REFER TO NOTICE 1		
Spark Plug	Check				●	
	Replace					●
Valve Clearance	Check					● REFER TO NOTICE 2
Combustion Chamber	Clean	EVERY 300 HOURS				
Fuel Tank and Filter	Clean				● REFER TO NOTICE 2	
Fuel Line	Clean	EVERY 2 YEARS (REPLACE IF NECESSARY). REFER TO NOTICE 2.				

NOTICE

1. Service more frequently when used in dusty areas.
2. Should be serviced by an authorized dealer.

Changing the Engine Oil

1. Set the start switch to the STOP position and make sure the fuel cap is fully closed.
2. Loosen the cover screws and remove the maintenance cover.
3. Place a container next to the engine to catch the used oil (refer to fig.).
4. Remove the oil filler cap/dipstick and drain the oil into the container by tilting the generator.
5. With the engine in a level position, add oil to the upper level mark. (refer to fig.).
6. Reinstall the oil filler cap/dipstick securely.
7. Reinstall the maintenance cover and tighten the cover screws securely.

WARNING

- Make sure the start switch is in the STOP position before draining.
- Please dispose of used motor oil in a manner that is compatible with the environment. We suggest you take it in a sealed container to your local service station for reclamation. Do not throw it in the trash or pour it on the ground.
- Do not use gasoline for cleaning since it is flammable and explosive under certain conditions.

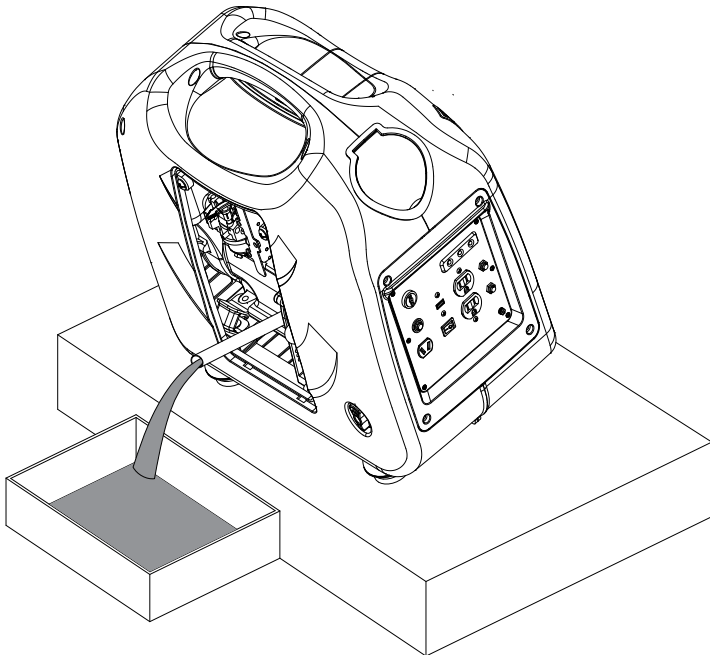

Spark Plug Service

To insure proper operation the spark arrester should be cleaned thoroughly at least once every 100 hours of use.

1. Remove the top screw and the top maintenance cover (refer to fig.).
2. Remove the ignition coil (refer to fig.).
3. Clean any dirt and debris around the spark plug base.
4. Use a wrench to remove the spark plug (refer to fig.).
5. Visually inspect the spark plug. Clean the spark plug with a brush if it is to be reused.
6. The spark plug clearance gap should be between 0.7 mm - 0.8 mm (0.028" to 0.03")
7. Install the correctly gapped spark plug back into the original position.
8. Reinstall the ignition coil securely.
9. Close the top maintenance cover and tighten the screw.

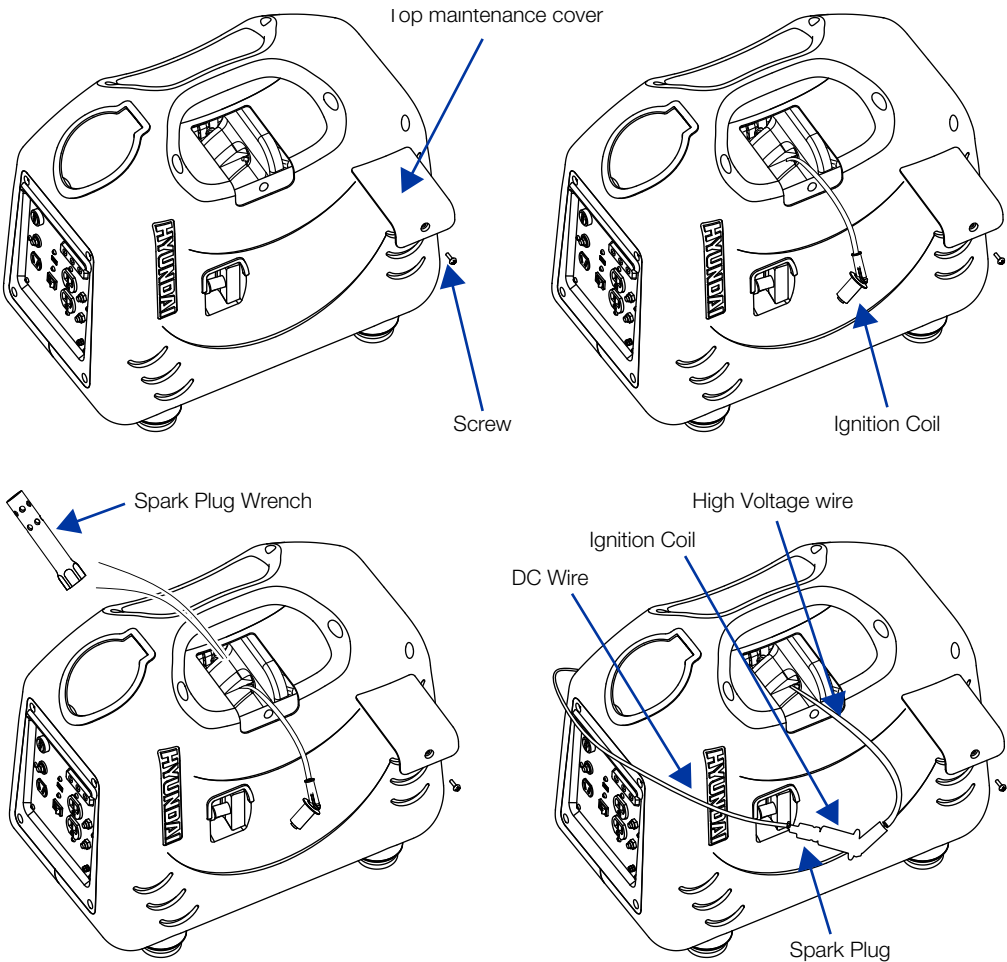

Transportation and Storage

1. Do not overfill the tank.
2. Before attempting to transport allow generator to cool for at least 15 minutes.
3. To prevent fuel spillage, the generator should be secured upright in its normal operating position, with the start switch in the STOP position.
4. Do not drop or strike the generator when transporting.
5. Do not place heavy objects on the generator.

WARNING

- Gasoline is extremely flammable and explosive under certain conditions.
- Do not smoke or allow flames or sparks in the area.

Storage Procedure

DRAIN FUEL

1. remove gas tank cap, remove fuel filter and syphon fuel into an appropriate gasoline container.
2. Rotate fuel valve to the open position and allow any remaining fuel to drain into the pot (refer to fig.).
3. Start the generator and allow fuel remaining in carburetor bowl to be used. Once the generator shuts off it can be stored.

DRAIN OIL

1. Set the start switch to the STOP position and make sure the fuel cap is closed tight.
2. Loosen the cover screws and remove the maintenance cover.
3. Place a container next to the engine to catch the used oil.
4. Remove the oil filler cap/dipstick and drain the oil into the container by tilting the generator.
5. Remove the screw, top maintenance cover and the spark plug.
6. Fill the spark plug orifice with 2cc's (about a tablespoon) of fresh oil. Pull the start motor 3-4 times to distribute the oil.
7. Reinstall the spark plug, top maintenance cover and screw securely.
8. Pull the starter grip slowly until you feel resistance, then return the starter grip gently. This closes the valves so moisture cannot enter.

Troubleshooting

If the generator still does not start, have an authorized Hyundai repair technician diagnose and repair the problem. Attempting service or repair without the proper training, tools and equipment may cause injury to you and/or others. It can also damage the generator or lead to hazardous conditions. For more information please refer to the troubleshoot guide below.

WARNING

- Many troubleshooting procedures present hazards, which can result in severe personal injury or death. Only trained and experienced service personnel with knowledge of fuels, electricity, and machinery hazards should perform service procedures. Review Safety Precautions.
- A hot generator can cause severe burns. Always allow the generator set to cool before performing any maintenance.

PROBLEM	SYMPTOMS	CORRECTION
Generator will not start	Generator will not start	<ol style="list-style-type: none"> 1. The on/off switch is in the “Off” position. Switch to “On.” 2. The engine is out of gasoline. 3. Engine choke is in wrong position. 4. Fouled spark plug, replace with equal or greater quality plug. Refer to page 29 in your user’s guide for a complete list of spark plug compatibility codes. 5. Insufficient oil, add more oil. 6. Clogged fuel line, inspect gas tank for debris.
	High resistance when pulling recoil starter.	<ol style="list-style-type: none"> 1. The engine does not have enough oil - add oil. 2. Air filter element obstructed by debris. Clean according to user guide instructions on page 22.
Difficulty starting	Engine requires many attempts to start	<ol style="list-style-type: none"> 1. Disconnect load before starting. 2. Incorrect oil being used. Please refer to the oil usage chart on page 29 in your user’s guide. 3. Fouled spark plug, replace with equal or greater quality plug. Refer to page 29 in your user’s guide for a complete list of spark plug compatibility codes.
Generator does not produce power	No indicator lights or display on front panel	<ol style="list-style-type: none"> 1. Generator circuit breaker off or tripped 2. Remove all loads, reset breaker, and check device for defects. Do not exceed generator rating.
	Overload indicator light keeps flashing	<ol style="list-style-type: none"> 1. Adjust choke lever. *When a connected device draws high startup power the overload and output indicator light may briefly illuminate, but this is to be expected. Once the device starts up the overload indicator light will shut off and the output light will remain green. 2. Ensure device wattage consumption does not exceed the generator’s maximum peak output.

	No DC output	<ol style="list-style-type: none"> 1. Disconnect battery, reset breaker and test the battery for shorts. 2. Clean battery connector nodes.
Generator outputs unstable power	Connected device does not operate consistently	Verify device start up requirements (Wattage consumption). Do not exceed the generators maximum peak output.
	Device will not start up	<ol style="list-style-type: none"> 1. Remove all loads, reset breaker, and check device for defects. Do not exceed generator rating. 2. Ensure device's wattage consumption does not exceed the generator's maximum peak output.
	Engine idle unusually high or low	Carburetor in need of tuning. For details on how to adjust correctly please contact your local service centre, or contact Midland Intl Inc. at 1-877-528-3772.
Generator overheats	Operation is normal when generator is cool, overheating occurs within moments of start up.	<ol style="list-style-type: none"> 1. Atmospheric temperature high (excess of 35°C). 2. Insufficient air circulation in vicinity of generator. 3. Low oil viscosity, use 10W40 when temperatures exceed 30°C, 10W30 for temperatures between 0° ~ 30°C, and 5W40 for temperatures below 0°C. 4. Fouled spark plug, replace with equal or greater quality plug.
Engine idle fluctuates		<ol style="list-style-type: none"> 1. Carburetor in need of tuning. For details on how to adjust correctly please contact your local service centre, or contact Midland Intl Inc. at 1-877-528-3772. Missing ground reference on return side of differential analog output (external). 2. Air filter element obstructed by debris. Clean according to user guide instructions on page 11.

Engine stops	Engine idles down and shuts off	<ol style="list-style-type: none"> 1. The on/off switch is in the “Off” position. 2. The engine is out of gasoline. Add regular unleaded gasoline. 3. Air filter element obstructed by debris. Clean according to user guide instructions on page 11. 4. Adjust choke lever. 5. Incorrect oil being used or insufficient oil level. Always ensure high oil levels, and use oil according to oil usage chart in user guide on page 31. 6. Fouled spark plug, replace with equal or greater quality plug. Refer to page 29 in your user’s guide for a complete list of spark plug compatibility codes.
Thick smoke released from exhaust	Exhaust fumes thick and dark	<ol style="list-style-type: none"> 1. Adjust choke lever. 2. Incorrect oil being used. Use oil according to oil usage chart in user guide on page 29. 3. Air filter element obstructed by debris. Clean according to user guide instructions on page 11.

Specifications

	HY2000SI	HY2800SEI
WATTS	2200W Peak Power 2000W Running Power	2800W Peak Power 2600W Running Power
AMPS	Output Current 16.6A, Max Circuit 20.0A	Output Current 21.6A, Max Circuit 23.3A
MOTOR	3.8 HP 5500RPM 4-Stroke 125CC Hyundai Motor	5.3HP 5500RPM 4-Stroke 150CC Hyundai Motor
START	Manual Recoil	Manual Recoil and Electric Start
OUTLETS	Two 120V 21.6A AC, One 12V 8.3A DC	Two 120V 21.6A AC, One 12V 8.3A DC, One USB
FUEL CAPACITY	4.5 L	4.5 L
MAX AC OUTPUT	2200W	2800W
FUEL TYPE	Unleaded Gasoline (Mini- mum Octane of 91)	Unleaded Gasoline (Mini- mum Octane of 91)
RUNNING TIME	4.2 hours @75%	3.7 hours @75%
NOISE LEVEL	64dB @7m	65dB @7m
FRAME	33 mm Polypropylene	33 mm Polypropylene
DIMENSIONS	550x310x500 mm	550x310x500 mm
WEIGHT	32 kg	35 kg

RECOMMENDED OIL USAGE

OIL GRADE	TEMPERATURE	SEASON
5W40	0° & below	Winter
10W40	20° to -5°	Spring/Fall
15W40	20°+	Summer
10W30	25° to -15	All season

SPARK PLUG COMPATIBILITY

BRAND	HY2000SI	HY2800SEI
NGK	CR7HS	CR7HS
DENSO	U20FPR	U20FPR
CHAMPION	RZ10YC	RZ10YC
BOSCH	U24BC	U24BC

Glossary

AC SOCKET - The receptacle for the device plug used for AC application.

AC CIRCUIT PROTECTOR - It protects AC circuits from being damaged due to overload or short circuit by stopping the flow of electricity between the generator and device.

AIR FILTER - It removes dust from engine intake air.

CARBURETOR - A device used to properly mix fuel and air in the correct proportions and deliver the mixture into the engine's combustion chamber.

CHOKE ROCKER - It is used to provide proper starting mixture when the engine is cold. The choke lever must be pulled out to ON position when starting a cold engine.

DC BREAKER SWITCH - It protects DC circuits from being damaged due to overload or short circuit by stopping the flow of electricity between the generator and device.

DC SOCKET - The receptacle used for charging a 12 V battery

DIPSTICK - It seals off engine oil fill hole and is used for indicating the engine oil level.

DRAIN PLUG - A plug that can be removed to allow the fluid contents of the engine to be drained off.

ECON SWITCH - This system can be described as a load-dependent speed control-type governor that offers excellent fuel economy by automatically adjusting engine speed to the optimum level, given the usage load. This not only reduces fuel consumption and operating noise in the normal usage range, but it also keeps exhaust emissions to levels low enough to clear some of the strictest CARB and EPA emission standards.

FUEL SWITCH - It controls flow of fuel from fuel tank to carburetor.

GROUND TERMINAL - It connects generator to ground wire for grounding protection.

OIL INDICATOR LIGHT - Before the oil level falls below a safe limit, the Oil Indicator light (red) will go ON and the Oil Alert system will automatically stop the engine.

OUTPUT INDICATOR LIGHT - The output indicator light (green) is illuminated when the generator is operating normally. It indicates that the generator is producing power at the receptacles

OVERLOAD INDICATOR LIGHT - If the generator is overloaded, or if there is a short circuit in a connected device, the overload indicator light (red) will go ON. It will stay ON, and after about four seconds, the device will shut off and the output indicator light (green) will go OFF.

RECOIL STARTER - A pull cord is attached to the engine and you pull the T-handle attached to the starter cord assembly to spin the fly-wheel and start the engine.

SPARK PLUG - A device inserted in the head of an internal-combustion engine cylinder, which ignites the fuel mixture by means of an electric spark.

Chapter 9 - Learn About your Warranty

Toll Free: 1-877-528-3772

E-mail: support@hyundaipower.ca

Online: www.hyundaipower.ca

HYUNDAI POWER EQUIPMENT PRODUCTS ARE DISTRIBUTED BY:

Midland Power Inc.

376 Magnetic Drive, Toronto, ON M3J 2C4, Canada

This product is warranted to be free of defects in material and workmanship for two years from date of purchase. This warranty guarantees that any defective parts will be repaired or replaced at no cost, including diagnosis and replacement parts.

LIMITED WARRANTY PERIODS

Recreational and Residential use: Two Years Limited

- 1st Year: Parts and Labor
- 2nd Year: Parts only

Commercial use: 6 months limited, parts and labor

This limited warranty begins at the initial time of retail purchase and covers manufacturer's defects caused by a defect in components or workmanship during the two (2) Year period. The warranty coverage is continual from the initial date of purchase and does not restart at anytime under any circumstances. This limited warranty is valid for residential or recreational applications only and only when the generator receives all necessary preventative maintenance as described in the Hyundai Generators User Guide. The repair or replacement of a generator will take place within a reasonable period of time during normal business hours. All repair and replacement parts shall be warranted for (90) days after the initial date of installation or purchase.

LIMITATION OF REMEDIES AND DISCLAIMERS

Midland International Inc. disclaims any responsibility for loss of time or use of the generator in a recreational vehicle or any vehicle in which the generator is installed, transportation, commercial loss, or any other incidental or consequential damage.

Any implied warranties are limited to the duration of this written warranty. **THE FOREGOING LIMITED WARRANTY IS EXCLUSIVE OF AND IN LIEU OF ALL OTHER WARRANTIES OF MERCHANTABILITY, FITNESS FOR A PARTICULAR PURPOSE AND OF ANY OTHER WARRANTY WHETHER EXPRESS OR IMPLIED.** Consumable parts, such as oil or fuel filters, fuel cut off valve, brushes, fuel

injection nozzle valve, lubricant, or ignition plug, are not covered under this warranty. All expenses incurred in maintaining and replacing parts for generator shall fall on the purchaser. This warranty coverage does not include parts affected by accident and/or collision, corrosion or rust, normal wear, incorrect fuel type or fuel contamination, use in an application for which the product was not intended, unauthorized service, or any other misuse, neglect, incorporation or use of unsuitable attachments or parts. Damage to voltage regulators caused by failure to ground, shorting or overloading will not be covered under this warranty. Under this Warranty, we do not have the obligation to bear any transportation fees of any product to/from an authorized Warranty Center. Unauthorized alteration, installation or any cause other than defects in material or workmanship of the product will not be covered under the warranty.

EXCLUSIONS NOT COVERED BY THIS LIMITED WARRANTY

1. Normal engine/alternator wear
2. Damage caused by lack of maintenance as described in the Hyundai User Guides, or negligence by using improper or impure motor oil, coolant, or fuel
3. Damage caused by accidents, improper installation or storage;
4. Damage caused by water ingestion, submersion, or external water damage
5. Damage or non-performance caused by operation of the generator set in a marine application
6. Damage caused by operation with improper fuel, or at speeds, loads, conditions, or modifications contrary to published specifications.
7. Items not supplied by Hyundai, including, but not limited to, starting batteries, battery cables, external wiring, fuel lines, filters, etc;(refer to exclusions)
8. Repairs made during the warranty period, without first obtaining a case number from Hyundai

Batteries supplied with any generator product should be considered a bonus item and not covered by warranty. Batteries can be damaged by shock, shorting terminals, heat, acid spillage and a number of other factors that cannot be controlled after they have left our facility. It is the customer's responsibility to take great care when handling a battery so no spillage of acid will occur and cause corrosion; damage caused by battery acid is not covered under this warranty.

Warranty Claim Procedure:

Warranty service must be performed by one of our authorized service dealers. If you feel your generator is malfunctioning due to a defect or misuse, simply contact our customer support center for technical advice, a warranty claim or general information.

Warranty service, operation assistance and product support is provided by Midland Power Inc., contact us at the following numbers.

PRODUCT REGISTRATION

Product registration is required for product support and warranty coverage. The owner's registration found in the user guide can be completed and mailed. **You can also register online at www.hyundaipower.ca.** Once your registration is complete, your receipt will be on file and any future warranty claims will be easily created.

Proof of purchase may be required for warranty claims. Keep a copy of the original receipt, UPC code and serial number with this user guide.

CUSTOMER SERVICE

1-877-528-3772 (toll-free)

www.hyundaipower.ca

OUR WARRANTY RIGHTS AND OBLIGATIONS:

CALIFORNIA: The California Air Resources Board and Midland Power Inc. are pleased to explain the emission control system warranty on your Midland Power Inc. engine. In California, new spark-ignited small off-road equipment engines must be designed, built, and equipped to meet the State's stringent anti-smog standards.

OTHER STATES, U.S. TERRITORIES, AND CANADA: In other areas of the United States and in Canada, your engine must be designed, built, and equipped to meet the U.S. EPA and Environment Canada emission standards for spark-ignited engines at or below 19 kilowatts.

ALL OF THE UNITED STATES AND CANADA: Midland Power Inc. must warrant the emission control system on your power equipment engine for the period of time listed, provided there has been no abuse, neglect, or improper maintenance of your power equipment engine. Where a warrantable condition exists, Midland Power Inc. will repair your power equipment engine at no cost to you including diagnosis, parts, and labor. Your emission control system may include such parts as the carburetor or fuel injection system, the ignition system, and catalytic converter. Also included may be hoses, connectors, and other emission-related assemblies.

Enjoy!

Be sure to check www.hyundaipower.ca for updates regarding your generator.

Free Manuals Download Website

<http://myh66.com>

<http://usermanuals.us>

<http://www.somanuals.com>

<http://www.4manuals.cc>

<http://www.manual-lib.com>

<http://www.404manual.com>

<http://www.luxmanual.com>

<http://aubethermostatmanual.com>

Golf course search by state

<http://golfingnear.com>

Email search by domain

<http://emailbydomain.com>

Auto manuals search

<http://auto.somanuals.com>

TV manuals search

<http://tv.somanuals.com>