

**brother**<sup>®</sup>

# Basic User's Guide

## DCP-8110DN

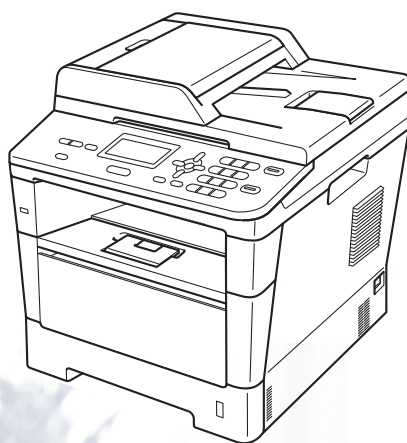

Version 0

UK/IRE

## **If you need to call Customer Service**

**Please complete the following information for future reference:**

**Model Number: DCP-8110DN**  
**(Circle your model number)**

**Serial Number:** <sup>1</sup> \_\_\_\_\_

**Date of Purchase:** \_\_\_\_\_

**Place of Purchase:** \_\_\_\_\_

**<sup>1</sup> The serial number is on the back of the unit. Retain this User's Guide with your sales receipt as a permanent record of your purchase, in the event of theft, fire or warranty service.**

**Register your product on-line at**

**<http://www.brother.com/registration/>**

# User's Guides and where do I find them?

| Which Guide?   | What's in it?   | Where is it?                                     |
|--|---|--|
| <b>Product Safety Guide</b>                                | Read this Guide first. Please read the Safety Instructions before you set up your machine. See this Guide for trademarks and legal limitations.   | Printed / In the box                             |
| <b>Quick Setup Guide</b>                                   | Follow the instructions for setting up your machine and installing the drivers and software for the operating system and connection type you are using.   | Printed / In the box                             |
| <b>Basic User's Guide</b>                                  | Learn the basic Copy, Scan and Direct Print operations and how to replace consumables. See troubleshooting tips.  | PDF file / Installer CD-ROM / In the box         |
| <b>Advanced User's Guide</b>                               | Learn more advanced operations: Copy, security features, printing reports and performing routine maintenance.   | PDF file / Installer CD-ROM / In the box         |
| <b>Software User's Guide</b>                               | Follow these instructions for Printing, Scanning, Network Scanning and using the Brother ControlCenter utility.   | PDF file / Installer CD-ROM / In the box         |
| <b>Network User's Guide</b>                                | This Guide provides useful information about wired network settings and security settings using the Brother machine. You can also find supported protocol information for your machine and detailed troubleshooting tips.                                     | PDF file / Installer CD-ROM / In the box         |
| <b>Google Cloud Print Guide</b>                            | This Guide provides details on how to configure your Brother machine to a Google account and use Google Cloud Print services for printing over the Internet from devices using Gmail™ for mobile, GOOGLE DOCS™ for mobile and applications for the Chrome OS. | PDF file / Brother Solutions Center <sup>2</sup> |
| <b>Mobile Print/Scan Guide for Brother iPrint&amp;Scan</b> | This Guide provides useful information about printing JPEG and PDF <sup>1</sup> files from your mobile device and scanning from your Brother machine to your mobile device when connected on a Wi-Fi network.   | PDF file / Brother Solutions Center <sup>2</sup> |

<sup>1</sup> PDF printing is not supported on Windows® Phone.

<sup>2</sup> Visit us at <http://solutions.brother.com/>.

# Table of Contents

## (Basic User's Guide)

|          |  |           |
|----------|--|-----------|
| <b>1</b> | <b>General information</b>   | <b>1</b>  |
|          | Using the documentation .....  | 1         |
|          | Symbols and conventions used in the documentation .....                                      | 1         |
|          | Accessing the Advanced User's Guide, Software User's Guide<br>and Network User's Guide ..... | 2         |
|          | Viewing Documentation .....  | 2         |
|          | How to access the User's Guides for Advanced Features .....                                  | 4         |
|          | Accessing Brother Support (Windows®) .....   | 4         |
|          | Accessing Brother Support (Macintosh) .....  | 5         |
|          | Control panel overview .....   | 6         |
|          | Data LED indications .....   | 8         |
|          | Volume settings .....  | 9         |
|          | Beeper volume .....  | 9         |
| <b>2</b> | <b>Loading paper</b>   | <b>10</b> |
|          | Loading paper and print media .....  | 10        |
|          | Loading paper in the standard paper tray and the optional lower tray .....                   | 10        |
|          | Loading paper in the multi-purpose tray (MP tray) .....                                      | 12        |
|          | Unscannable and unprintable areas .....  | 16        |
|          | Paper settings .....   | 17        |
|          | Paper Type .....   | 17        |
|          | Paper Size .....   | 17        |
|          | Tray Use in COPY mode .....  | 18        |
|          | Tray Use in print mode .....   | 18        |
|          | Acceptable paper and other print media .....   | 19        |
|          | Recommended paper and print media .....  | 19        |
|          | Type and size of paper .....   | 19        |
|          | Handling and using special paper .....   | 21        |
| <b>3</b> | <b>Loading documents</b>   | <b>24</b> |
|          | How to load documents .....  | 24        |
|          | Using the automatic document feeder (ADF) .....  | 24        |
|          | Using the scanner glass .....  | 25        |
| <b>4</b> | <b>Making copies</b>   | <b>26</b> |
|          | How to copy .....  | 26        |
|          | Stop copying .....   | 26        |
|          | Copy settings .....  | 26        |

|          |  |           |
|----------|--|-----------|
| <b>5</b> | <b>Printing data from a USB Flash memory drive or digital camera supporting mass storage</b>           | <b>27</b> |
|          | Creating a PRN file for direct printing .....  | 27        |
|          | Printing data directly from the USB Flash memory drive or digital camera supporting mass storage ..... | 28        |
| <b>6</b> | <b>How to print from a computer</b>  | <b>31</b> |
|          | Printing a document.....   | 31        |
| <b>7</b> | <b>How to scan to a computer</b>   | <b>32</b> |
|          | Scanning a document as a PDF file using ControlCenter4 (Windows®) .....                                | 32        |
|          | Changing the SCAN key settings .....   | 35        |
|          | Before scanning.....   | 35        |
|          | SCAN key settings.....   | 35        |
|          | Scanning using the SCAN key .....  | 37        |
| <b>A</b> | <b>Routine maintenance</b>   | <b>38</b> |
|          | Replacing the consumable items.....  | 38        |
|          | Replacing the toner cartridge .....  | 40        |
|          | Replacing the drum unit.....   | 46        |
|          | Cleaning and Checking the machine.....   | 51        |
|          | Cleaning the outside of the machine .....  | 51        |
|          | Cleaning the scanner glass .....   | 52        |
|          | Cleaning the corona wire .....   | 53        |
|          | Cleaning the drum unit .....   | 55        |
|          | Cleaning the paper pick-up rollers.....  | 59        |

|          |  |            |
|----------|--|------------|
| <b>B</b> | <b>Troubleshooting</b>                               | <b>61</b>  |
|          | Identifying your problem .....                       | 61         |
|          | Error and maintenance messages .....                 | 62         |
|          | Document Jams .....                                  | 68         |
|          | Document is jammed in the top of the ADF unit .....  | 68         |
|          | Document is jammed under the document cover .....    | 68         |
|          | Removing small documents jammed in the ADF .....     | 69         |
|          | Document is jammed at the output tray .....          | 69         |
|          | Paper Jams .....                                     | 70         |
|          | Paper is jammed in the MP tray .....                 | 70         |
|          | Paper is jammed in paper tray 1 or tray 2 .....      | 71         |
|          | Paper is jammed at the back of the machine .....     | 72         |
|          | Paper is jammed inside the machine .....             | 75         |
|          | Paper is jammed in the duplex tray .....             | 79         |
|          | If you are having difficulty with your machine ..... | 81         |
|          | Improving the print quality .....                    | 87         |
|          | Machine Information .....                            | 94         |
|          | Checking the Serial Number .....                     | 94         |
|          | Reset functions .....                                | 94         |
|          | How to reset the machine .....                       | 94         |
| <b>C</b> | <b>Menu and features</b>                             | <b>95</b>  |
|          | On-screen programming .....                          | 95         |
|          | How to access the menu mode .....                    | 95         |
|          | Menu table .....                                     | 96         |
|          | Entering text .....                                  | 108        |
| <b>D</b> | <b>Specifications</b>                                | <b>110</b> |
|          | General .....  | 110        |
|          | Document Size .....                                  | 112        |
|          | Print media .....                                    | 113        |
|          | Copy .....   | 114        |
|          | Scanner .....  | 115        |
|          | Printer .....  | 116        |
|          | Direct Print feature .....                           | 117        |
|          | Computer requirements .....                          | 118        |
|          | Consumable items .....                               | 120        |
|          | Interfaces .....                                     | 121        |
|          | Network (LAN) .....                                  | 122        |
| <b>E</b> | <b>Index</b>   | <b>123</b> |

# Table of Contents

## (Advanced User's Guide)

You can view the Advanced User's Guide on the Installer CD-ROM.

The Advanced User's Guide explains the following features and operations.

### **1 General Setup**

---

*Memory storage*

*Automatic Daylight Saving Time*

*Ecology features*

*Quiet mode feature*

*LCD Contrast*

*Glass ScanSize*

*User Settings List*

*Network Configuration Report*

### **2 Security features**

---

*Secure Function Lock 2.0*

*Setting Lock*

### **3 Making copies**

---

*Copy settings*

*Duplex (2-sided) copying*

### **A Routine maintenance**

---

*Cleaning and checking the machine*

*Replacing periodic maintenance parts*

*Packing and shipping the machine*

### **B Options**

---

*Optional paper tray (LT-5400)*

*Memory board*

### **C Glossary**

---

### **D Index**

---





## Using the documentation

Thank you for buying a Brother machine! Reading the documentation will help you make the most of your machine.

## Symbols and conventions used in the documentation

The following symbols and conventions are used throughout the documentation.

### WARNING

WARNING indicates a potentially hazardous situation which, if not avoided, could result in death or serious injuries.

### Important

Important indicates a potentially hazardous situation which, if not avoided, may result in damage to property or loss of product functionality.



Prohibition icons indicate actions that must not be performed.



Electrical Hazard icons alert you to a possible electrical shock.



Fire Hazard icons alert you to the possibility of fire.



Hot Surface icons warn you not to touch machine parts that are hot.



Notes tell you how you should respond to a situation that may arise or give tips about how the current operation works with other features.

**Bold** Bold style identifies keys on the machine's control panel or on the computer screen.

*Italics* Italicized style emphasizes an important point or refers you to a related topic.

`Courier New` Courier New font identifies the messages shown on the LCD of the machine.

Follow all warnings and instructions marked on the product.

# Accessing the Advanced User's Guide, Software User's Guide and Network User's Guide

This Basic User's Guide does not contain all the information about the machine such as how to use the advanced features for Copy, Printer, Scanner and Network. When you are ready to learn detailed information about these operations, read the **Advanced User's Guide**, **Software User's Guide** and **Network User's Guide** that are on the Installer CD-ROM.

## Viewing Documentation

### Viewing Documentation (Windows®)

To view the documentation, from the **Start** menu, select **Brother, DCP-XXXX** (where XXXX is your model name) from the programs list, and then choose **User's Guides**.

If you have not installed the software, you can find the documentation on the Installer CD-ROM by following the instructions below:

- 1 Turn on your computer. Insert the Installer CD-ROM into your CD-ROM drive.



### Note

If the Brother screen does not appear automatically, go to **My Computer (Computer)**, double-click the CD-ROM icon, and then double-click **start.exe**.

- 2 If the model name screen appears, click your model name.

- 3 If the language screen appears, click your language. The CD-ROM Top Menu will appear.

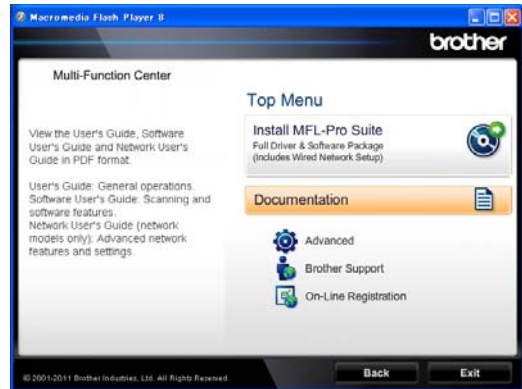

- 4 Click **Documentation**.
- 5 Click **PDF documents**. If the country screen appears, choose your country. After the list of User's Guides appears, choose the Guide you want to read.

### Viewing Documentation (Macintosh)

- 1 Turn on your Macintosh. Insert the Installer CD-ROM into your CD-ROM drive. The following window will appear.



- 2 Double-click the **Documentation** icon.
- 3 If the model name screen appears, choose your model name and click **Next**.
- 4 If the language screen appears, double-click your language folder.

- 5 Double-click **top.pdf**. If the country screen appears, choose your country.
- 6 After the list of User's Guides appears, choose the Guide you want to read.

### How to find Scanning instructions

There are several ways you can scan documents. You can find the instructions as follows:

#### Software User's Guide

- *Scanning*
- *ControlCenter*
- *Network Scanning*

#### Nuance™ PaperPort™ 12SE How-to-Guides

##### (Windows® users)

- The complete Nuance™ PaperPort™ 12SE How-to- Guides can be viewed from the Help section in the Nuance™ PaperPort™ 12SE application.

### Presto! PageManager User's Guide (Macintosh users)



#### Note

Presto! PageManager must be downloaded and installed before use. For further instructions, see *Accessing Brother Support (Macintosh)* >> page 5.

- The complete Presto! PageManager User's Guide can be viewed from the Help section in the Presto! PageManager application.

### How to find Network setup instructions

Your machine can be connected to a wired network.

Basic setup instructions >> Quick Setup Guide

For more information about network setup >> Network User's Guide

## How to access the User's Guides for Advanced Features

You can view and download these Guides from the Brother Solutions Center at:

<http://solutions.brother.com/>

### Google Cloud Print Guide

This Guide provides details on how to configure your Brother machine to a Google account and use Google Cloud Print services for printing over the Internet from devices using Gmail™ for mobile, GOOGLE DOCS™ for mobile and applications for the Chrome OS.

### Mobile Print/Scan Guide for Brother iPrint&Scan

This Guide provides useful information about printing JPEG and PDF <sup>1</sup> files from your mobile device and scanning from your Brother machine to your mobile device when connected on a Wi-Fi network.

<sup>1</sup> PDF printing is not supported on Windows® Phone.

## Accessing Brother Support (Windows®)

You can find all the links you will need, such as Web support (Brother Solutions Center) on the Installer CD-ROM.

- Click **Brother Support** on the main menu. The following screen will appear:



- To access our website (<http://www.brother.com/>), click **Brother Home Page**.
- For the latest news and product support information (<http://solutions.brother.com/>), click **Brother Solutions Center**.
- To visit our website for original Brother Supplies (<http://www.brother.com/original/>), click **Supplies Information**.
- To access the Brother CreativeCenter (<http://www.brother.com/creativecenter/>) for FREE photo projects and printable downloads, click **Brother CreativeCenter**.
- To return to the main page, click **Back** or if you have finished, click **Exit**.

# Accessing Brother Support (Macintosh)

You can find all the links you will need, such as Web support (Brother Solutions Center) on the Installer CD-ROM.

- Double-click the **Brother Support** icon. The following screen will appear:



- To download and install Presto! PageManager, click **Presto! PageManager**.
- To register your machine using the Brother Product Registration Page (<http://www.brother.com/registration/>), click **On-Line Registration**.
- For the latest news and product support information (<http://solutions.brother.com/>), click **Brother Solutions Center**.
- To visit our website for original Brother Supplies (<http://www.brother.com/original/>), click **Supplies Information**.

# Control panel overview

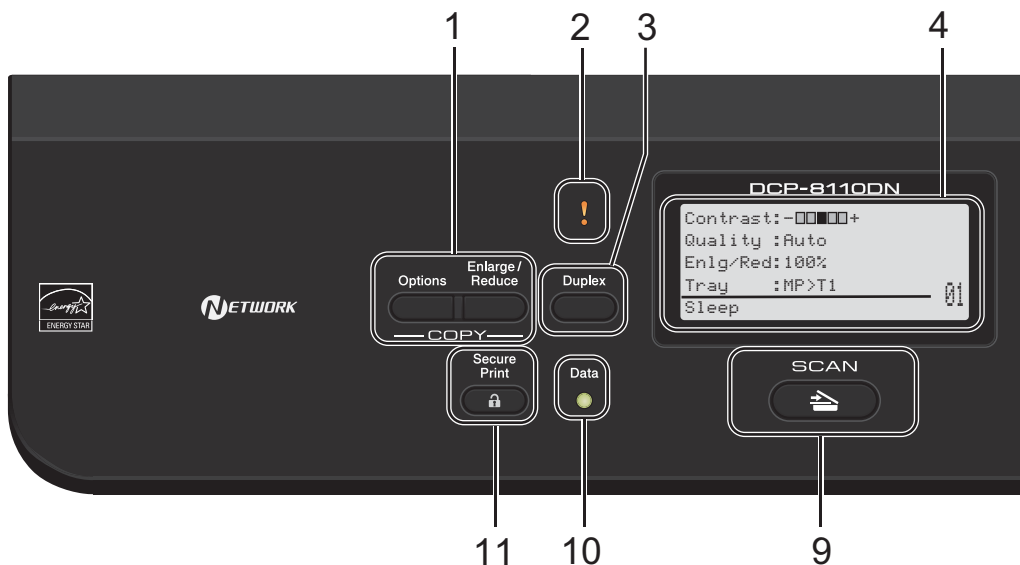

## 1 COPY keys:

### Options

You can quickly and easily choose temporary settings for copying.

### Enlarge/Reduce

Enlarges or reduces copies.

## 2 Error LED

Blinks in orange when the LCD displays an error or an important status message.

## 3 Duplex

You can choose Duplex to copy or print on both sides of the paper.

## 4 LCD

Displays messages to help you set up and use your machine.

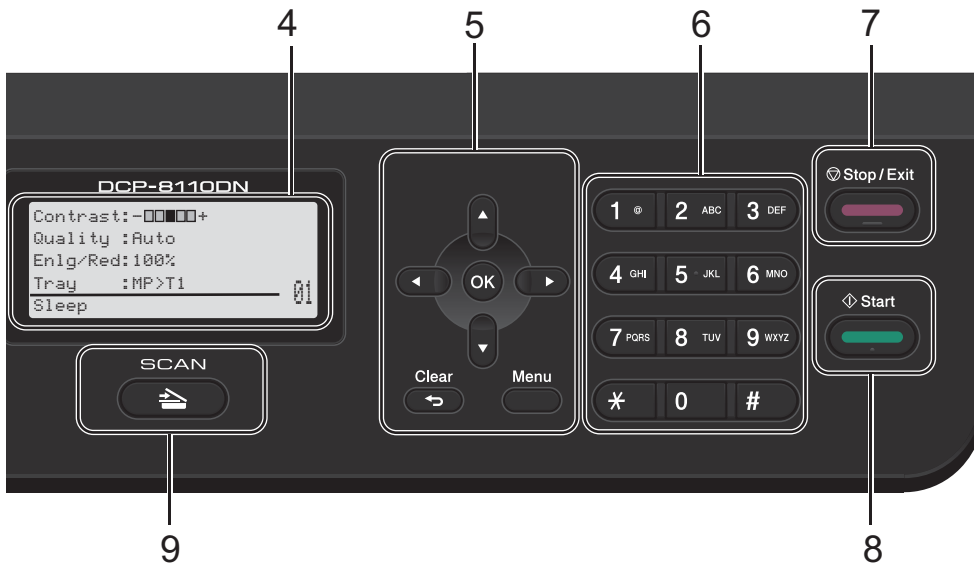

## 5 Menu keys:

### Clear

Deletes entered data or lets you cancel the current setting.

### Menu

Lets you access the Menu to program your settings or retrieve information from the machine.

### OK

Lets you store your settings and confirm LCD messages.

### Selection keys:

◀ or ▶

Press to scroll backwards or forwards through menu selections.

▲ or ▼

Press to scroll through the menus and options.

## 6 Numeric keys

Use these keys to enter text.

## 7 Stop/Exit

Stops an operation or exits from a menu.

## 8 Start

Lets you start making copies.

## 9 SCAN:



**SCAN**

Puts the machine in SCAN mode.

## 10 Data LED

The LED will flash depending on the machine's status.

## 11 Secure Print



You can print data saved in the memory when you enter your four-digit password. (▶▶ Software User's Guide)

When using Secure Function Lock, you can switch restricted users by holding down ◀ as you press **Secure Print**. (▶▶ Advanced User's Guide: *Secure Function Lock 2.0*)

## Data LED indications

The **Data** LED (light emitting diode) will flash depending on the machine's status.



| LED  | Machine's Status         | Description  |
|--|--------------------------|--|
|                         | Ready Mode               | The machine is ready to print, in Sleep mode, there is no print data, or the power switch is off.    |
| <br>Green<br>(blinking) | Receiving Data           | The machine is either receiving data from the computer, processing data in memory, or printing data. |
| <br>Green               | Data Remaining in Memory | Print data remains in the machine's memory.  |



# Volume settings

## Beeper volume

---

When the beeper is on, the machine will beep when you press a key or make a mistake. You can choose a range of volume levels.

- 1 Press **Menu**, **1**, **2**.
- 2 Press **▲** or **▼** to choose **Low**, **Med**, **High** or **Off**.  
Press **OK**.
- 3 Press **Stop/Exit**.

# 2

## Loading paper

### Loading paper and print media

The machine can feed paper from the standard paper tray, optional lower tray or multi-purpose tray.



#### Note

If your application software supports paper size selection in the print menu, you can select it through the software. If your application software does not support it, you can set the paper size in the printer driver or by using the control panel buttons.

### Loading paper in the standard paper tray and the optional lower tray

You can load up to 250 sheets in the standard paper tray (Tray 1) and 500 sheets in the optional lower tray (Tray 2). Paper can be loaded up to the maximum paper mark (▼▼▼) on the right-hand side of the paper tray. (For recommended paper to use, see *Acceptable paper and other print media* >> page 19.)

### Printing on plain paper, thin paper or recycled paper from Tray 1 and Tray 2

- 1 Pull the paper tray completely out of the machine.

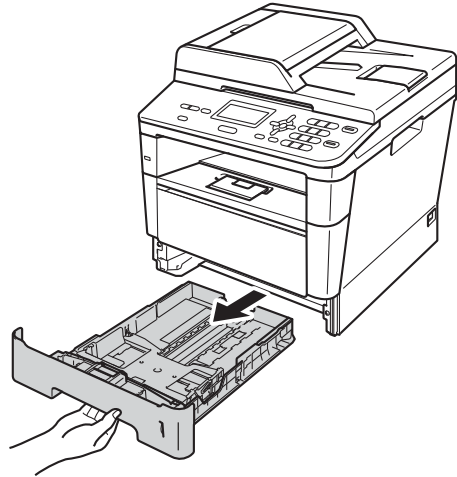

- 2 While pressing the green paper-guide release lever (1), slide the paper guides to fit the paper you are loading in the tray. Make sure that the guides are firmly in the slots.

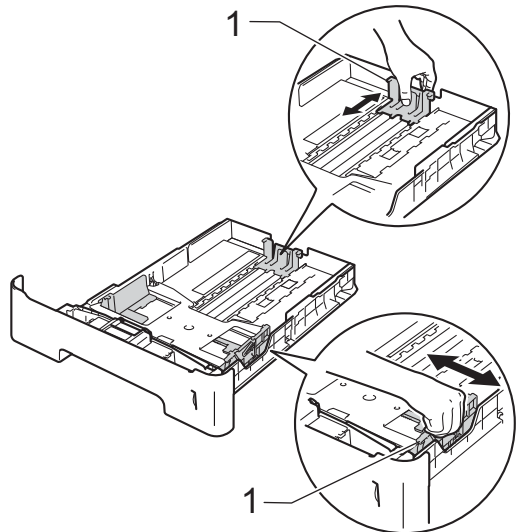

- 3 Fan the stack of paper well to avoid paper jams and misfeeds.

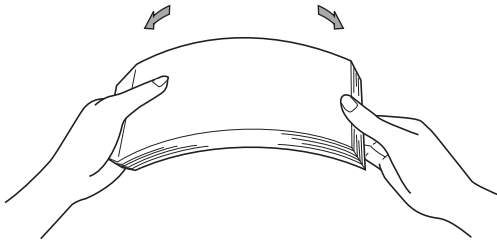

- 4 Put paper in the tray and make sure:

- The paper is below the maximum paper mark (▼▼▼) (1).  
Overfilling the paper tray will cause paper jams.
- The side to be printed on must be *face down*.
- The paper guides touch the sides of the paper so it will feed correctly.

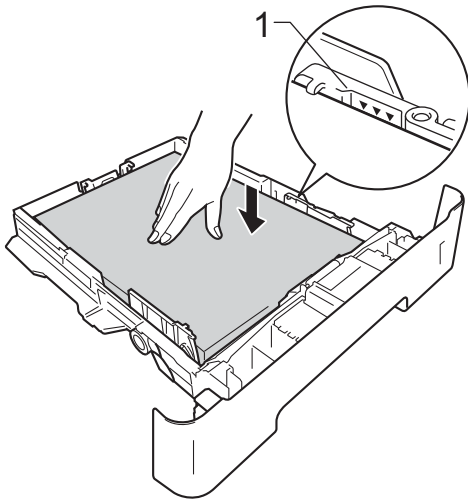

- 5 Put the paper tray firmly back in the machine. Make sure that it is completely inserted into the machine.

- 6 Lift up the support flap (1) to prevent paper from sliding off the face-down output tray, or remove each page as soon as it comes out of the machine.

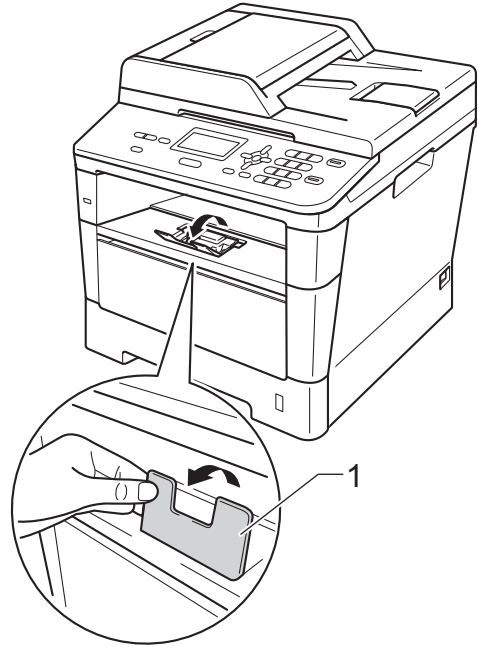

## Loading paper in the multi-purpose tray (MP tray)

You can load up to 3 envelopes or special print media in the MP tray or up to 50 sheets of plain paper. Use this tray to print or copy on thick paper, bond paper, labels or envelopes. (For recommended paper to use, see *Paper capacity of the paper trays* >> page 20.)

### Printing on plain paper, thin paper, recycled paper and bond paper from the MP tray

- 1 Open the MP tray and lower it gently.

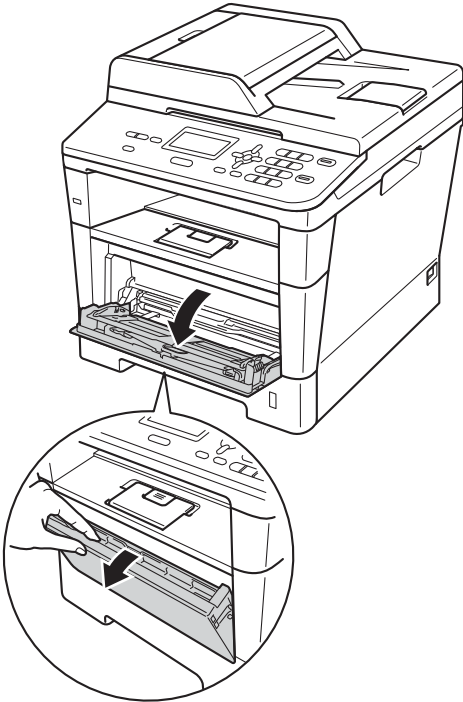

- 2 Pull out the MP tray support (1) and unfold the flap (2).

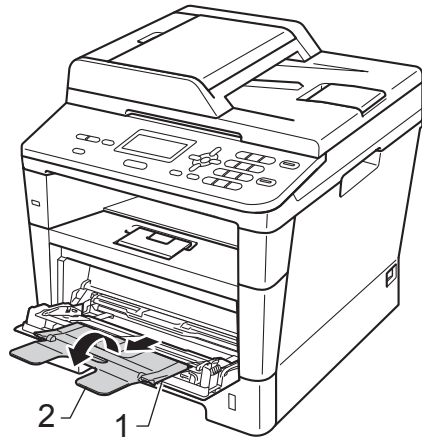

- 3 Put paper in the MP tray and make sure:
- The paper stays under the maximum paper mark (1).
  - The side to be printed on must be *face up* with the leading edge (top of the paper) in first.
  - The paper guides must gently touch the sides of the paper so it will feed correctly.

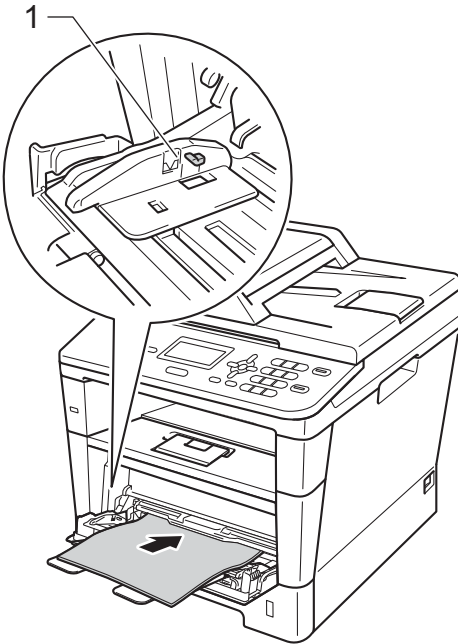

- 4 Lift up the support flap to prevent paper from sliding off the face-down output tray, or remove each page as soon as it comes out of the machine.

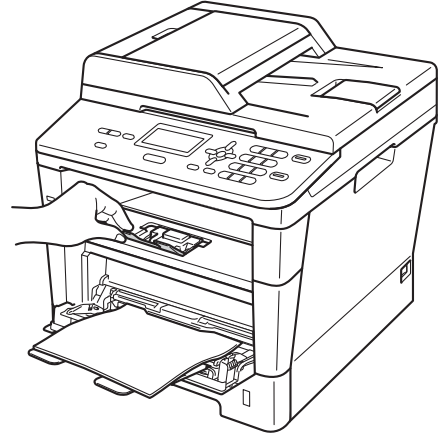

## Printing on thick paper, labels and envelopes from the MP tray

Before loading, press the corners and sides of the envelopes to make them as flat as possible.

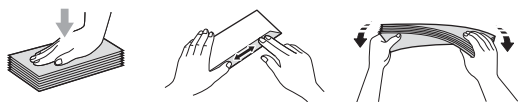

- 1 Open the back cover (face-up output tray).

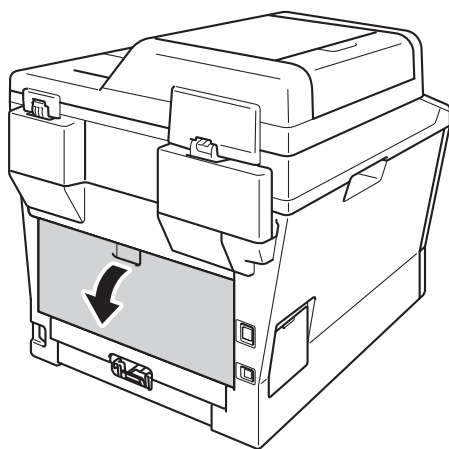

- 2 Open the MP tray and lower it gently.

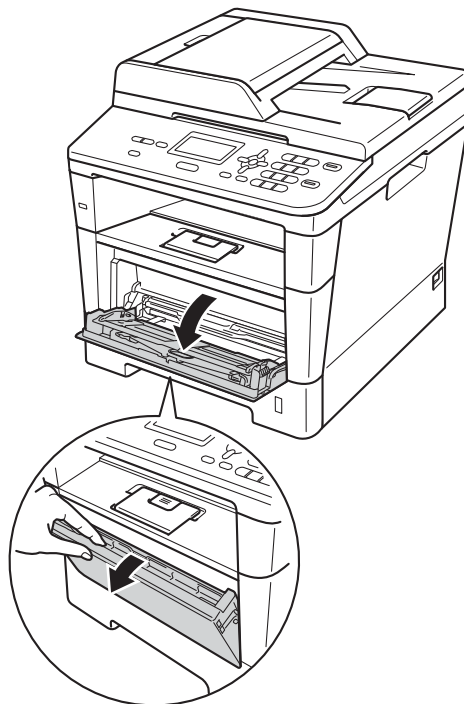

- 3 Pull out the MP tray support (1) and unfold the flap (2).

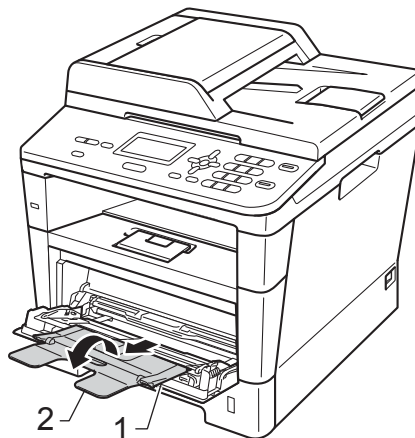

4 Put paper, labels or envelopes in the MP tray. Make sure:

- The number of envelopes in the MP tray does not exceed 3.
- The paper, labels or envelopes stay under the maximum paper mark (1).
- The side to be printed on is face up.



5 Send the print data to the machine.

**Note**

- Remove each printed envelope immediately to prevent a paper jam.
- If your thick paper curls during printing, put only one sheet at a time in the MP tray and open the back cover (face-up output tray) to let the printed pages exit to the face-up output tray.

6 Close the back cover (face-up output tray).

## Unscannable and unprintable areas

The figures below show maximum unscannable and unprintable areas. These areas may vary depending on the paper size or settings in the application you are using.



### Note

When using BR-Script3 emulation, the unprintable area around the edges of the paper is 4.2 mm.

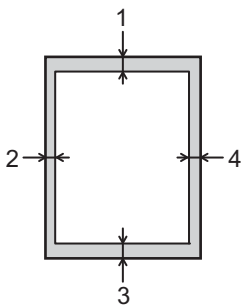

| Usage  | Document Size | Top (1)<br>Bottom (3) | Left (2)<br>Right (4) |
|--|---------------|-----------------------|-----------------------|
| Copy*<br><br>* a single copy<br>or a 1 in 1 copy | Letter        | 4 mm                  | 4 mm                  |
|  | A4            | 4 mm                  | 3 mm                  |
|  | Legal         | 4 mm                  | 4 mm                  |
| Scan   | Letter        | 3 mm                  | 3 mm                  |
|  | A4            | 3 mm                  | 3 mm                  |
|  | Legal         | 3 mm                  | 3 mm                  |
| Print  | Letter        | 4.2 mm                | 6.35 mm               |
|  | A4            | 4.2 mm                | 6.01 mm               |
|  | Legal         | 4.2 mm                | 6.35 mm               |



## Paper settings

### Paper Type

Set up the machine for the type of paper you are using. This will give you the best print quality.

- 1 Do one of the following:
    - To set the paper type for the MP Tray press **Menu, 1, 1, 1, 1**.
    - To set the paper type for Tray#1 press **Menu, 1, 1, 1, 2**.
    - To set the paper type for Tray#2<sup>1</sup> press **Menu, 1, 1, 1, 3**.
  - 2 Press ▲ or ▼ to choose Thin, Plain, Thick, Thicker, Recycled Paper or Label<sup>2</sup>. Press **OK**.
  - 3 Press **Stop/Exit**.
- <sup>1</sup> Tray#2 appears only if the optional lower tray is installed.
- <sup>2</sup> The Label type option appears only if you chose the MP tray in step 1.

### Paper Size

You can use the following sizes of paper.

For Copies:

A4, Letter, Legal, Executive, A5, A5 L, A6, B5, B6 and Folio

When you change the size of paper in the tray, you will also need to change the Paper Size setting so your machine can fit the document on the page.

- 1 Do one of the following:
    - To set the paper size for the MP Tray press **Menu, 1, 1, 2, 1**.
    - To set the paper size for Tray#1 press **Menu, 1, 1, 2, 2**.
    - To set the paper size for Tray#2<sup>1</sup> press **Menu, 1, 1, 2, 3**.
  - 2 Press ▲ or ▼ to choose A4, Letter, Legal, Executive, A5, A5 L, A6, B5, B6, Folio or Any<sup>2</sup>. Press **OK**.
  - 3 Press **Stop/Exit**.
- <sup>1</sup> Tray#2 appears only if the optional lower tray is installed.
- <sup>2</sup> The Any option appears only when you choose the MP tray.



#### Note

- If you choose Any for the MP Tray Paper Size, you must choose MP Only for the Tray Use setting. You cannot use the Any Paper Size option for the MP tray when making N in 1 copies. You must choose one of the other available Paper Size options for the MP tray.
- A5 L and A6 size are not available for Tray#2.

## Tray Use in COPY mode

You can change the priority tray that the machine will use for printing copies.

When you choose **Tray#1 Only**, **MP Only** or **Tray#2 Only**<sup>1</sup>, the machine pulls the paper only from that tray. If the selected tray is out of paper, **No Paper** will appear on the LCD. Insert paper in the empty tray.

To change the tray setting follow the instructions below:

- 1 Press **Menu**, **1**, **5**, **1**.
- 2 Press **▲** or **▼** to choose **Tray#1 Only**, **Tray#2 Only**<sup>1</sup>, **MP Only**, **MP>T1>T2**<sup>1</sup> or **T1>T2**<sup>1</sup>>**MP**. Press **OK**.
- <sup>1</sup> **Tray#2 Only** and **T2** appear only if the optional lower tray is installed.
- 3 Press **Stop/Exit**.



### Note

- When loading documents in the ADF and **MP>T1>T2** or **T1>T2>MP** is selected, the machine looks for the tray with the most suitable paper and pulls paper from that tray. If no tray has suitable paper, the machine pulls paper from the higher priority tray.
- When using the scanner glass, your document is copied from the higher priority tray even if more suitable paper is in another paper tray.

## Tray Use in print mode

You can change the default tray the machine will use for printing from your computer and Direct Print.

- 1 Press **Menu**, **1**, **5**, **2**.
- 2 Press **▲** or **▼** to choose **Tray#1 Only**, **Tray#2 Only**<sup>1</sup>, **MP Only**, **MP>T1>T2**<sup>1</sup> or **T1>T2**<sup>1</sup>>**MP**. Press **OK**.
- <sup>1</sup> **Tray#2 Only** and **T2** appear only if the optional lower tray is installed.
- 3 Press **Stop/Exit**.

## Acceptable paper and other print media

Print quality may vary according to the type of paper you are using.

You can use the following types of print media: plain paper, thin paper, thick paper, thicker paper, bond paper, recycled paper, labels or envelopes.

For best results, follow the instructions below:

- DO NOT put different types of paper in the paper tray at the same time because it may cause paper jams or misfeeds.
- For correct printing, you must choose the same paper size from your software application as the paper in the tray.
- Avoid touching the printed surface of the paper immediately after printing.
- Before you buy a lot of paper, test a small quantity to make sure the paper is suitable.
- Use labels that are designed for use in laser machines.

## Recommended paper and print media

| Paper Type     | Item                                       |
|----------------|--|
| Plain paper    | Xerox Premier TCF 80 g/m <sup>2</sup>      |
|                | Xerox Business 80 g/m <sup>2</sup>         |
| Recycled Paper | Xerox Recycled Supreme 80 g/m <sup>2</sup> |
| Labels         | Avery laser label L7163                    |
| Envelopes      | Antalis River series (DL)                  |

## Type and size of paper

The machine feeds paper from the installed standard paper tray, multi-purpose tray or optional lower tray.

**The names for the paper trays in the printer driver and this Guide are as follows:**

| Tray and optional unit | Name    |
|------------------------|---------|
| Standard Paper Tray    | Tray 1  |
| Multi-purpose Tray     | MP Tray |
| Optional Lower Tray    | Tray 2  |

## Paper capacity of the paper trays

|                              | Paper size   | Paper types  | No. of sheets                                   |
|------------------------------|--|--|---|
| Standard Paper Tray (Tray 1) | A4, Letter, Legal, B5, Executive, A5, A5 (Long Edge), A6, B6, Folio <sup>1</sup> | Plain paper, Thin paper, Recycled paper  | up to 250 (80 g/m <sup>2</sup> )                |
| Multi-purpose Tray (MP Tray) | Width: 76.2 to 215.9 mm<br>Length: 127.0 to 355.6 mm                             | Plain paper, Thin paper, Thick paper, Thicker paper, Bond paper, Recycled paper, Envelopes, Labels | 50 sheets (80 g/m <sup>2</sup> )<br>3 Envelopes |
| Optional Lower Tray (Tray 2) | A4, Letter, Legal, B5, Executive, A5, B6, Folio <sup>1</sup>                     | Plain paper, Thin paper, Recycled paper  | up to 500 (80 g/m <sup>2</sup> )                |

<sup>1</sup> Folio size is 8.5 in. × 13 in.

## Recommended paper specifications

The following paper specifications are suitable for this machine.

|                     |  |
|---------------------|--|
| Basis weight        | 75-90 g/m <sup>2</sup>                     |
| Thickness           | 80-110 μm                                  |
| Roughness           | Higher than 20 sec.                        |
| Stiffness           | 90-150 cm <sup>3</sup> /100                |
| Grain direction     | Long grain                                 |
| Volume resistivity  | 10e <sup>9</sup> -10e <sup>11</sup> ohm    |
| Surface resistivity | 10e <sup>9</sup> -10e <sup>12</sup> ohm-cm |
| Filler              | CaCO <sub>3</sub> (Neutral)                |
| Ash content         | Below 23 wt%                               |
| Brightness          | Higher than 80%                            |
| Opacity             | Higher than 85%                            |

- Use paper made for plain paper copying.
- Use paper that is 75 to 90 g/m<sup>2</sup>.
- Use long grain paper with a neutral Ph value, and a moisture content of approx. 5%.
- This machine can use recycled paper that meets DIN 19309 specifications.

## Handling and using special paper

The machine is designed to work well with most types of xerographic and bond paper. However, some paper variables may have an effect on print quality or handling reliability. Always test samples of paper before purchasing to ensure desirable performance. Store paper in its original packaging and keep it sealed. Keep the paper flat and away from moisture, direct sunlight and heat.

Some important guidelines when selecting paper are:

- DO NOT use inkjet paper because it may cause a paper jam or damage your machine.
- Preprinted paper must use ink that can withstand the temperature of the machine's fusing process 200 °C.
- If you use bond paper, paper with a rough surface, or paper that is wrinkled or creased, the paper may exhibit degraded performance.

## Types of paper to avoid

### ! Important

Some types of paper may not perform well or may cause damage to your machine.

DO NOT use paper:

- that is highly textured
- that is extremely smooth or shiny
- that is curled or warped

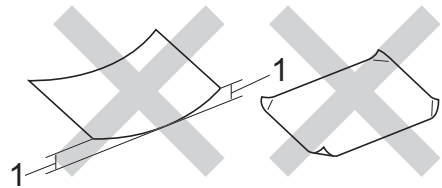

**1 A curl of 2 mm or greater may cause jams to occur.**

- that is coated or has a chemical finish
- that is damaged, creased or folded
- that exceeds the recommended weight specification in this guide
- with tabs and staples
- with letterheads using low temperature dyes or thermography
- that is multipart or carbonless
- that is designed for inkjet printing

The types of paper listed above may damage your machine. This damage is not covered under any Brother warranty or service agreement.

## Envelopes

Most envelopes designed for laser printers will be suitable for your machine. However, some envelopes may have feed and print-quality problems because of the way they have been made. A suitable envelope should have edges with straight, well-creased folds. The envelope should lie flat and not be of baggy or flimsy construction. You should buy quality envelopes from a supplier who understands that you will be using the envelopes in a laser machine.

Envelopes can only be fed through the MP tray.

We recommend that you print a test envelope to make sure the print results are what you want before printing a large amount of envelopes.

### Types of envelopes to avoid

#### ❗ Important

DO NOT use envelopes:

- that are damaged, curled, wrinkled or an unusual shape
- that are extremely shiny or textured
- with clasps, staples, snaps or tie strings
- with self-adhesive closures
- that are of a baggy construction
- that are not sharply creased
- that are embossed (have raised writing on them)
- that were previously printed by a laser machine
- that are pre-printed on the inside
- that cannot be arranged neatly when stacked
- that are made of paper that weighs more than the paper weight specifications for the machine
- with edges that are not straight or consistently square

- with windows, holes, cut-outs or perforations
- with glue on the surface as shown in the figure below

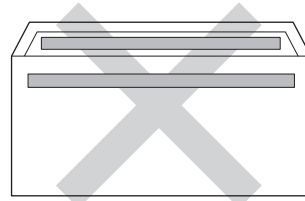

- with double flaps as shown in the figure below

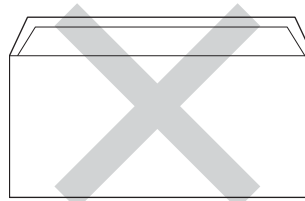

- with sealing flaps that are not folded down when purchased
- with each side folded as shown in the figure below

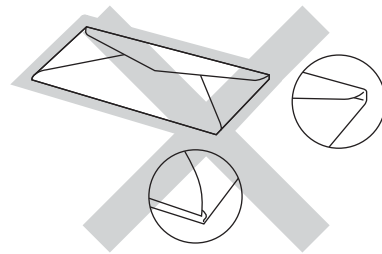

If you use any of the types of envelopes listed above, they may damage your machine. This damage may not be covered under any Brother warranty or service agreement.

Occasionally you may experience paper feed problems caused by the thickness, size and flap shape of the envelopes you are using.

## Labels

The machine will print on most types of labels designed for use with a *laser* machine. Labels should have an adhesive that is acrylic-based since this material is more stable at the high temperatures in the fuser unit. Adhesives should not come in contact with any part of the machine. If this happens, the label stock may stick to the drum unit or rollers and cause jams and print quality problems. No adhesive should be exposed between the labels. Labels should be arranged so that they cover the entire length and width of the sheet. Using labels with spaces may result in labels peeling off and causing serious jams or print problems.

All labels used in this machine must be able to withstand a temperature of 200 °C for a period of 0.1 seconds.

Labels can only be fed through the MP tray.

## Types of labels to avoid

Do not use labels that are damaged, curled, wrinkled or an unusual shape.

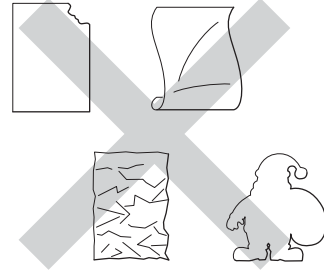

### ! Important

- DO NOT feed part used label sheets. The exposed carrier sheet will damage your machine.
- Label sheets should not exceed the paper weight specifications described in this User's Guide. Labels exceeding this specification may not feed or print correctly and may cause damage to your machine.
- DO NOT reuse or insert labels that have previously been used or are missing a few labels on the sheet.

# 3

## Loading documents

### How to load documents

You can copy and scan from the ADF (automatic document feeder) or the scanner glass.

### Using the automatic document feeder (ADF)

The ADF can hold up to 35 pages and feeds each sheet individually. We recommend you use standard 80 g/m<sup>2</sup> paper and always fan the pages before putting them in the ADF.

#### Document Sizes Supported

|         |                           |
|---------|---------------------------|
| Length: | 147.3 to 355.6 mm         |
| Width:  | 147.3 to 215.9 mm         |
| Weight: | 64 to 90 g/m <sup>2</sup> |

#### How to load documents

##### ! Important

- DO NOT leave thick documents on the scanner glass. If you do this, the ADF may jam.
- DO NOT use paper that is curled, wrinkled, folded, ripped, stapled, paper-clipped, pasted or taped.
- DO NOT use cardboard, newspaper or fabric.
- To avoid damaging your machine while using the ADF, DO NOT pull on the document while it is feeding.



##### Note

- To scan documents that are not suitable for the ADF, see *Using the scanner glass* >> page 25.
- It is easier to use the ADF if you are loading a multiple page document.
- Make sure documents with correction fluid or written with ink are completely dry.

- 1 Unfold the ADF document support (1). Lift up and unfold the ADF document output support flap (2).

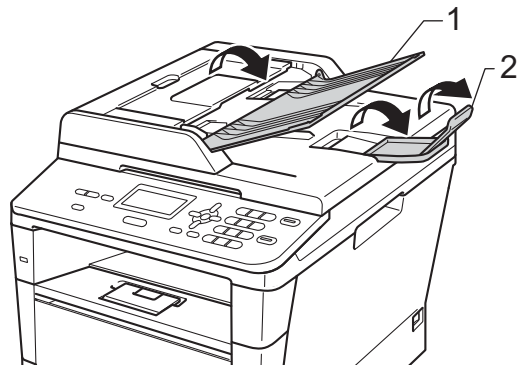

- 2 Fan the pages well.
- 3 Stagger the pages of your document *face up top edge first*, in the ADF until the LCD display message changes and you feel the top page touch the feed rollers.



- 4 Adjust the paper guides (1) to fit the width of your document.

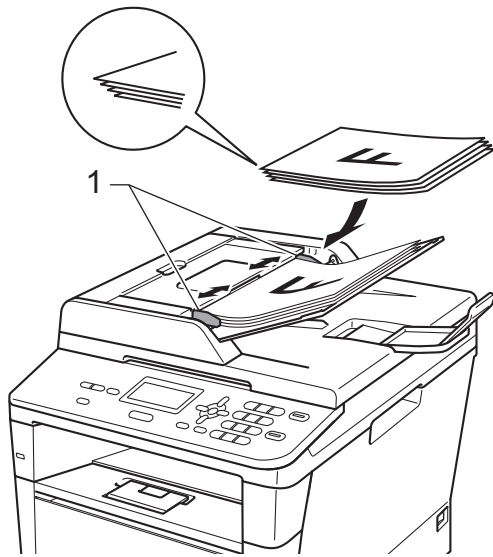

### Note

To scan non-standard documents, see *Using the scanner glass* >> page 25.

## Using the scanner glass

You can use the scanner glass to copy or scan pages of a book, one page at a time.

### Document Sizes Supported

|         |                |
|---------|----------------|
| Length: | Up to 300.0 mm |
| Width:  | Up to 215.9 mm |
| Weight: | Up to 2.0 kg   |

## How to load documents



### Note

To use the scanner glass, the ADF must be empty.

- 1 Lift the document cover.
- 2 Using the document guidelines on the left and top, place the document *face down* in the upper left corner of the scanner glass.

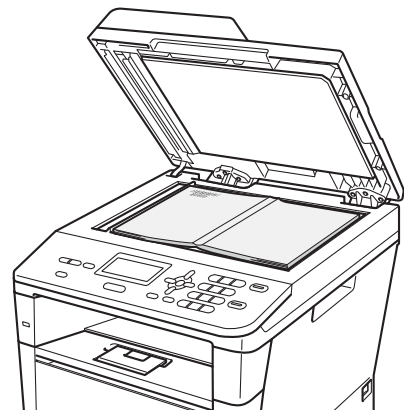
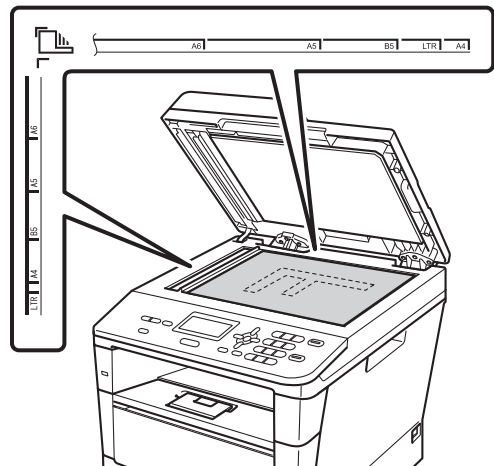

- 3 Close the document cover.



### Important

If the document is a book or is thick do not slam the cover or press on it.

# 4

## Making copies

### How to copy

The following steps show the basic copy operation.

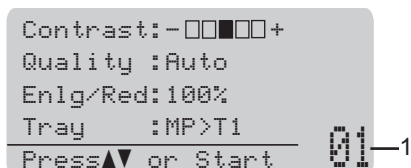

#### 1 No. of Copies

Use the numeric pad to enter the number of copies you want.

- 1 Do one of the following to load your document:
  - Place the document *face up* in the ADF. (See *Using the automatic document feeder (ADF)* >> page 24.)
  - Load your document *face down* on the scanner glass. (See *Using the scanner glass* >> page 25.)

- 2 Press **Start**.

### Stop copying

---

To stop copying, press **Stop/Exit**.

### Copy settings

---

Press temporary **COPY** keys or **Duplex** and then press ▲, ▼, ◀ or ▶ to scroll through the copy settings. When the setting you want is highlighted, press **OK**.

(Basic User's Guide)

For details about changing the following settings >> page 17 - 18:

- Paper Type
- Paper Size
- Tray Use (Tray Use in COPY mode)

(Advanced User's Guide)

For details about changing the following settings >> Advanced User's Guide: *Copy settings*:

- Enlg/Red (Enlarge/Reduce)
- Stack/Sort
- Quality
- Brightness
- Contrast
- Page Layout
- Tray Select (Tray Selection)
- Duplex

# 5

## Printing data from a USB Flash memory drive or digital camera supporting mass storage

With the Direct Print feature, you do not need a computer to print data. You can print by just plugging your USB Flash memory drive into the machine's USB direct interface. You can also connect and print directly from a camera set to USB mass storage mode.

You can use a USB Flash Memory Drive that has the following specifications:

| USB Class              | USB Mass Storage Class               |
|------------------------|--------------------------------------|
| USB Mass Storage Class | SCSI or SFF-8070i                    |
| Transfer protocol      | Bulk transfer Only                   |
| Format <sup>1</sup>    | FAT12/FAT16/FAT32                    |
| Sector size            | Max. 4096Byte                        |
| Encryption             | Encrypted devices are not supported. |

<sup>1</sup> NTFS format is not supported.



### Note

- Some USB Flash memory drives may not work with the machine.
- If your camera is in PictBridge mode, you cannot print data. Please refer to the documentation supplied with your camera to switch from PictBridge mode to mass storage mode.

## Creating a PRN file for direct printing



### Note

The screens in this section may vary depending on your application and operating system.

- 1 From the menu bar of an application, click **File**, then **Print**.

- 2 Choose **Brother DCP-XXXX Printer** (1) and check the **Print to file** box (2). Click **Print**.

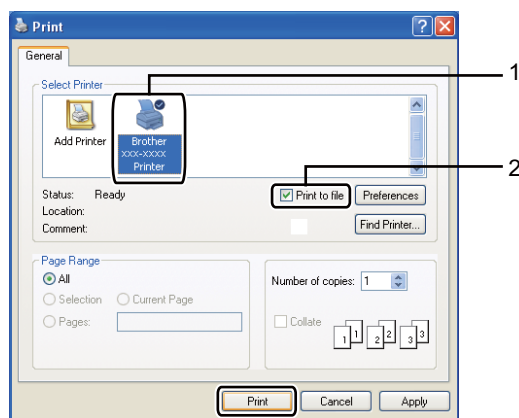

- 3 Choose the folder you want to save the file to and enter the file name if you are prompted to.

If you are prompted for a file name only, you can also specify the folder you want to save the file in by entering the directory name. For example:

C:\Temp\FileName.prn

If you have a USB Flash memory drive or digital camera connected to your computer, you can save the file directly to the USB Flash memory drive.

## Printing data directly from the USB Flash memory drive or digital camera supporting mass storage

- 1 Connect your device to the USB direct interface (1) on the front of the machine. Your machine will enter Direct Print mode automatically. The LCD will automatically show the USB memory menu to confirm the intended use of the device.

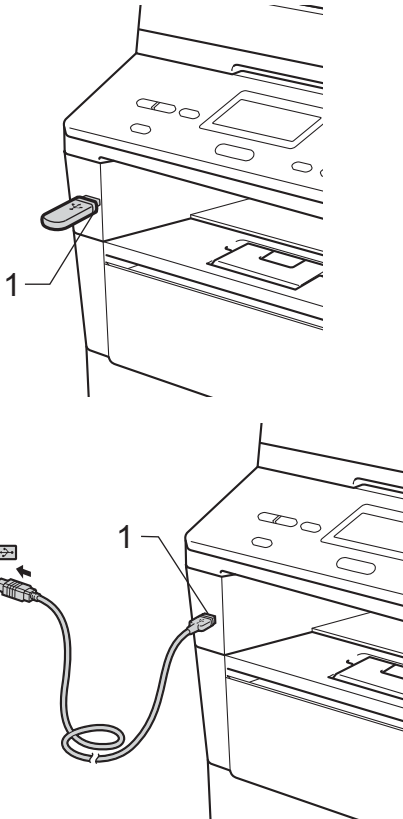

### Note

- Make sure your digital camera is turned on.
- If an error occurs, the USB memory options *Direct Print* and *Scan to USB* will not appear on the LCD.
- When the machine is in the Deep Sleep mode, the LCD does not show any information even if you connect a device to the USB direct interface. Press **Stop/Exit** on the control panel to wake up the machine.

- 2 Press ▲ or ▼ to choose 1. *Direct Print*. Press **OK**.

### Note

- If *Direct Print* is restricted in *Secure Function Lock 2.0* for your User ID, and access has been given to another User ID or Public mode, *Access Denied* will appear on the LCD. Then the LCD will show *Change ID* and other User IDs so you may switch to a User ID or Public mode that has access.

If you are a restricted user with access to *Direct Print*, press ▲ or ▼ to choose your name and press **OK**. Enter your four-digit password and press **OK**.

- If your machine has been set to *Secure Function Lock On*, you may not be able to access *Direct Print*. (►► *Advanced User's Guide: Switching Users*)
- If your ID has been restricted to a page limit in *Secure Function Lock*, the LCD will show *Remaining Pages* with the number of pages you have left to print.

- 3 Press ▲ or ▼ to choose the folder name or file name you want to print. Press **OK**.  
If you have chosen the folder name, press ▲ or ▼ to choose the file name you want to print.  
Press **OK**.

```
Direct Print
▲1. /FOLDER1
 2.FILE_1.PDF
▼3.FILE_2.PDF
Select ▲▼ or OK
```



### Note

- Your digital camera must be switched from PictBridge mode to mass storage mode.
- If you want to print an index of the files, choose *Index Print*, and then press **OK**. Press **Start** to print the data.

- 4 Do one of the following:
- Press ▲ or ▼ to choose a setting you need to change and press **OK**, then press ▲ or ▼ to choose an option for the setting and press **OK**.
  - If you do not want to change the current default settings, go to step 5.

```
Print File Set
▲Paper Size
  Media Type
▼Multiple Page
Select ▲▼ or OK
```



### Note

- You can change the following settings:
  - Paper Size
  - Media Type
  - Multiple Page
  - Orientation
  - Duplex
  - Collate
  - Tray Use
  - Print Quality
  - PDF Option
- Depending on the file type, some of these settings may not appear.

- 5 Press **Start** if you have finished selecting settings.

- 6 Use the numeric keys to enter the number of copies you want. Press **OK**.

```
Direct Print
FILE_1.PDF
  No. of Copies: 1
Press Start
```

- 7 Press **Start** to print the data.

- 8 Press **Stop/Exit**.

### Important

- To prevent damage to your machine, **DO NOT** connect any device other than a digital camera or USB Flash memory drive to the USB direct interface.
- DO NOT** remove the USB Flash memory drive or digital camera from the USB direct interface until the machine has finished printing.



**Note**

---

- You can change the default tray that the machine will use for printing. Press **Menu, 1, 5, 2**, and then press **▲** or **▼** to select the tray you want as the new default. Press **OK**.

(See *Tray Use in print mode* >> page 18.)

- You can change the default settings for Direct Print by using the control panel when the machine is not in the Direct Print mode. Press **Menu, 4** to enter the USB Direct I/F menu. (See *Menu table* >> page 96.)
-

## Printing a document

The machine can receive data from your computer and print it. To print from a computer you must install the printer driver.

(➤➤ Software User's Guide: *Printing* for Windows® or *Printing and Faxing* for Macintosh)

- 1 Install the Brother printer driver from the Installer CD-ROM. (➤➤ Quick Setup Guide)
- 2 From your application, choose the Print command.
- 3 Choose the name of your machine in the **Print** dialog box and click **Properties** (or **Preferences**, depending on the application you are using).
  - Paper Size
  - Orientation
  - Copies
  - Media Type
  - Resolution
  - Print Settings
  - Multiple Page
  - Duplex / Booklet
  - Paper Source
- 5 Click **OK** to begin printing.

# 7

## How to scan to a computer

### Scanning a document as a PDF file using ControlCenter4 (Windows®)

(Detailed information >> Software User's Guide: *Scanning*)



#### Note

The screens on your PC may vary depending on your model.

ControlCenter4 is a software utility that lets you quickly and easily access the applications you use most often. Using ControlCenter4 eliminates the need to manually launch specific applications.

- 1 Load your document. (See *How to load documents* >> page 24.)
- 2 Open ControlCenter4 by clicking **Start/All Programs/Brother/XXX-XXXX** (where XXX-XXXX is your model name)/**ControlCenter4**. The ControlCenter4 application will open.
- 3 Choose **Home Mode** or **Advanced Mode** before you use ControlCenter4 and then click **OK**. This section briefly introduces the ControlCenter4 functions in **Advanced Mode**.

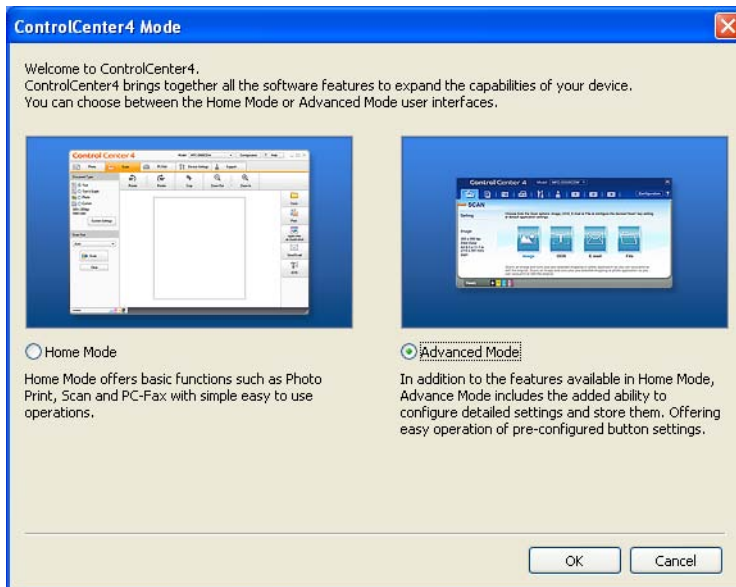

- 4 Make sure the machine you want to use is selected from the **Model** pull-down list.



- 5 Set the scanning configuration.  
Click **Configuration**, then select **Button settings**, **Scan** and **File**.

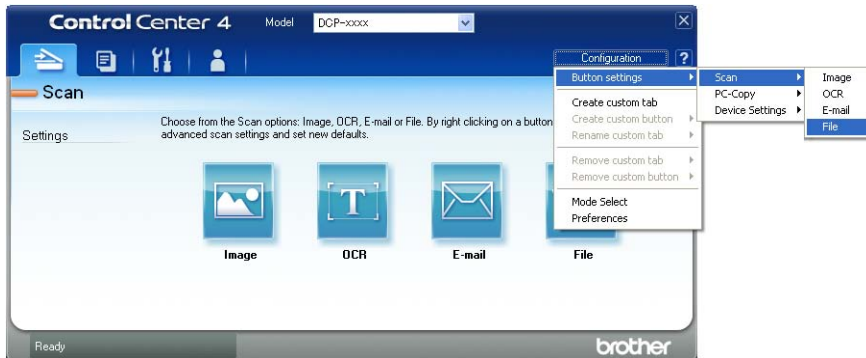

The configuration dialog box appears. You can change the default settings.

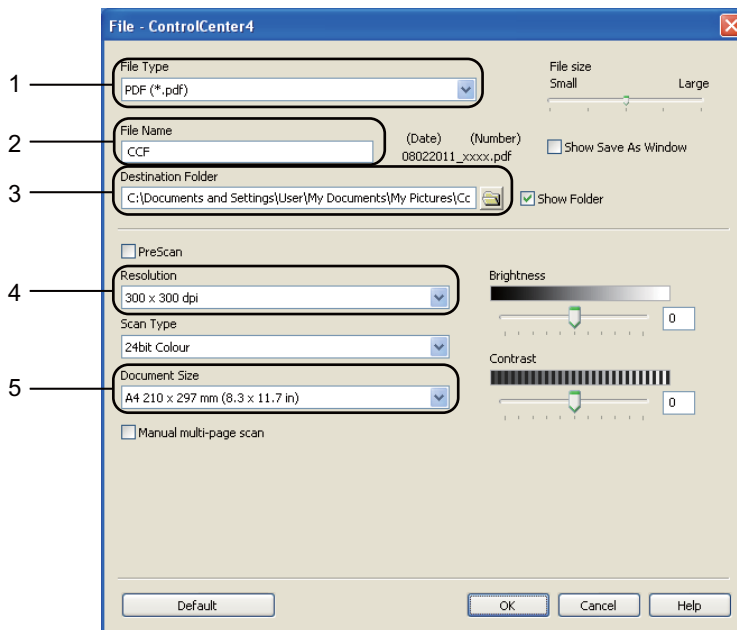

- 1 Confirm **PDF (\*.pdf)** is selected from the **File Type** pull-down list.
- 2 You can enter the file name you want to use for the document.
- 3 You can save the file to the default folder, or choose your preferred folder by clicking the  (**Browse**) button.
- 4 You can choose a scanning resolution from the **Resolution** pull-down list.
- 5 You can choose the document size from the **Document Size** pull-down list.

- 6 Click **OK**.

7

Click **File**.

The machine starts the scanning process. The folder where the scanned data is saved will open automatically.

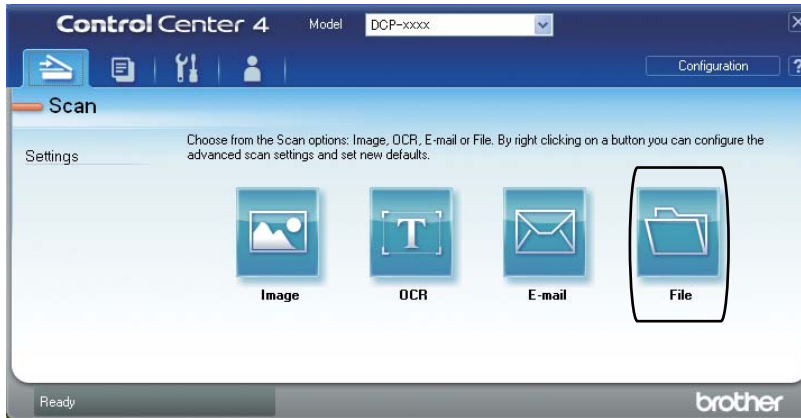

# Changing the SCAN key settings

## Before scanning

To use the machine as a scanner, install a scanner driver. If the machine is on a network, configure it with a TCP/IP address.

- Install the scanner drivers from the Installer CD-ROM. (▶▶ Quick Setup Guide)
- Configure the machine with a TCP/IP address if network scanning does not work. (▶▶ Software User's Guide: *Configuring Network Scanning (Windows®)*)

## SCAN key settings

You can change your machine's **SCAN** key settings using ControlCenter4.

- 1 Open ControlCenter4 by clicking **Start/All Programs/Brother/XXX-XXXX** (where XXX-XXXX is your model name)/**ControlCenter4**. The ControlCenter4 application will open.
- 2 Make sure the machine you want to use is selected from the **Model** pull-down list.
- 3 Click the **Device Settings** tab.
- 4 Click **Device Scan Settings**.

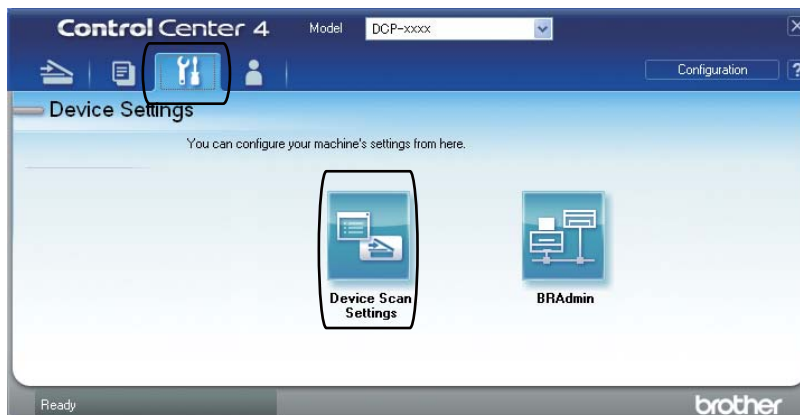

- 5 Choose the **File** tab. You can change the default settings.

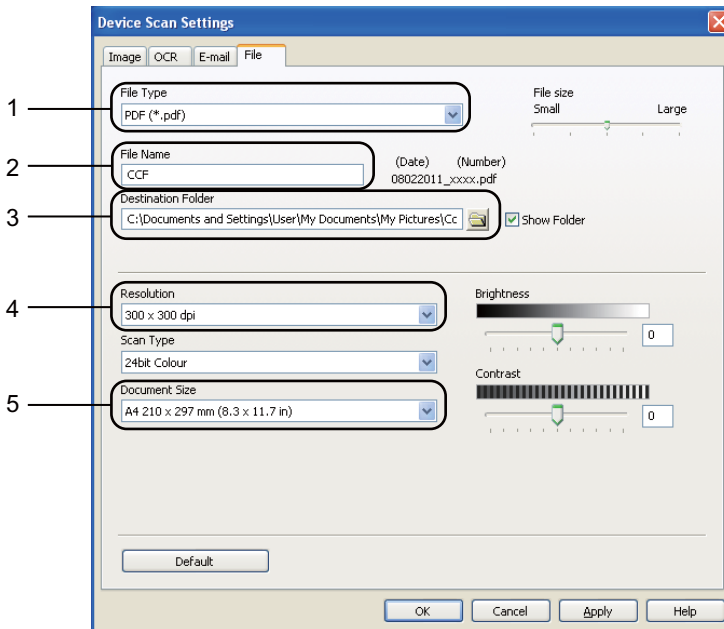

- 1 You can choose the file type from the pull-down list.
- 2 You can enter the file name you want to use for the document.
- 3 You can save the file to the default folder, or choose your preferred folder by clicking the  (**Browse**) button.
- 4 You can choose a scanning resolution from the **Resolution** pull-down list.
- 5 You can choose the document size from the **Document Size** pull-down list.

- 6 Click **OK**.

## Scanning using the SCAN key

---

- 1 Load your document. (See *How to load documents* >> page 24.)
- 2 Press  (**SCAN**).
- 3 Press ▲ or ▼ to choose `Scan to PC`.  
Press **OK**.
- 4 Press ▲ or ▼ to choose `File`.  
Press **OK**.
- 5 (For Network users)  
Press ▲ or ▼ to choose the destination computer you want to send to.  
Press **OK**.  
If the LCD prompts you to enter a PIN number, enter the 4-digit PIN number for the destination computer using the numeric keys on the control panel.  
Press **OK**.
- 6 Press ▲ or ▼ to choose `Start Scan`.  
Press **OK**.
- 7 Press **Start**.  
The machine starts the scanning process.



### Note

---

The following scan modes are available:

Scan to:

- USB
- Network (Windows®)
- Image (Scan to PC)
- OCR (Scan to PC)
- E-mail (Scan to PC)
- File (Scan to PC)
- FTP
- Web Service<sup>1</sup> (Web Services Scan)

---

<sup>1</sup> Windows® users only. (Windows Vista® SP2 or later and Windows® 7)  
(>> Software User's Guide: *Using Web Services for scanning on your network (Windows Vista® SP2 or greater and Windows® 7)*)

# A

## Routine maintenance

### Replacing the consumable items

The following messages appear on the LCD in the Ready mode. These messages provide advanced warnings to replace the consumable items before they reach the end of their life. To avoid any inconvenience, you may want to buy spare consumable items before the machine stops printing.



#### Note

The drum unit and toner cartridge are two separate consumables. Make sure both are installed as an assembly. If the toner cartridge is placed in the machine without the drum unit, the messages `Drum Error` or `Jam Inside` may be displayed.

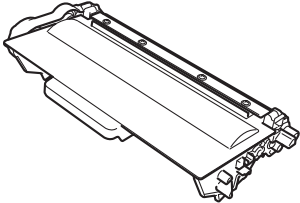
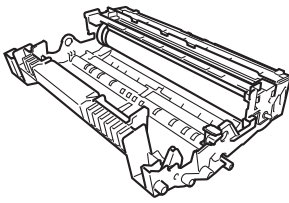
| Toner cartridge  | Drum unit   |
|--|---|
| See <i>Replacing the toner cartridge</i> >> page 40.<br>Model Name: TN-3330, TN-3380 | See <i>Replacing the drum unit</i> >> page 46.<br>Model Name: DR-3300               |
|    |  |

| LCD messages                 | Consumable item to prepare | Approximate life             | How to replace | Model name           |
|------------------------------|----------------------------|------------------------------|----------------|----------------------|
| Toner Low                    | Toner cartridge            | 3,000 pages <sup>1 2 3</sup> | See page 40.   | TN-3330 <sup>3</sup> |
| Prepare New Toner Cartridge. |                            | 8,000 pages <sup>1 2 4</sup> |                | TN-3380 <sup>4</sup> |

<sup>1</sup> A4 or Letter size single-sided pages.

<sup>2</sup> Approx. cartridge yield is declared in accordance with ISO/IEC 19752.

<sup>3</sup> Standard toner cartridge

<sup>4</sup> High yield toner cartridge

You will need to clean the machine regularly and replace the consumable items when the following messages are displayed on the LCD.

| LCD messages          | Consumable item to replace | Approximate life   | How to replace | Model name                                   |
|-----------------------|----------------------------|--|----------------|--|
| Replace Toner         | Toner cartridge            | 3,000 pages <sup>1 2 5</sup><br>8,000 pages <sup>1 2 6</sup> | See page 40.   | TN-3330 <sup>5</sup><br>TN-3380 <sup>6</sup> |
| Replace Parts<br>Drum | Drum unit                  | 30,000 pages <sup>1 3 4</sup>                                | See page 47.   | DR-3300                                      |
| Drum Stop             |                            |  |                |  |

<sup>1</sup> A4 or Letter size single-sided pages.

<sup>2</sup> Approx. cartridge yield is declared in accordance with ISO/IEC 19752.

<sup>3</sup> 1 page per job.

<sup>4</sup> Drum life is approximate and may vary by type of use.

<sup>5</sup> Standard toner cartridge

<sup>6</sup> High yield toner cartridge



### Note

- Go to <http://www.brother.com/original/index.html> for instructions on how to return your used consumable items to the Brother recycling program. If you choose not to return your used items, please discard the used consumable according to local regulations, keeping it separate from domestic waste. If you have questions, call your local waste disposal office. (►► Product Safety Guide: *Recycling information in accordance with the WEEE (2002/96/EC) and Battery (2006/66/EC) Directives*)
- We recommend placing used consumable items on a piece of paper to prevent accidentally spilling or scattering the material inside.
- If you use paper that is not a direct equivalent for the recommended paper, the life of consumable items and machine parts may be reduced.
- The projected life for each of the toner cartridges is based on ISO/IEC 19752. Frequency of replacement will vary depending on the complexity of printed pages, percentage of coverage and type of media used.

## Replacing the toner cartridge

Model Name: TN-3330, TN-3380

The Standard toner cartridge can print approximately 3,000 pages<sup>1</sup>. The High Yield toner cartridge can print approximately 8,000 pages<sup>1</sup>. Actual page count will vary depending on your average type of document.

When the toner cartridge is running low, the LCD shows `Toner Low`.

The toner cartridge that comes supplied with the machine will need to be replaced after approximately 2,000 pages<sup>1</sup>.

<sup>1</sup> Approx. cartridge yield is declared in accordance with ISO/IEC 19752.



### Note

- It is a good idea to keep a new toner cartridge ready for use when you see the `Toner Low` warning.
- To ensure high quality printing, we recommend that you use only Brother Original toner cartridges. When you want to buy toner cartridges, please call your Brother dealer.
- If you print graphics, bold text, charts, web pages with borders, and other types of printouts that consist of more than simple text, the amount of toner used will increase.
- We recommend that you clean the machine when you replace the toner cartridge. See *Cleaning and Checking the machine* >> page 51.
- If you change the print density setting for lighter or darker printing, the amount of toner used will change.
- Wait to unpack the toner cartridge until immediately before you put it into the machine.

## Toner Low

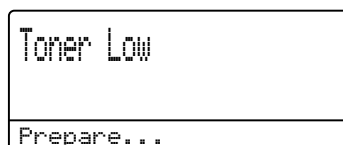

If the LCD shows `Toner Low`, buy a new toner cartridge and have it ready before you get a `Replace Toner` message.

## Replace Toner

When the following message appears on the LCD, you need to replace the toner cartridge:



The machine will stop printing until you replace the toner cartridge. A new Brother Original toner cartridge will clear the replace toner message.



## Replacing the toner cartridge

- 1 Leave the machine turned on for 10 minutes for the internal fan to cool the extremely hot parts inside the machine.
- 2 Press the front cover release button and then open the front cover.

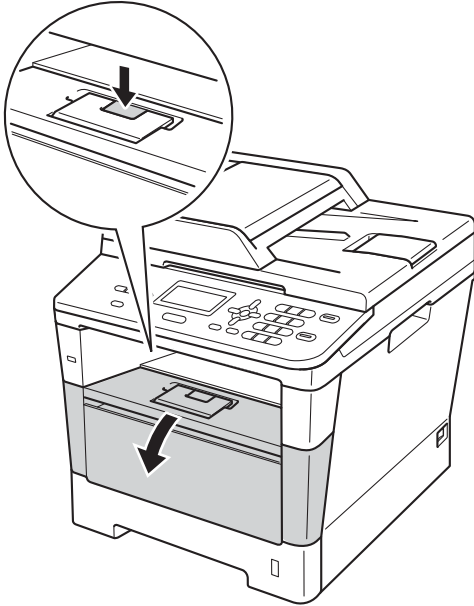

- 3 Take out the drum unit and toner cartridge assembly.

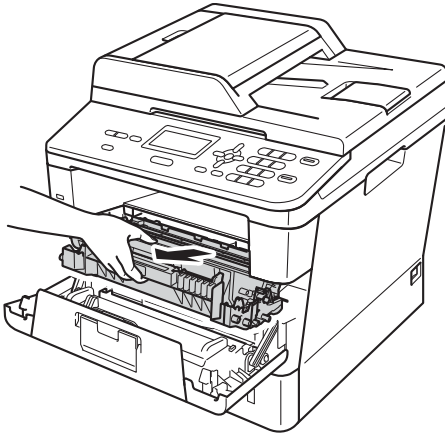

## ! WARNING

### ! HOT SURFACE

After you have just used the machine, some internal parts of the machine will be extremely hot. Wait for the machine to cool down before you touch the internal parts of the machine.

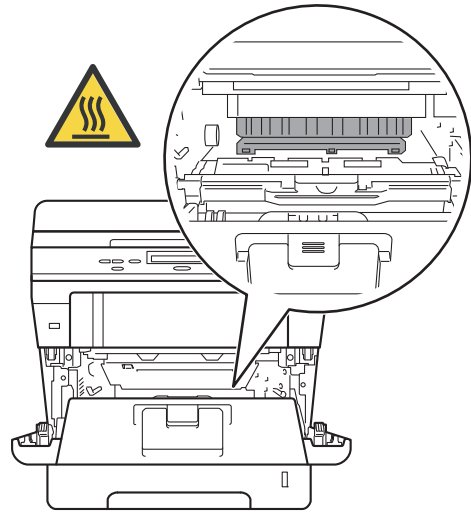

## ! Important

- We recommend that you place the drum unit and toner cartridge assembly on a clean, flat surface with a piece of disposable paper underneath it in case you accidentally spill or scatter toner.
- To prevent damage to the machine from static electricity, DO NOT touch the electrodes shown in the illustration.

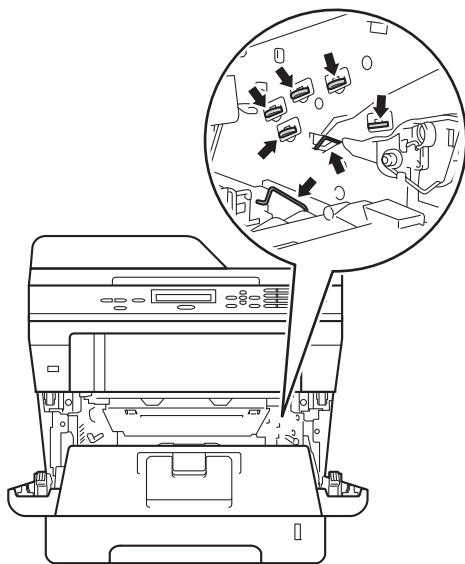

- 4 Push down the green lock lever and take the toner cartridge out of the drum unit.

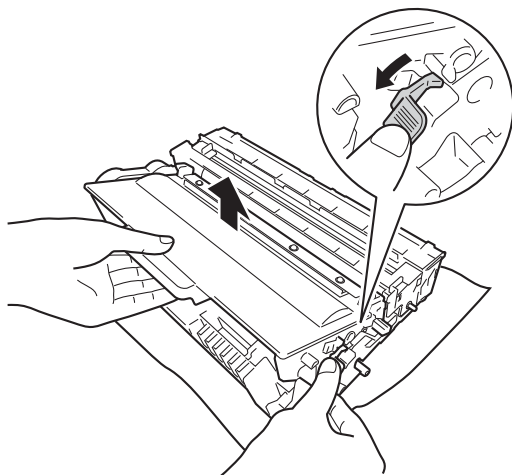

## ! WARNING



- DO NOT put a toner cartridge or a toner cartridge and drum unit assembly into a fire. It could explode, resulting in injuries.
- DO NOT use flammable substances, any type of spray, or an organic solvent/liquid containing alcohol or ammonia to clean the inside or outside of the machine. Doing so could cause a fire or electrical shock. Instead, use only a dry, lint-free cloth.

(>> Product Safety Guide: *General precautions*)



**! Important**

- Handle the toner cartridge carefully. If toner scatters on your hands or clothes, immediately wipe or wash it off with cold water.
- To avoid print quality problems, DO NOT touch the shaded parts shown in the illustrations.

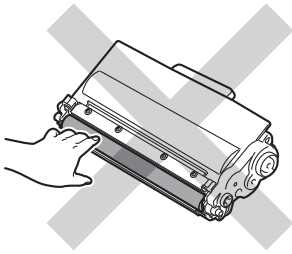
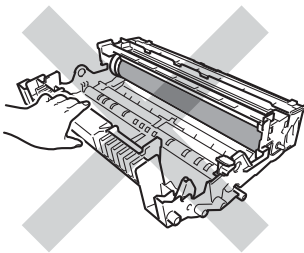
**<Toner cartridge>****<Drum unit>**

- We recommend that you place the toner cartridge on a clean, flat, level, stable surface with a sheet of disposable paper or cloth underneath it in case you accidentally spill or scatter toner.

**Note**

- Be sure to seal up the used toner cartridge tightly in a suitable bag so that toner powder does not spill out of the cartridge.
- Go to <http://www.brother.com/original/index.html> for instructions on how to return your used items to the Brother recycling program. If you choose not to return your used items, please discard the used items according to local regulations, keeping it separate from domestic waste. If you have questions, call your local waste disposal office.

(>> Product Safety Guide: *Recycling information in accordance with the WEEE (2002/96/EC) and Battery (2006/66/EC) Directives*)

5. Unpack the new toner cartridge. Hold the cartridge level with both hands and gently shake it from side to side several times to spread the toner evenly inside the cartridge.

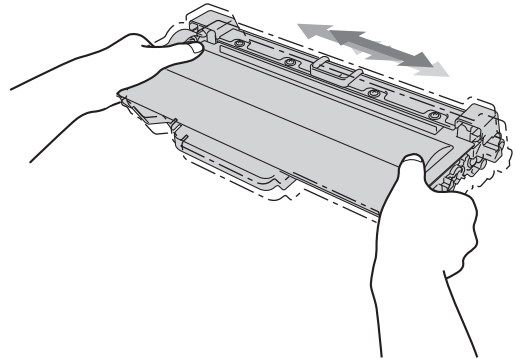

## ! Important

- Unpack the toner cartridge just before you put it in the machine. If a toner cartridge is left unpacked for a long time, the toner life will be shortened.
- If an unpacked drum unit is put in direct sunlight or room light, the unit may be damaged.
- Brother machines are designed to work with toner of a particular specification and will work to a level of optimum performance when used with Brother Original toner cartridges. Brother cannot guarantee this optimum performance if toner or toner cartridges of other specifications are used. The machine may not detect toner or toner cartridges of other specifications correctly but may instead detect such items as standard yield toner cartridges. Brother does not therefore recommend the use of cartridges other than Brother Original cartridges with this machine, or the refilling of empty cartridges with toner from other sources. If damage is caused to the drum unit or other parts of this machine as a result of the use of toner or toner cartridges other than Brother Original products, due to the incompatibility or lack of suitability of those products with this machine, any repairs required as a result may not be covered by the warranty.

- 6 Pull off the protective cover.

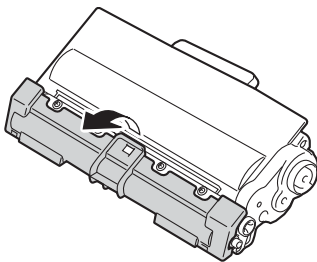

## ! Important

Put the toner cartridge in the drum unit immediately after you have removed the protective cover. To prevent any degradation to the print quality, DO NOT touch the shaded parts shown in the illustrations.

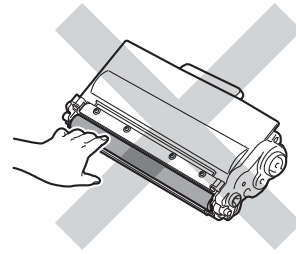

- 7 Put the new toner cartridge firmly into the drum unit until you hear it lock into place. If you put it in correctly, the green lock lever on the drum unit will lift automatically.

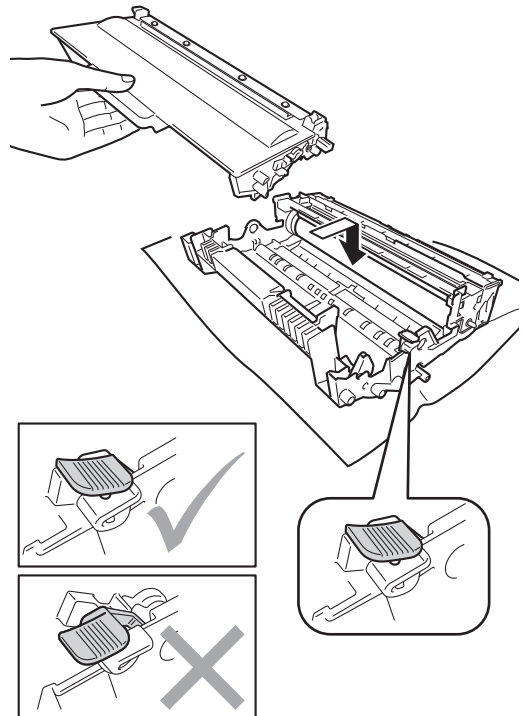



**Note**

Make sure that you put in the toner cartridge correctly or it may separate from the drum unit.

- 8 Clean the corona wire inside the drum unit by gently sliding the green tab back and forth several times.

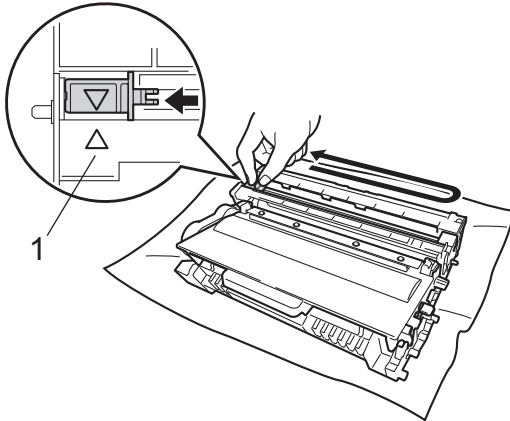

**Note**

Be sure to return the tab to the home position (▲) (1). If you do not, printed pages may have a vertical stripe.

- 9 Put the drum unit and toner cartridge assembly back into the machine.

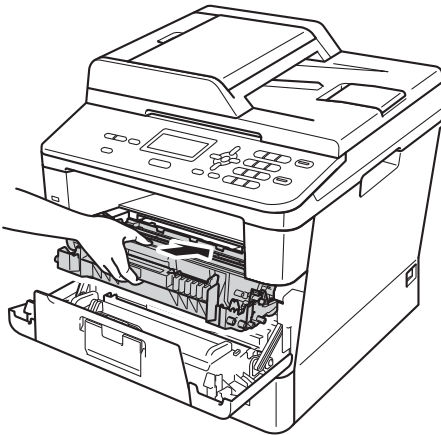

- 10 Close the front cover of the machine.



**Note**

After you replace a toner cartridge, DO NOT turn off the machine's power switch or open the front cover until the LCD clears the Please Wait message and returns to Ready mode.

## Replacing the drum unit

Model name: DR-3300

A new drum unit can print approximately 30,000 A4 or Letter size single-sided pages.

### ! Important

For best performance, use a Brother Original drum unit and Brother Original toner units. Printing with a third-party drum unit or toner unit may reduce not only the print quality but also the quality and life of the machine itself. Warranty coverage may not apply to problems caused by the use of a third-party drum or toner unit.

## Drum Error

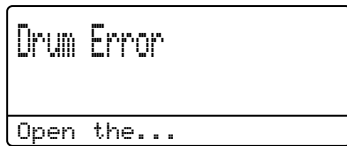

The corona wire has become dirty. Clean the corona wire in the drum unit. (See *Cleaning the corona wire* >> page 53.)

If you cleaned the corona wire and `Drum Error` was not cleared then the drum unit is at the end of its life. Replace the drum unit with a new one.

## Replace Parts Drum



The drum unit has exceeded its rated life. Please replace the drum unit with a new one. We recommend that a Brother Original drum unit is installed at this time.

After replacement, reset the drum counter by following the instructions included with the new drum unit. (See *Resetting the drum counter* >> page 50.)

## Drum Stop



We cannot guarantee the print quality. Please replace the drum unit with a new one. We recommend that a Brother Original drum unit is installed at this time.

After replacement, reset the drum counter by following the instructions included with the new drum unit. (See *Resetting the drum counter* >> page 50.)

## Replacing the drum unit

### ! Important

- While removing the drum unit, handle it carefully because it may contain toner. If toner scatters on your hands or clothes, immediately wipe or wash it off with cold water.
- Every time you replace the drum unit, clean the inside of the machine. (See *Cleaning and Checking the machine* >> page 51.)
- Wait to unpack the new drum unit immediately before you put it in the machine. Exposure to direct sunlight or room light may damage the drum unit.

- 1 Leave the machine turned on for 10 minutes for the internal fan to cool the extremely hot parts inside the machine.
- 2 Press the front cover release button and then open the front cover.

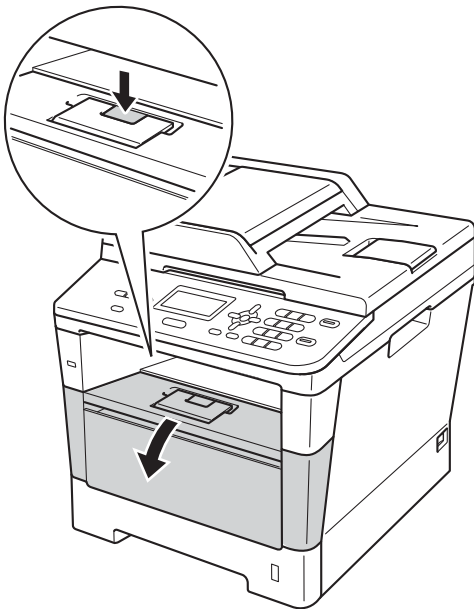

- 3 Take out the drum unit and toner cartridge assembly.

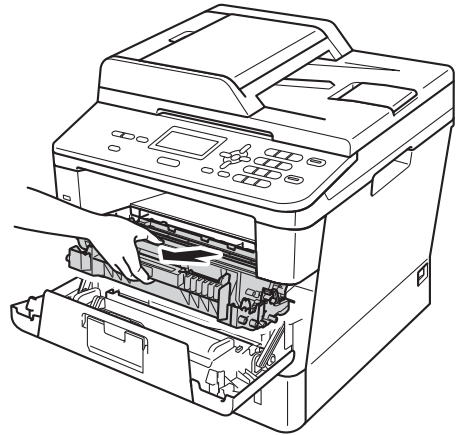

### ! WARNING

#### ! HOT SURFACE

After you have just used the machine, some internal parts of the machine will be extremely hot. Wait for the machine to cool down before you touch the internal parts of the machine.

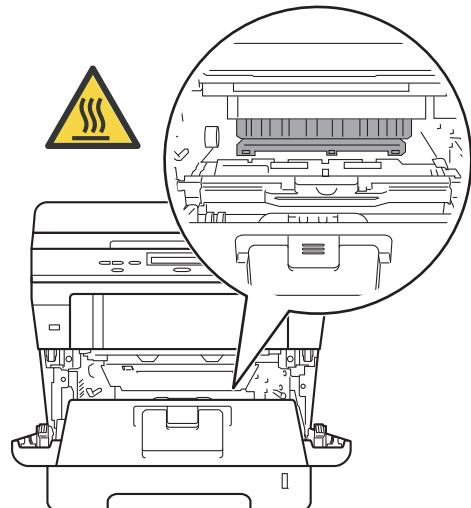

A

## ! Important

- We recommend that you place the drum unit and toner cartridge assembly on a clean, flat surface with a piece of disposable paper underneath it in case you accidentally spill or scatter toner.
- To prevent damage to the machine from static electricity, DO NOT touch the electrodes shown in the illustration.

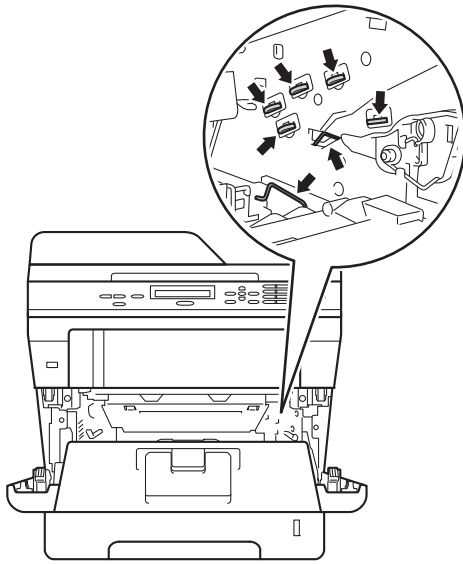

- 4 Push down the green lock lever and take the toner cartridge out of the drum unit.

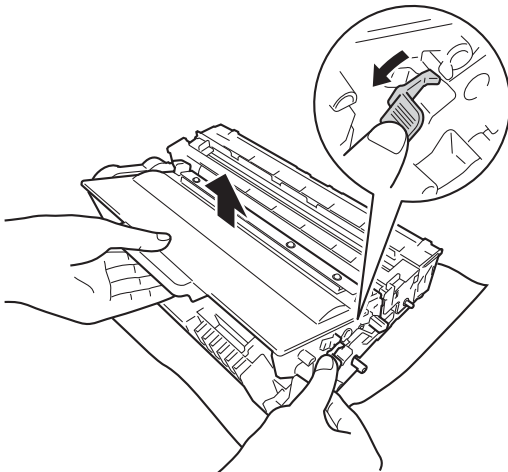

## ! WARNING



- DO NOT put a toner cartridge or a toner cartridge and drum unit assembly into a fire. It could explode, resulting in injuries.
- DO NOT use flammable substances, any type of spray, or an organic solvent/liquid containing alcohol or ammonia to clean the inside or outside of the machine. Doing so could cause a fire or electrical shock. Instead, use only a dry, lint-free cloth.

(>> Product Safety Guide: *General precautions*)





### ! Important

- Handle the toner cartridge carefully. If toner scatters on your hands or clothes, immediately wipe or wash it off with cold water.
- To avoid print quality problems, DO NOT touch the shaded parts shown in the illustrations.

#### <Toner cartridge>

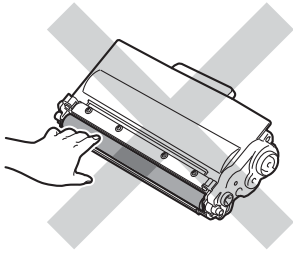

#### <Drum unit>

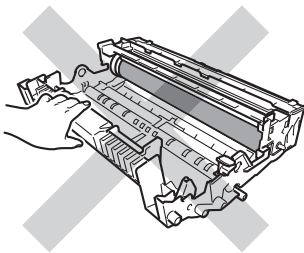

- We recommend that you place the toner cartridge on a clean, flat, level, stable surface with a sheet of disposable paper or cloth underneath it in case you accidentally spill or scatter toner.

### 📝 Note

- Be sure to seal up the used drum unit tightly in a suitable bag so that toner powder does not spill out of the drum unit.
- Go to <http://www.brother.com/original/index.html> for instructions on how to return your used items to the Brother recycling program. If you choose not to return your used items, please discard the used items according to local regulations, keeping it separate from domestic waste. If you have questions, call your local waste disposal office.

(▶▶ Product Safety Guide: *Recycling information in accordance with the WEEE (2002/96/EC) and Battery (2006/66/EC) Directives*)

5. Unpack the new drum unit.

- 6 Put the toner cartridge firmly into the new drum unit until you hear it lock into place. If you put the cartridge in correctly, the green lock lever will lift automatically.

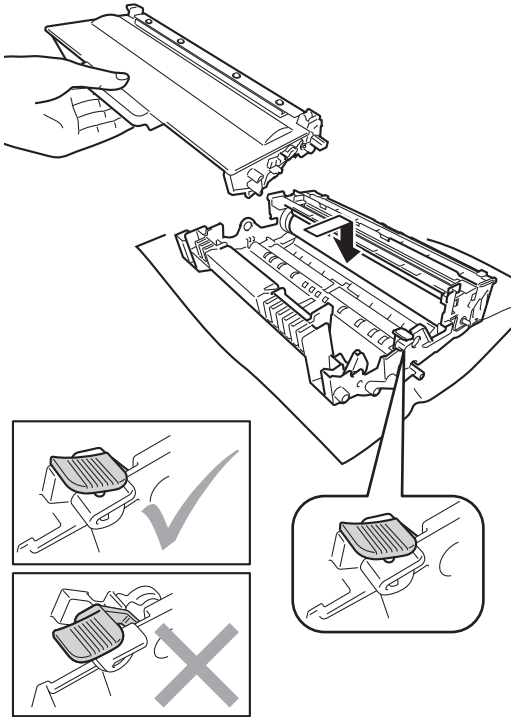

### Note

Make sure that you put in the toner cartridge correctly or it may separate from the drum unit.

- 7 Put the drum unit and toner cartridge assembly back into the machine. Do not close the front cover of the machine.

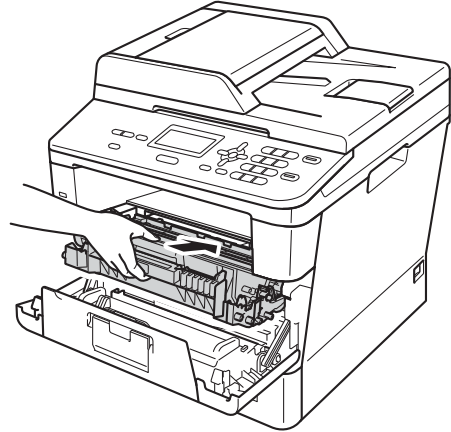

### Resetting the drum counter

When you replace a drum unit with a new one, you need to reset the drum counter by completing the following steps:

#### Important

Do not reset the drum counter when you only replace the toner cartridge.

- 1 With the front cover still open, press **Clear**.
- 2 To confirm you are installing a new drum, press **1**.
- 3 When the LCD shows *Accepted*, close the front cover of the machine.

## Cleaning and Checking the machine

Clean the outside and inside of the machine regularly with a dry, lint-free cloth. When you replace the toner cartridge or the drum unit, make sure that you clean the inside of the machine. If printed pages are stained with toner, clean the inside of the machine with a dry, lint-free cloth.

### WARNING



- DO NOT put a toner cartridge or a toner cartridge and drum unit assembly into a fire. It could explode, resulting in injuries.
- DO NOT use flammable substances, any type of spray, or an organic solvent/liquid containing alcohol or ammonia to clean the inside or outside of the machine. Doing so could cause a fire or electrical shock. Instead, use only a dry, lint-free cloth.

(>> Product Safety Guide: *General precautions*)



### Important

Use neutral detergents. Cleaning with volatile liquids such as thinner or benzine will damage the surface of the machine.

## Cleaning the outside of the machine

- 1 Turn off the machine.
- 2 Disconnect the interface cables from the machine, and then unplug the power cord from the electrical socket.
- 3 Wipe the outside of the machine with a dry, lint-free cloth to remove dust.

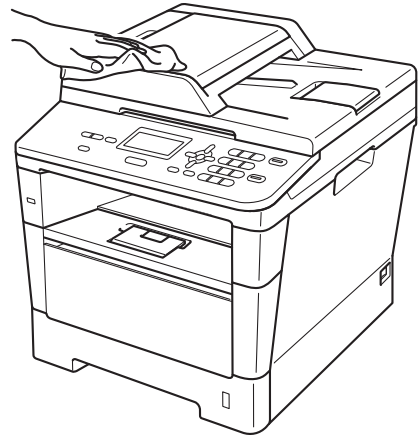

- 4 Pull the paper tray completely out of the machine.

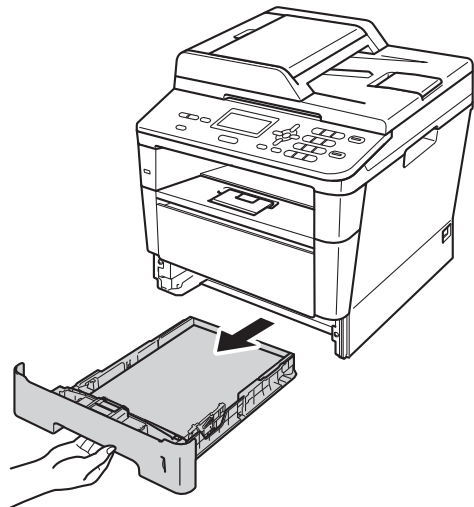

- 5 If paper is loaded in the paper tray, remove it.

6 Remove anything that is stuck inside the paper tray.

7 Wipe the inside and the outside of the paper tray with a dry, lint-free cloth to remove dust.

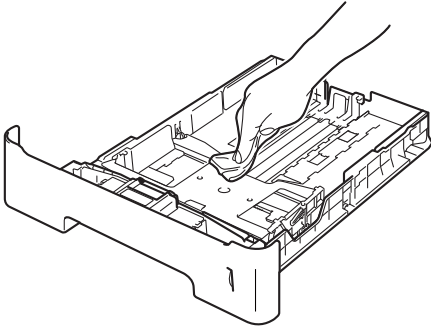

8 Re-load the paper and put the paper tray firmly back in the machine.

9 Plug the machine's power cord back into the electrical socket first, then connect all cables.

10 Turn on the machine.

## Cleaning the scanner glass

1 Turn off the machine.

2 Disconnect all cables, and then unplug the power cord from the electrical socket.

3 Lift the document cover (1). Clean the white plastic surface (2) and scanner glass (3) underneath it with a soft lint-free cloth moistened with water.

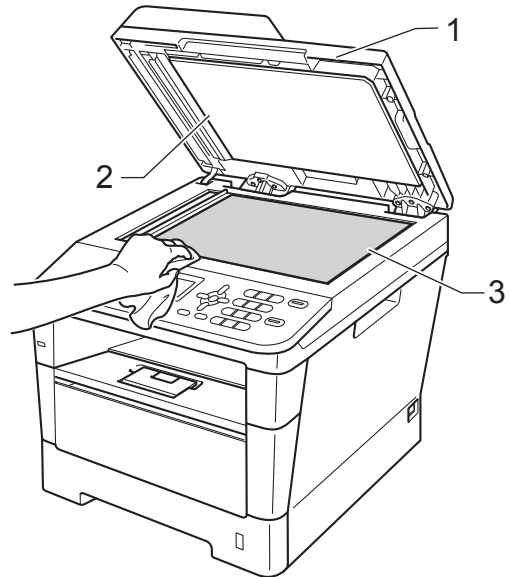

4 In the ADF unit, clean the white bar (1) and the scanner glass strip (2) underneath it with a soft lint-free cloth moistened with water.

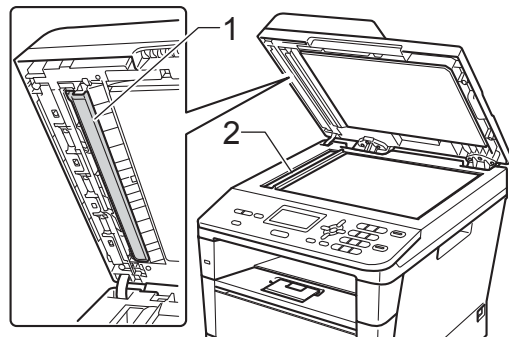

**Note**

In addition to cleaning the scanner glass and glass strip with a soft lint-free cloth moistened with water, run your finger tip over the glass to see if you can feel anything on it. If you feel dirt or debris, clean the glass again concentrating on that area. You may need to repeat the cleaning process three or four times. To test, make a copy after each cleaning.

- 5 Close the document cover.
- 6 Plug the machine's power cord back into the electrical socket first, then connect all cables.
- 7 Turn on the machine.

**Cleaning the corona wire**

If you have print quality problems or the LCD shows **Drum Error**, clean the corona wire as follows:

- 1 Leave the machine turned on for 10 minutes for the internal fan to cool the internal parts of the machine that are extremely hot.
- 2 Press the front cover release button and then open the front cover.

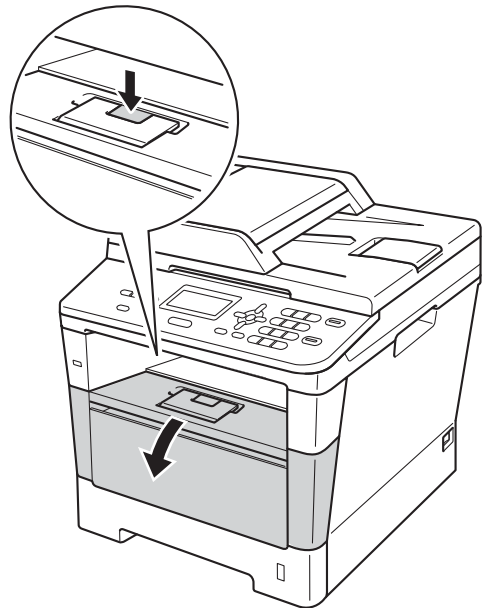

- 3 Take out the drum unit and toner cartridge assembly.

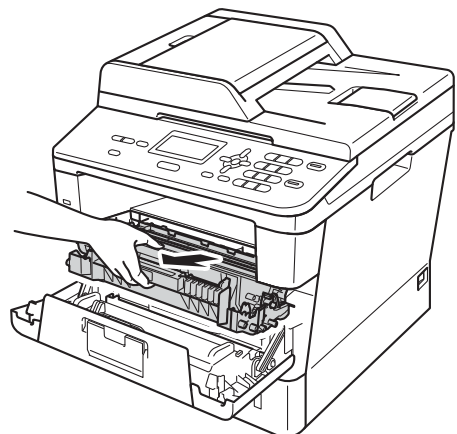

## WARNING

### HOT SURFACE

After you have just used the machine, some internal parts of the machine will be extremely hot. Wait for the machine to cool down before you touch the internal parts of the machine.

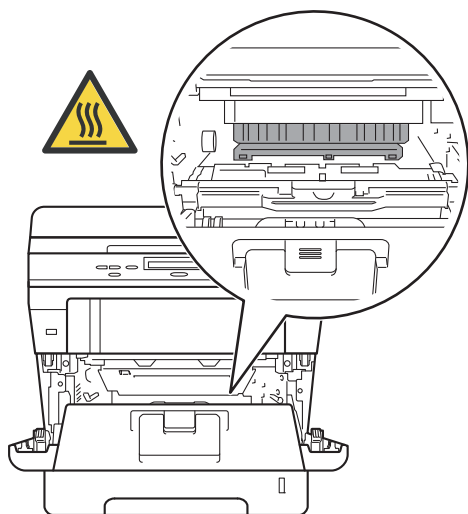

## Important

- We recommend that you put the drum unit and toner cartridge assembly on a piece of disposable paper or cloth in case you accidentally spill or scatter toner.
- Handle the drum unit and toner cartridge assembly carefully. If toner scatters on your hands or clothes, wipe or wash it off with cold water.
- To prevent damage to the machine from static electricity, **DO NOT** touch the electrodes shown in the illustration.

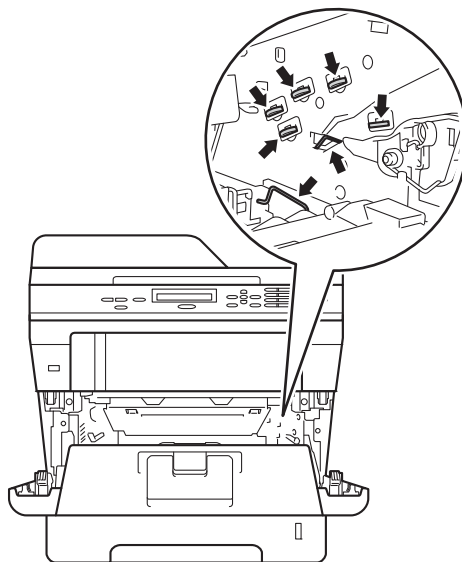

- 4 Clean the corona wire inside the drum unit by gently sliding the green tab back and forth several times.

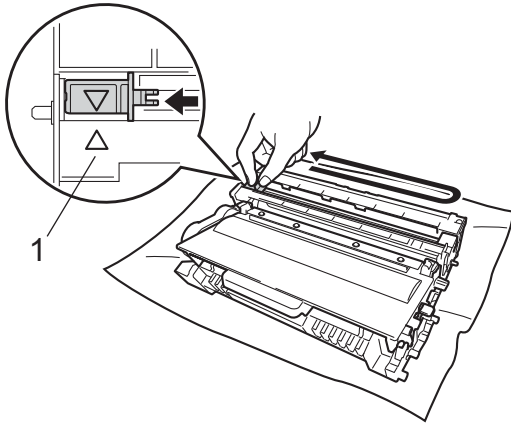

### Note

Be sure to return the tab to the home position (▲) (1). If you do not, printed pages may have a vertical stripe.

- 5 Put the drum unit and toner cartridge assembly back into the machine.

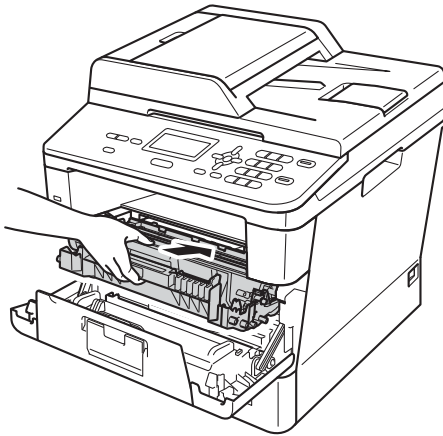

- 6 Close the front cover of the machine.

## Cleaning the drum unit

If your printout has dots at 94 mm intervals, follow the steps below to solve the problem.

- 1 Make sure that the machine is in the Ready mode. Press **Menu**, **6**, **6**, then press **Start** to print the drum dot check sheet.

|                   |
|-------------------|
| 66.Drum Dot Print |
| Printing          |

- 2 Leave the machine turned on for 10 minutes for the internal fan to cool the internal parts of the machine that are extremely hot.
- 3 After the machine has cooled down, turn off the machine.
- 4 Press the front cover release button and then open the front cover.

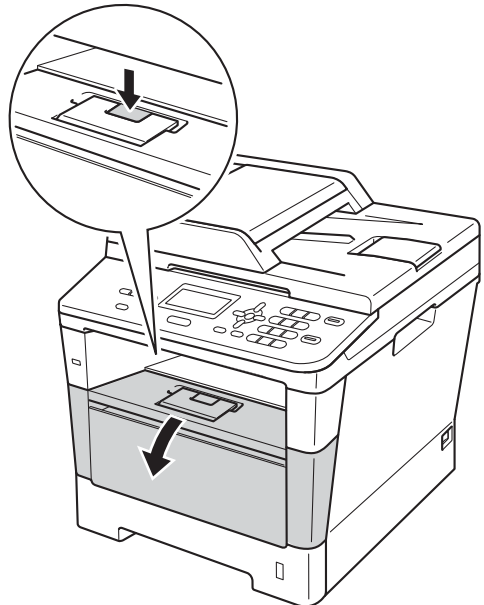

- 5 Take out the drum unit and toner cartridge assembly.

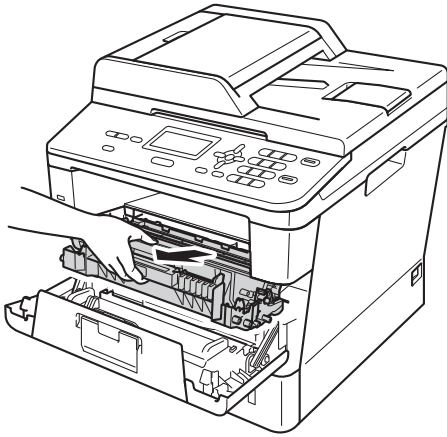

## ! WARNING

### ! HOT SURFACE

After you have just used the machine, some internal parts of the machine will be extremely hot. Wait for the machine to cool down before you touch the internal parts of the machine.

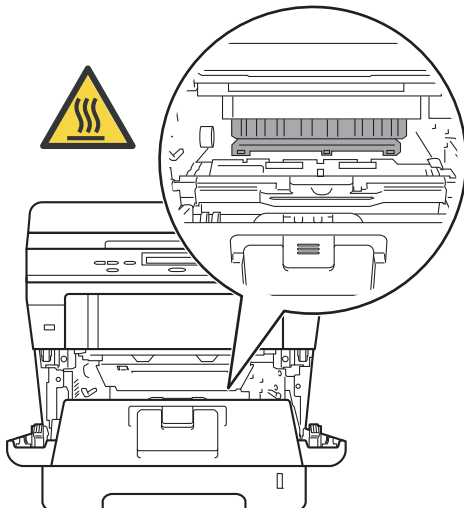

## ! Important

- We recommend that you put the drum unit and toner cartridge assembly on a piece of disposable paper or cloth in case you accidentally spill or scatter toner.
- Handle the drum unit and toner cartridge assembly carefully. If toner scatters on your hands or clothes, wipe or wash it off with cold water.
- To prevent damage to the machine from static electricity, DO NOT touch the electrodes shown in the illustration.

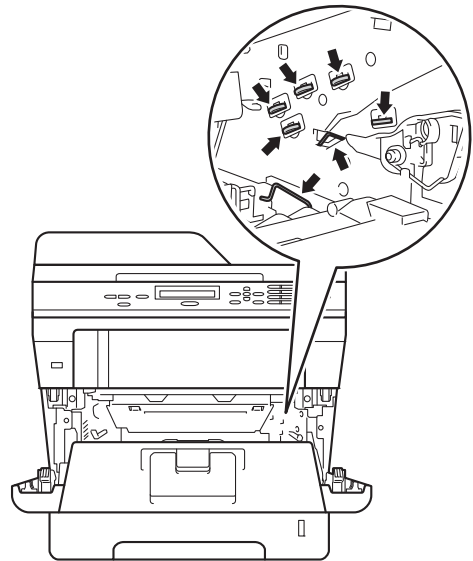



- 6 Push down the green lock lever and take the toner cartridge out of the drum unit.

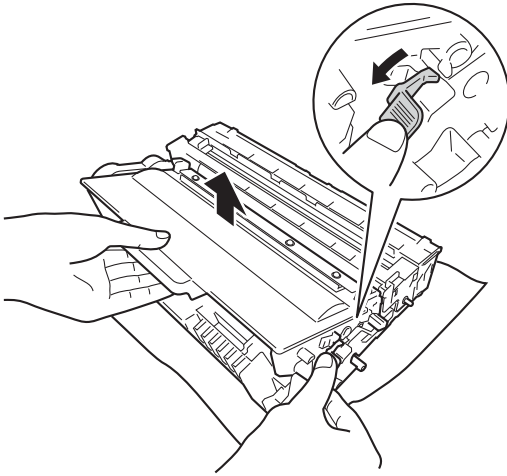

- 7 Turn the drum unit as shown in the illustration. Make sure that the drum unit gear (1) is on the left hand side.

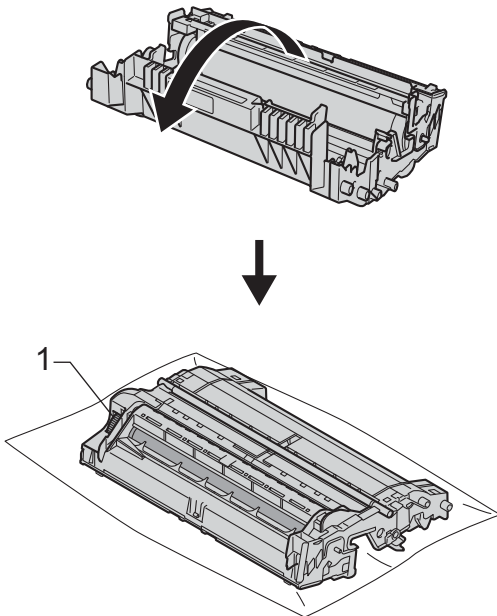

- 8 Use the numbered markers next to the drum roller to find the mark. For example, a dot in column 2 on the check sheet would mean that there is a mark in the "2" region of the drum.

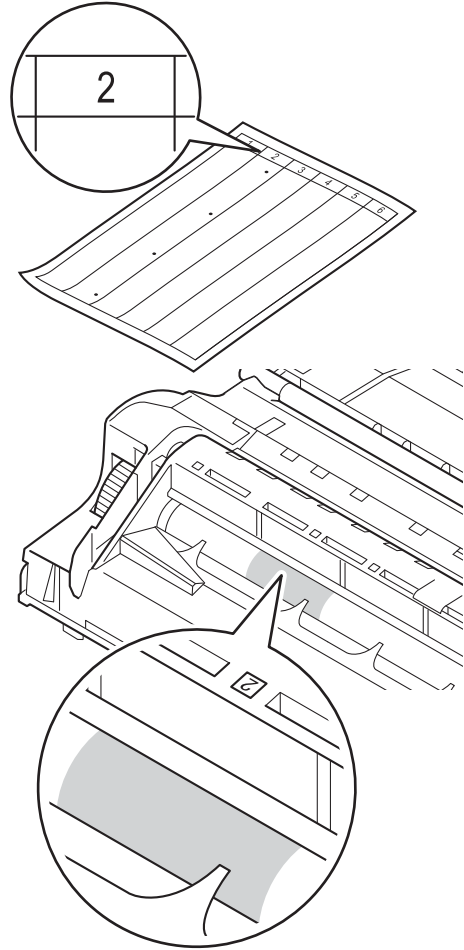

- 9 Turn the drum unit gear toward you by hand while checking the surface of the suspected area.

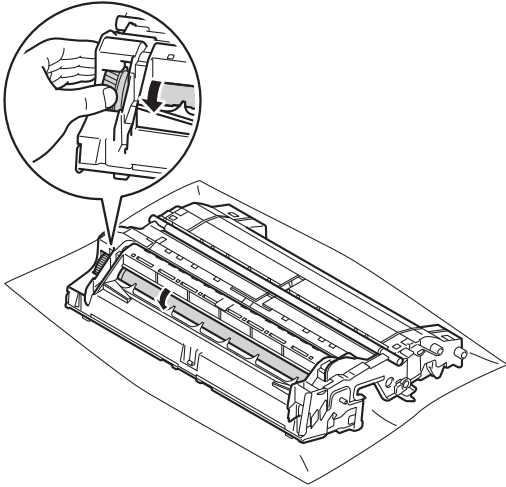

- 10 When you have found the mark on the drum that matches the drum dot check sheet, wipe the surface of the drum gently with a dry cotton swab until the mark on the surface comes off.

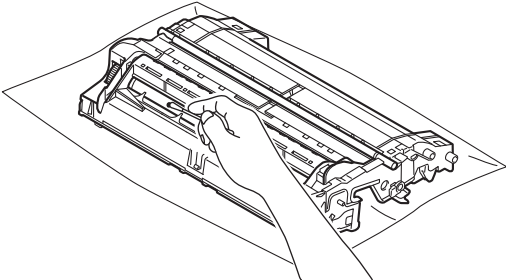

**Important**

DO NOT clean the surface of the photosensitive drum with a sharp object or any liquids.

- 11 Turn the drum unit back over.

- 12 Put the toner cartridge back into the drum unit until you hear it lock into place. If you put the cartridge in correctly, the green lock lever on the drum unit will lift automatically.

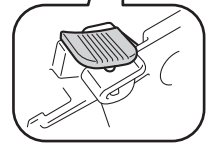
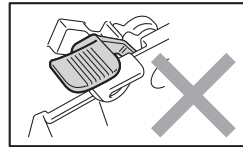
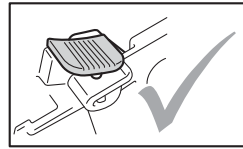
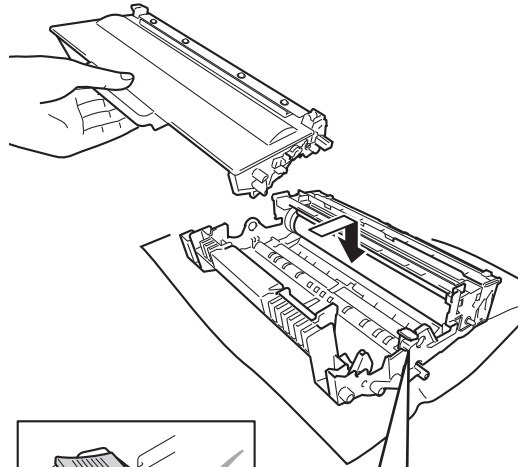

**Note**

Make sure that you put in the toner cartridge correctly or it may separate from the drum unit.

- 13 Put the drum unit and toner cartridge assembly back into the machine.

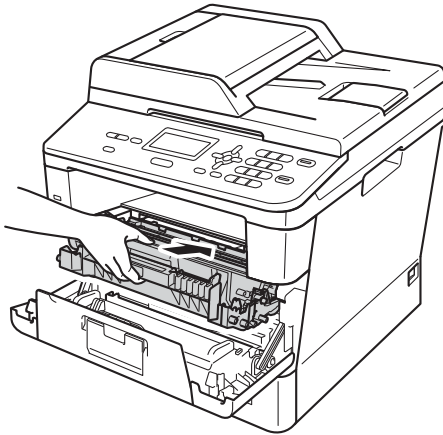

- 14 Close the front cover of the machine.
- 15 Turn on the machine and try a test print.

## Cleaning the paper pick-up rollers

Cleaning the paper pick-up roller periodically may prevent paper jams by ensuring the correct feeding of the paper.

If you have paper feed problems, clean the pick-up rollers as follows:

- 1 Turn off the machine.
- 2 Disconnect all cables, and then unplug the power cord from the electrical socket.
- 3 Pull the paper tray completely out of the machine.

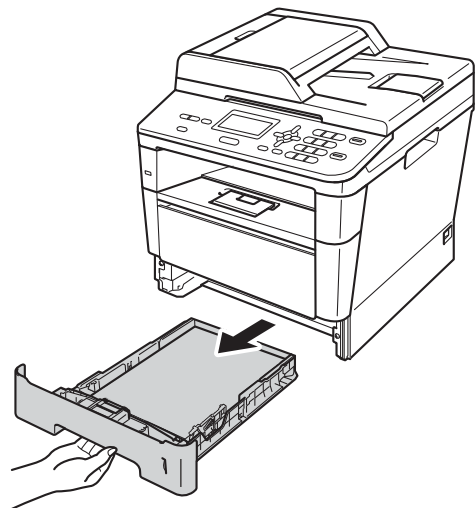

- 4 Tightly wring out a lint-free cloth soaked in lukewarm water, and then wipe the separator pad (1) on the paper tray to remove dust.

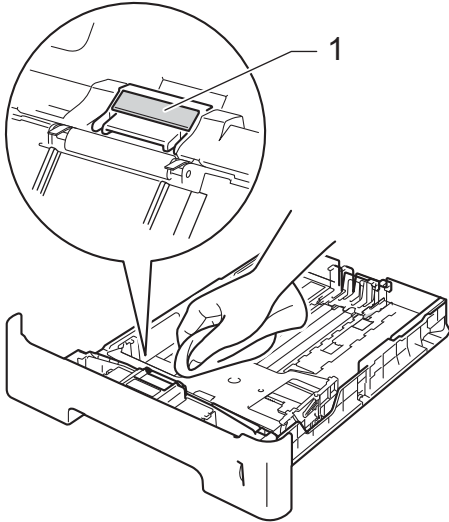

- 5 Wipe the two pick-up rollers (1) inside the machine to remove dust.

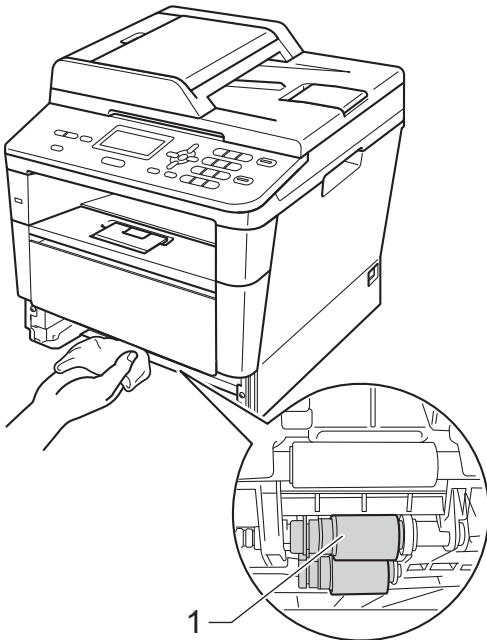

- 6 Put the paper tray back in the machine.

- 7 Plug the machine's power cord back into the electrical socket.

- 8 Turn on the machine.

If you think there is a problem with your machine, check each of the items below first and then follow the troubleshooting tips.

You can correct most problems by yourself. If you need additional help, the Brother Solutions Center offers the latest FAQs and troubleshooting tips.

Visit us at <http://solutions.brother.com/>.

## Identifying your problem

First, check the following:

- The machine's power cord is connected correctly and the machine's power switch is turned on. If the machine does not turn on after connecting the power cord, see *Other difficulties* >> page 86.
- All of the protective parts have been removed.
- Paper is inserted correctly in the paper tray.
- The interface cables are securely connected to the machine and the computer.
- LCD Messages  
(See *Error and maintenance messages* >> page 62)

If you did not solve the problem with the above checks, identify your problem and then go to the page suggested below.

Paper handling and Printing problems:

- *Printing difficulties* >> page 81
- *Paper handling difficulties* >> page 83

Copying problems:

- *Copying difficulties* >> page 84

Scanning problems:

- *Scanning difficulties* >> page 84

Software and Network problems:

- *Software difficulties* >> page 84
- *Network difficulties* >> page 85

## Error and maintenance messages

As with any sophisticated office product, errors may occur and consumable items may need to be replaced. If this happens, your machine identifies the error or required routine maintenance and shows the appropriate message. The most common error and maintenance messages are shown below.

You can clear most errors and perform routine maintenance by yourself. If you need more help, the Brother Solutions Center offers the latest FAQs and troubleshooting tips:

Visit us at <http://solutions.brother.com/>.

| Error Message                                       | Cause   | Action  |
|---|---|---|
| Access Denied                                       | The function you want to use is restricted by Secure Function Lock 2.0.   | Contact your administrator to check your Secure Function Lock Settings.   |
| Access Error  | The device is removed from the USB direct interface while the data is processing.   | Press <b>Stop/Exit</b> . Reinsert the device and try to print with Direct Print.  |
| Cartridge Error<br>Put the Toner Cartridge back in. | The toner cartridge is not installed correctly.   | Pull out the drum unit and toner cartridge assembly, take out the toner cartridge, and put it back into the drum unit again. Put the drum unit and toner cartridge assembly back in the machine.  |
| Cooling Down<br>Wait for a while                    | The temperature of the drum unit or toner cartridge is too hot. The machine will pause its current print job and go into cooling down mode. During the cooling down mode, you will hear the cooling fan running while the LCD shows <b>Cooling Down, and Wait for a while</b> . | Make sure that you can hear the fan in the machine spinning and that the exhaust outlet is not blocked by something.<br><br>If the fan is spinning, remove any obstacles that surround the exhaust outlet, and then leave the machine turned on but do not use it for several minutes.<br><br>If the fan is not spinning, disconnect the machine from the power for several minutes, then reconnect it. |
| Cover is Open                                       | The front cover is not completely closed.   | Close the front cover of the machine.   |
|   | The ADF cover is not completely closed.   | Close the ADF cover of the machine.   |
|   | The ADF is open while loading a document.   | Close the ADF cover of the machine, then press <b>Stop/Exit</b> .   |
|   | The fuser cover is not completely closed or paper was jammed in the back of the machine when you turned on the power.   | <ul style="list-style-type: none"> <li>■ Close the fuser cover of the machine.</li> <li>■ Make sure paper is not jammed behind the fuser cover at the back of the machine, then close the fuser cover and press <b>Start</b>.</li> </ul> <p>(See <i>Paper is jammed at the back of the machine</i> ►► page 72.)</p>   |

| Error Message   | Cause  | Action   |
|-----------------|--|--|
| DIMM Error      | <ul style="list-style-type: none"> <li>■ The DIMM is not installed correctly.</li> <li>■ The DIMM is broken.</li> <li>■ The DIMM does not meet the required specifications.</li> </ul> | <ul style="list-style-type: none"> <li>■ Turn off the machine and remove the DIMM.<br/>(&gt;&gt; Advanced User's Guide: <i>Installing extra memory</i>)</li> <li>■ Confirm the DIMM meets the required specifications.<br/>(&gt;&gt; Advanced User's Guide: <i>Memory board</i>)</li> <li>■ Re-install the DIMM correctly. Wait a few seconds, and then turn it on again.</li> <li>■ If this error message appears again, replace the DIMM with a new one.<br/>(&gt;&gt; Advanced User's Guide: <i>Installing extra memory</i>)</li> </ul> |
| Document Jam    | The document was not inserted or fed correctly, or the document scanned from the ADF was too long.   | See <i>Document is jammed in the top of the ADF unit</i> >> page 68 or <i>Using the automatic document feeder (ADF)</i> >> page 24.  |
| Drum Error      | The corona wire on the drum unit needs to be cleaned.  | Clean the corona wire on the drum unit.<br>(See <i>Cleaning the corona wire</i> >> page 53.)   |
|                 | The toner cartridge is placed in the machine without the drum unit.  | Put the toner cartridge into the drum unit, and then re-install the drum unit and toner cartridge assembly in the machine.   |
| Drum Stop       | It is time to replace the drum unit.   | Replace the drum unit.<br>(See <i>Replacing the drum unit</i> >> page 47.)   |
| Duplex Disabled | The back cover of the machine is not closed completely.  | Close the back cover of the machine.   |
| Fuser Error     | The temperature of the fuser unit does not rise to a specified temperature within the specified time.  | Turn the power switch off, wait a few seconds, and then turn it on again. Leave the machine idle for 15 minutes with the power on.   |
|                 | The fuser unit is too hot.   |  |
| Jam Duplex      | The paper is jammed in the duplex tray or the fuser unit.  | See <i>Paper is jammed in the duplex tray</i> >> page 79.  |
| Jam Inside      | The paper is jammed inside the machine.  | See <i>Paper is jammed inside the machine</i> >> page 75.  |
|                 | The toner cartridge is placed in the machine without the drum unit.  | Put the toner cartridge into the drum unit, and then re-install the drum unit and toner cartridge assembly in the machine.   |
| Jam MP Tray     | The paper is jammed in the MP tray of the machine.   | See <i>Paper is jammed in the MP tray</i> >> page 70.  |
| Jam Rear        | The paper is jammed in the back of the machine.  | See <i>Paper is jammed at the back of the machine</i> >> page 72.  |

| Error Message            | Cause   | Action  |
|--------------------------|---|---|
| Jam Tray 1<br>Jam Tray 2 | The paper is jammed in the paper tray of the machine.   | See <i>Paper is jammed in paper tray 1 or tray 2</i> >> page 71.  |
| Limit Exceeded           | The number of pages you are allowed to print has been exceeded. The print job will be cancelled.                    | Contact your administrator to check your Secure Function Lock Settings.   |
| Log Access Error         | The machine could not access the print log file in the server.  | Contact your administrator to check the Store Print Log to Network settings.<br>For detailed information >> Network User's Guide: <i>Store Print Log to Network</i>   |
| Manual Feed              | <b>Manual</b> was selected as the paper source when there was no paper in the MP tray.                              | Place paper in the MP tray. If the machine is in Pause mode, press <b>Start</b> . (See <i>Loading paper in the multi-purpose tray (MP tray)</i> >> page 12)   |
| No HUB Support           | A USB hub device is connected to the USB direct interface.  | Disconnect the USB hub device from the USB direct interface.  |
| No Paper                 | The machine is out of paper in the specified tray or all trays, or paper is not correctly loaded in the paper tray. | Do one of the following: <ul style="list-style-type: none"> <li>■ Refill paper in the paper tray shown on the LCD. Make sure the paper guides are set to the correct size.</li> <li>■ Remove the paper and load it again. Make sure the paper guides are set to the correct size.</li> </ul>  |
| No Toner                 | The toner cartridge or the drum unit and toner cartridge assembly is not installed correctly.                       | Remove the drum unit and toner cartridge assembly, remove the toner cartridge from the drum unit, and re-install the toner cartridge back into the drum unit again. Re-install the drum unit and toner cartridge assembly back in the machine. If the problem continues, replace the toner cartridge.<br><br>(See <i>Replacing the toner cartridge</i> >> page 40.) |
| No Tray                  | The standard paper tray is not installed or not installed correctly.  | Re-install the standard paper tray.   |
| Not Available            | The requested function is not permitted to all User IDs by Secure Function Lock 2.0.                                | Contact your administrator to check your Secure Function Lock Settings.   |



| Error Message                               | Cause  | Action   |
|---|--|--|
| Out of Memory                               | The machine's memory is full.  | <p><b>Copy operation in process</b></p> <p>Do one of the following:</p> <ul style="list-style-type: none"> <li>■ Press <b>Start</b> to copy the scanned pages.</li> <li>■ Press <b>Stop/Exit</b> and wait until the other operations in progress finish, and then try again.</li> <li>■ Add optional memory.</li> </ul> <p>(&gt;&gt; Advanced User's Guide: <i>Memory board</i>)</p> <p><b>Print operation in process</b></p> <p>Do one of the following:</p> <ul style="list-style-type: none"> <li>■ Reduce the print resolution.</li> </ul> <p>(&gt;&gt; Software User's Guide: <i>Printing</i> (for Windows®) or <i>Printing and Faxing</i> (for Macintosh))</p> <ul style="list-style-type: none"> <li>■ Add optional memory.</li> </ul> <p>(&gt;&gt; Advanced User's Guide: <i>Memory board</i>)</p> |
| Out of Memory<br>Secure Print Data is full. | The machine's memory is full.  | <p>Press <b>Stop/Exit</b> and delete the previously stored secure print data.</p> <p>(&gt;&gt; Software User's Guide: <i>Secure Print Key</i>)</p>   |
| Print Unable XX                             | The machine has a mechanical problem.  | <p>Do one of the following:</p> <ul style="list-style-type: none"> <li>■ Turn the power switch off, wait a few minutes, and then turn it on again.</li> <li>■ If the problem continues, call Brother customer service for support.</li> </ul>  |
| Protected Device                            | The protect switch of the USB Flash memory drive is on.  | Turn off the protect switch of the USB Flash memory drive.   |
| Rename the File                             | There is already a file on the USB Flash memory drive with the same name as the file you are trying to save. | Change the file name of the file on the USB Flash memory drive or the file you are trying to save.   |
| Replace Parts<br>Drum                       | It is time to replace the drum unit.   | Replace the drum unit.<br>(See <i>Replacing the drum unit</i> >>> page 47.)  |
|   | The drum unit counter was not reset when a new drum was installed.   | Reset the drum unit counter.<br>(See <i>Resetting the drum counter</i> >>> page 50.)   |
| Replace Parts<br>Fuser Unit                 | It is time to replace the fuser unit.  | Call Brother customer service or a Brother Authorized Service Center to replace the fuser unit.  |

| Error Message   | Cause  | Action  |
|---|--|---|
| Replace Parts<br>Laser Unit   | It is time to replace the laser unit.  | Call Brother customer service or a Brother Authorized Service Center to replace the laser unit.   |
| Replace Parts<br>PF Kit 1<br>PF Kit 2<br>PF Kit MP                          | It is time to replace the paper feeding kit.   | Call Brother customer service or a Brother Authorized Service Center to replace the PF Kit.   |
| Replace Toner   | The toner cartridge is at the end of its life. The machine will stop all print operations.   | Replace the toner cartridge.<br>(See <i>Replacing the toner cartridge</i> >> page 40.)  |
| Scan Unable XX  | The machine has a mechanical problem.  | <ul style="list-style-type: none"> <li>■ Turn the power switch off, and then turn it on again.</li> <li>■ If the problem continues, call Brother customer service for support.</li> </ul> |
| Size Error  | The paper size defined in the printer driver is not suitable for the tray in use.  | Choose a paper size which is supported by the tray shown on the LCD.<br>(See <i>Paper Size</i> >> page 17.)   |
| Size Error DX   | The paper size defined in the printer driver and the control panel menu is not suitable for automatic duplex printing.                           | Press <b>Stop/Exit</b> . Choose a paper size which is supported by the duplex tray.<br>The paper size you can use for automatic duplex printing is A4.                                    |
|   | The paper in the tray is not the correct size and is not suitable for automatic duplex printing.   | Press <b>Start</b> . Load the correct size of paper in the tray and set the "Paper Size" ( <b>Menu, 1, 1, 2</b> ).<br>The paper size you can use for automatic duplex printing is A4.     |
| Size mismatch   | The paper in the tray is not the correct size.   | Load the correct size of paper in the tray and set the "Paper Size" ( <b>Menu, 1, 1, 2</b> ).<br>(See <i>Paper Size</i> >> page 17.)  |
| Toner Low   | If the LCD shows <b>Toner Low</b> you can still print; however, the machine is telling you that the toner cartridge is near the end of its life. | Order a new toner cartridge now so a replacement toner cartridge will be available when the LCD shows <b>Replace Toner</b> .  |
| Too Many Files  | There are too many files stored on the USB Flash memory drive.   | Reduce the number of files stored on the USB Flash memory drive.  |
| Unusable Device<br>Remove the Device. Turn the power off and back on again. | A defective USB device or a high power consumption USB device has been connected to the USB direct interface.                                    | Unplug the device from the USB direct interface. Turn the machine off and then on again.  |

| Error Message    | Cause  | Action  |
|------------------|--|---|
| Unusable Device  | A USB device or USB Flash memory drive that is not supported/is encrypted has been connected to the USB direct interface.                      | <p>Unplug the device from the USB direct interface.</p> <p>See the specifications for supported USB Flash memory drives in <i>Printing data from a USB Flash memory drive or digital camera supporting mass storage</i> &gt;&gt; page 27.</p> |
| Wrong Paper Size | The machine cannot find paper of the same size in any other tray after the tray currently in use has run out of paper during a copy operation. | Load the paper in the paper tray shown on the LCD.  |

## Document Jams

### Document is jammed in the top of the ADF unit

---

- 1 Take out any paper from the ADF that is not jammed.
- 2 Open the ADF cover.
- 3 Pull the jammed document out to the left.

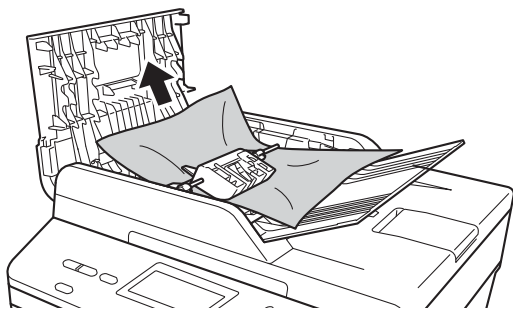

If the document rips or tears, be sure you remove all small paper scraps to prevent future jams.

- 4 Close the ADF cover.
- 5 Press **Stop/Exit**.

### Document is jammed under the document cover

---

- 1 Take out any paper from the ADF that is not jammed.
- 2 Lift the document cover.
- 3 Pull the jammed document out to the right.

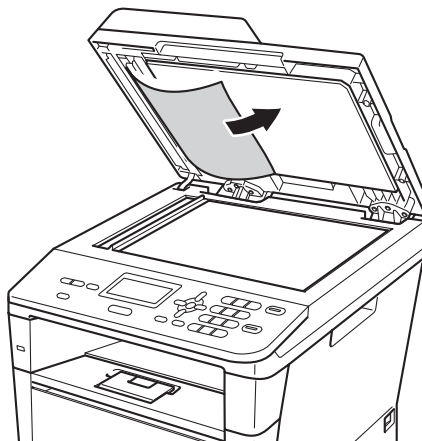

If the document rips or tears, be sure you remove all small paper scraps to prevent future jams.

- 4 Close the document cover.
- 5 Press **Stop/Exit**.

## Removing small documents jammed in the ADF

- 1 Lift the document cover.
- 2 Insert a piece of stiff paper, such as cardstock, into the ADF to push any small paper scraps through.

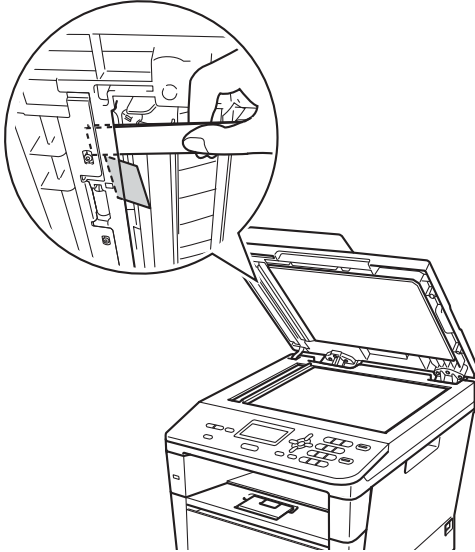

- 3 Close the document cover.
- 4 Press **Stop/Exit**.

## Document is jammed at the output tray

- 1 Take out any paper from the ADF that is not jammed.
- 2 Pull the jammed document out to the right.



- 3 Press **Stop/Exit**.

## Paper Jams

Always remove all paper from the paper tray and straighten the stack when you add new paper. This helps prevent paper jams and multiple sheets of paper from feeding through the machine at the same time.

### Paper is jammed in the MP tray

If the LCD shows **Jam MP Tray**, follow these steps:

- 1 Remove the paper from the MP tray.
- 2 Remove any jammed paper from in and around the MP tray.

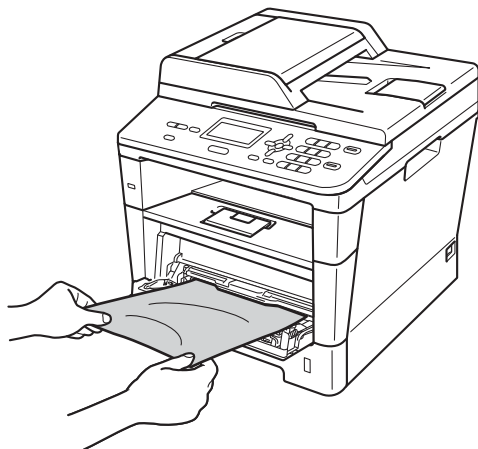

- 3 Fan the paper stack, and then put it back in the MP tray.

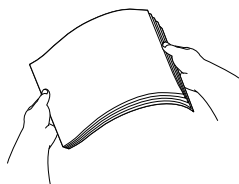

- 4 When loading paper in the MP tray, make sure that the paper stays under the maximum paper height guides (1) on both sides of the tray.

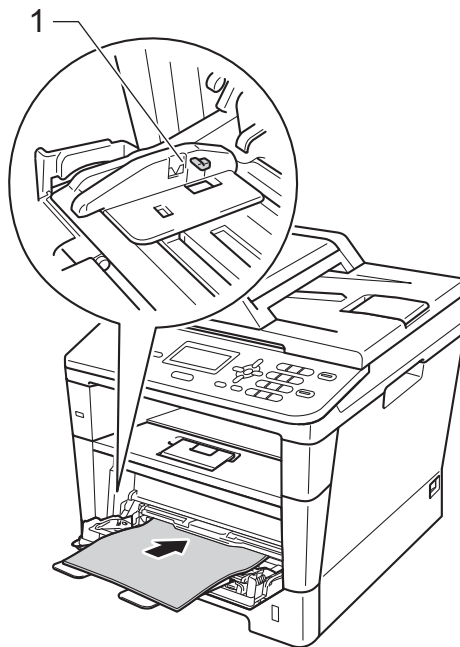

- 5 Press **Start** to resume printing.

## Paper is jammed in paper tray 1 or tray 2

If the LCD shows Jam Tray 1 or Jam Tray 2, follow these steps:

- 1 Pull the paper tray completely out of the machine.

For Jam Tray 1:



For Jam Tray 2:

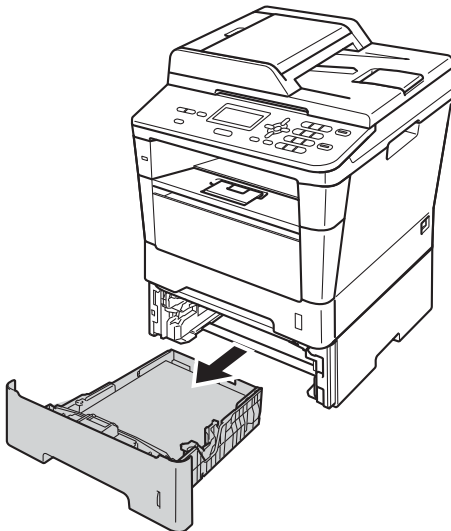

- 2 Use both hands to slowly pull out the jammed paper.

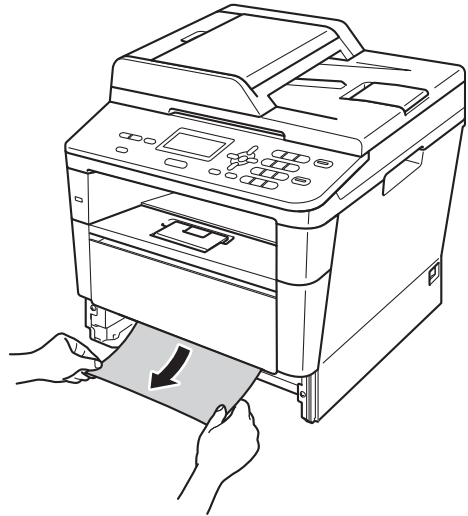

### Note

Pulling the jammed paper downward allows you to remove the paper easier.

- 3 Make sure that the paper is below the maximum paper mark (▼▼▼) in the paper tray. While pressing the green paper-guide release lever, slide the paper guides to fit the paper size. Make sure that the guides are firmly in the slots.
- 4 Put the paper tray firmly back in the machine.

## Paper is jammed at the back of the machine

If the LCD shows **Jam Rear**, a paper jam has occurred behind the back cover. Follow these steps:

- 1 Leave the machine turned on for 10 minutes for the internal fan to cool the extremely hot parts inside the machine.
- 2 Press the front cover release button and then open the front cover.

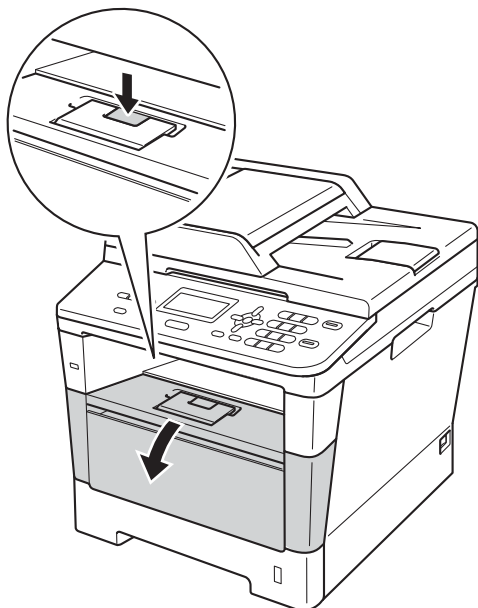

- 3 Slowly take out the drum unit and toner cartridge assembly. The jammed paper may be pulled out with the drum unit and toner cartridge assembly, or this may release the paper so you can pull it out from inside of the machine.

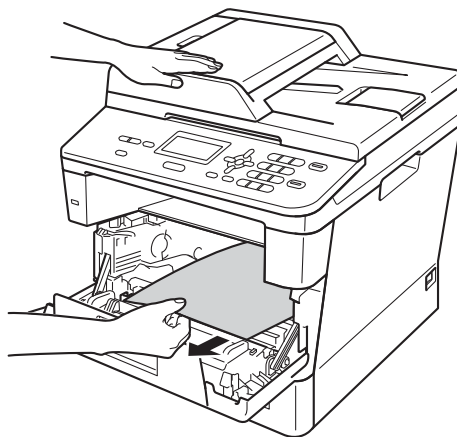
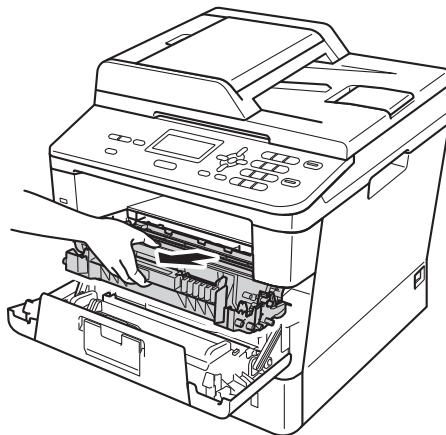



**! WARNING**

**! HOT SURFACE**

After you have just used the machine, some internal parts of the machine will be extremely hot. Wait for the machine to cool down before you touch the internal parts of the machine.

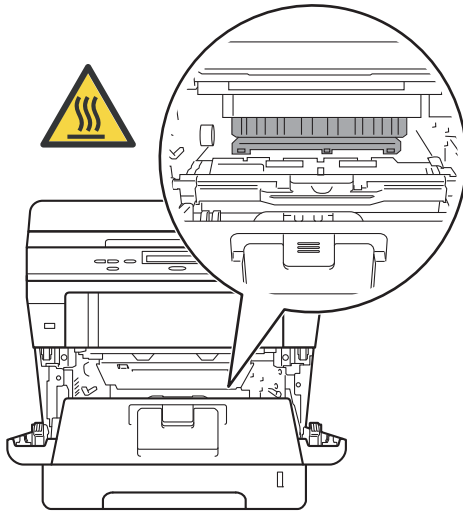

**! Important**

- We recommend that you put the drum unit and toner cartridge assembly on a piece of disposable paper or cloth in case you accidentally spill or scatter toner.
- Handle the drum unit and toner cartridge assembly carefully. If toner scatters on your hands or clothes, immediately wipe or wash it off with cold water.
- To prevent damage to the machine from static electricity, **DO NOT** touch the electrodes shown in the illustration.

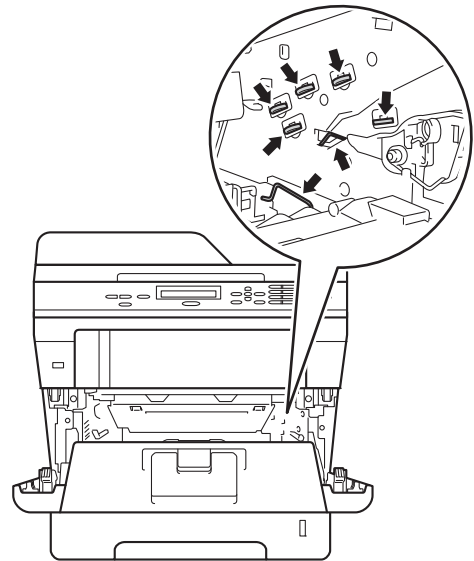

B

- 4 Open the back cover.

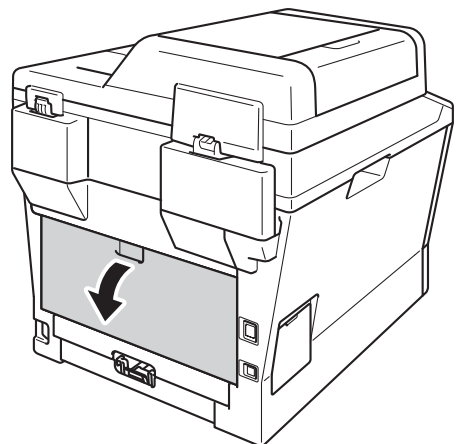

## WARNING

### HOT SURFACE

After you have just used the machine, some internal parts of the machine will be extremely hot. Wait for the machine to cool down before you touch the internal parts of the machine.

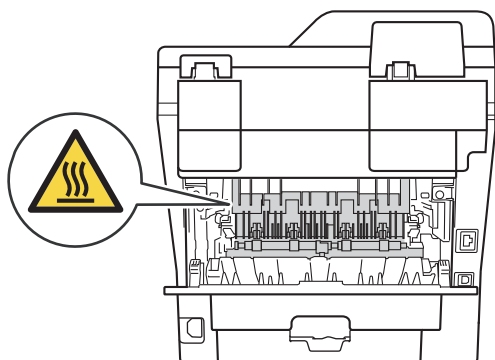

- 5 Pull the green tabs at the left and right hand sides toward you and fold down the fuser cover (1).

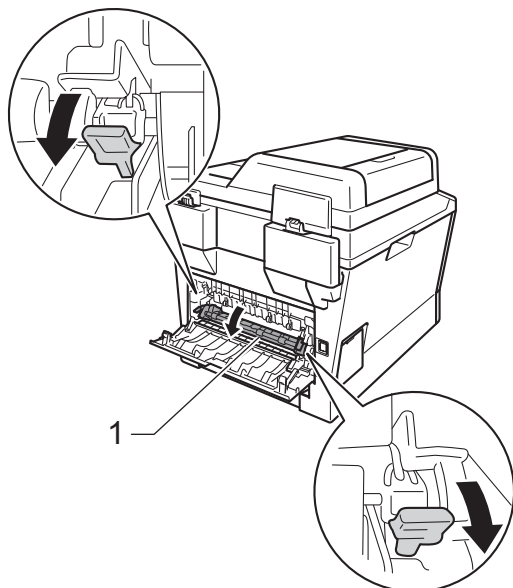

- 6 Using both hands, gently pull the jammed paper out of the fuser unit.

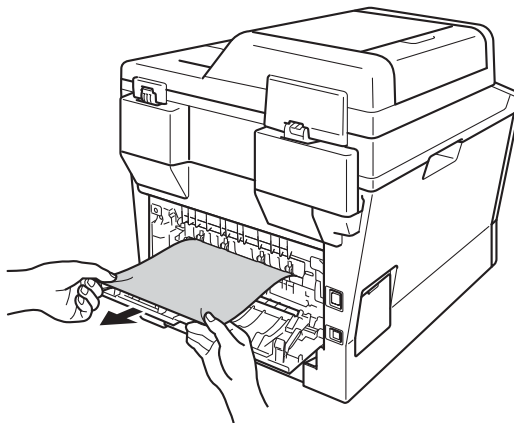

- 7 Close the fuser cover (1).

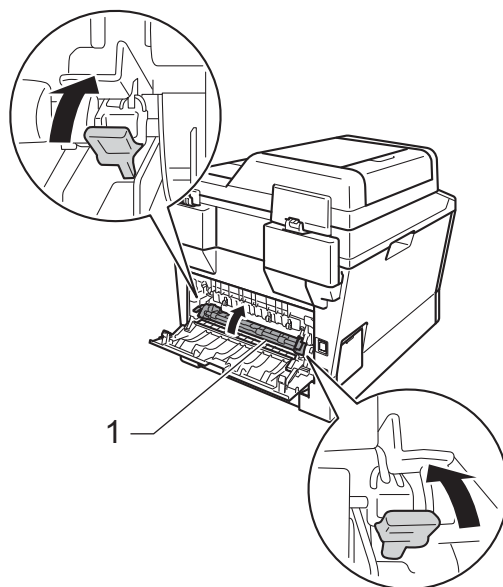

- 8 Close the back cover.

- Put the drum unit and toner cartridge assembly back into the machine.

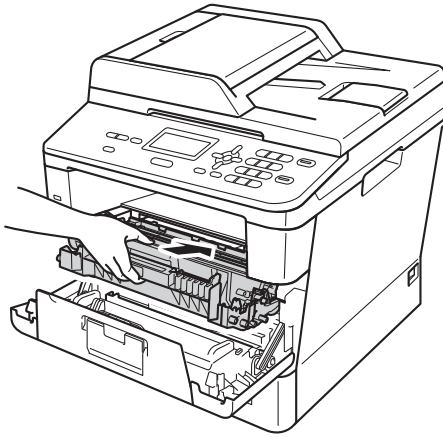

- Close the front cover of the machine.

## Paper is jammed inside the machine

If the LCD shows **Jam Inside**, follow these steps:

- Leave the machine turned on for 10 minutes for the internal fan to cool the extremely hot parts inside the machine.
- Pull the paper tray completely out of the machine.

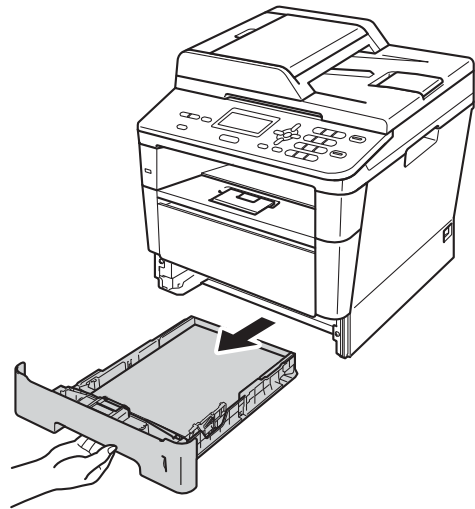

- 3 Use both hands to slowly pull out the jammed paper.

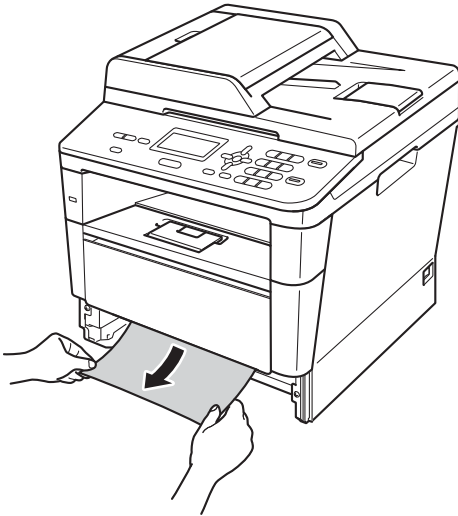

**Note**

Pulling the jammed paper downward allows you to remove the paper easier.

- 4 Press the front cover release button and then open the front cover.

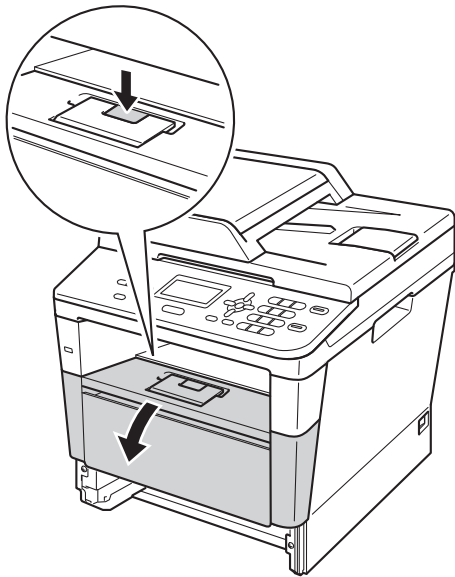

- 5 Slowly take out the drum unit and toner cartridge assembly. The jammed paper may be pulled out with the drum unit and toner cartridge assembly, or this may release the paper so you can pull it out from inside of the machine.

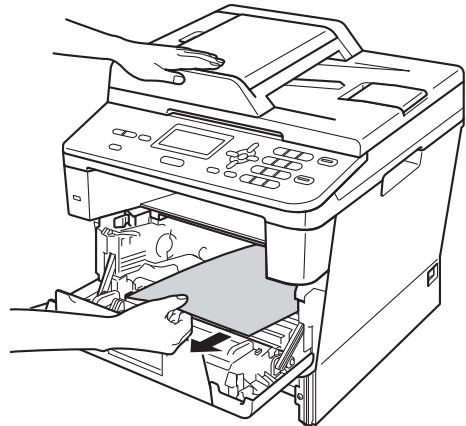
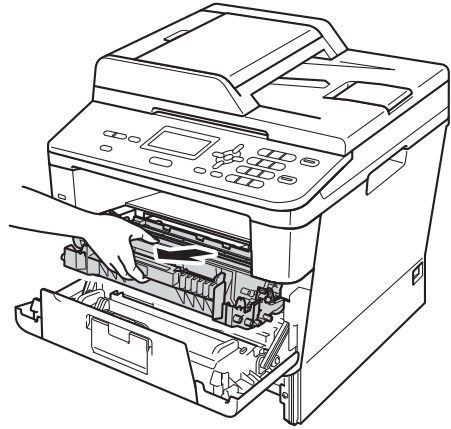

**! WARNING**

**! HOT SURFACE**

After you have just used the machine, some internal parts of the machine will be extremely hot. Wait for the machine to cool down before you touch the internal parts of the machine.

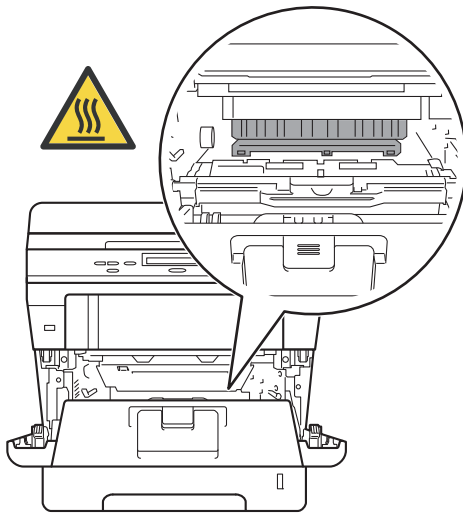

**! Important**

- We recommend that you put the drum unit and toner cartridge assembly on a piece of disposable paper or cloth in case you accidentally spill or scatter toner.
- Handle the drum unit and toner cartridge assembly carefully. If toner scatters on your hands or clothes, immediately wipe or wash it off with cold water.
- To prevent damage to the machine from static electricity, **DO NOT** touch the electrodes shown in the illustration.

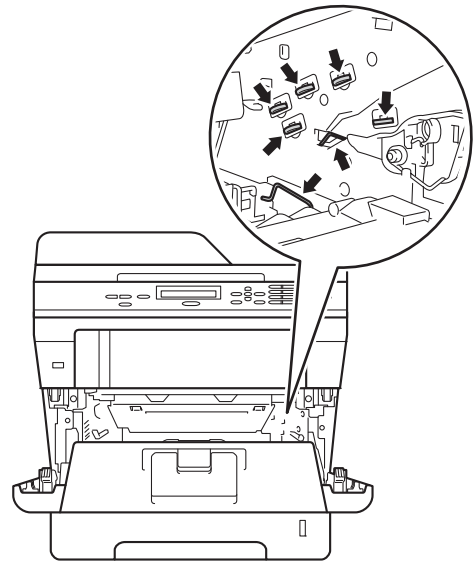

- 6 Push down the green lock lever and take the toner cartridge out of the drum unit. Remove the jammed paper if there is any inside the drum unit.

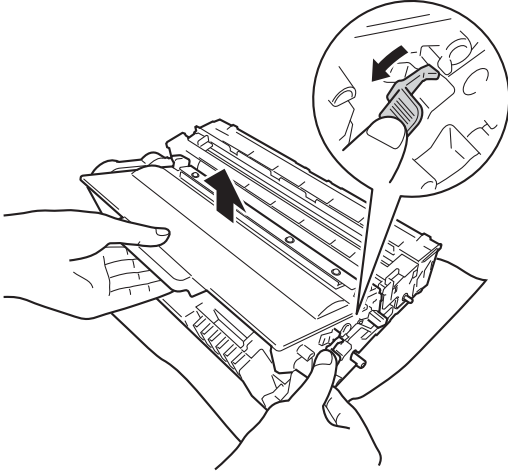

- 7 Put the toner cartridge back into the drum unit until you hear it lock into place. If you have put the cartridge in correctly, the green lock lever will lift automatically.

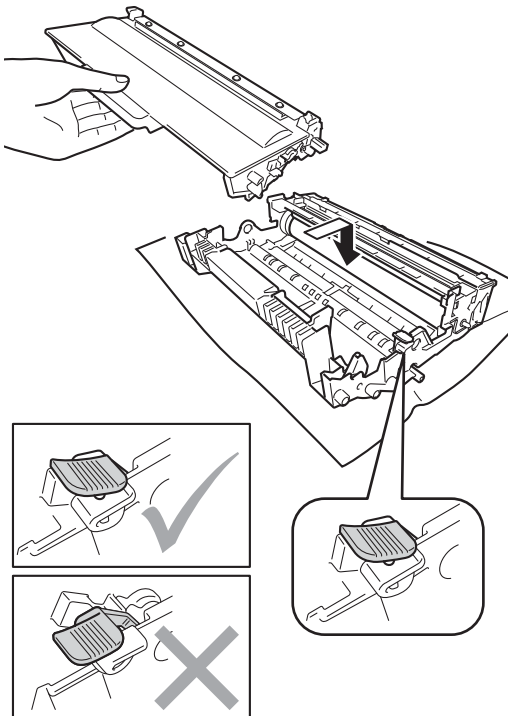

 **Note**

Make sure that you put in the toner cartridge correctly or it may separate from the drum unit.

- 8 Put the drum unit and toner cartridge assembly back into the machine.

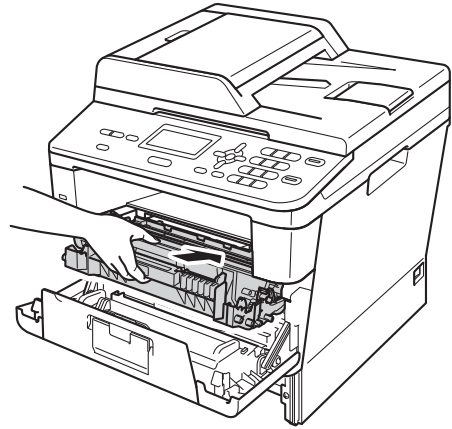

- 9 Close the front cover of the machine.  
10 Put the paper tray firmly back in the machine.

 **Note**

If you turn off the machine while **Jam Inside** is displayed, the machine will print incomplete data from your computer. Before you turn on the machine, delete the print job on your computer.

## Paper is jammed in the duplex tray

If the LCD shows **Jam Duplex**, follow these steps:

- 1 Leave the machine turned on for 10 minutes for the internal fan to cool the extremely hot parts inside the machine.
- 2 Pull the paper tray completely out of the machine.

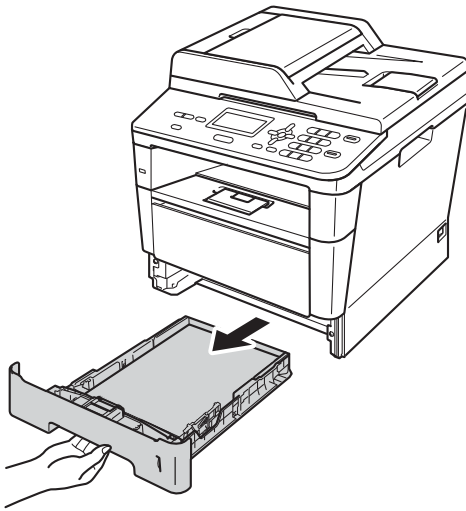

- 3 Open the back cover.

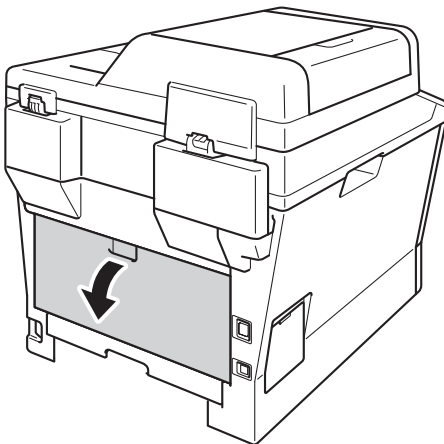

## ! WARNING

### ! HOT SURFACE

After you have just used the machine, some internal parts of the machine will be extremely hot. Wait for the machine to cool down before you touch the internal parts of the machine.

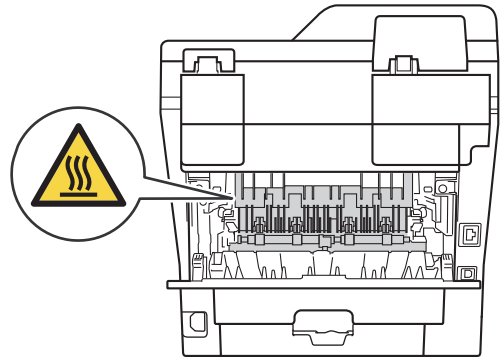

- 4 Using both hands, gently pull the jammed paper out of the back of the machine.

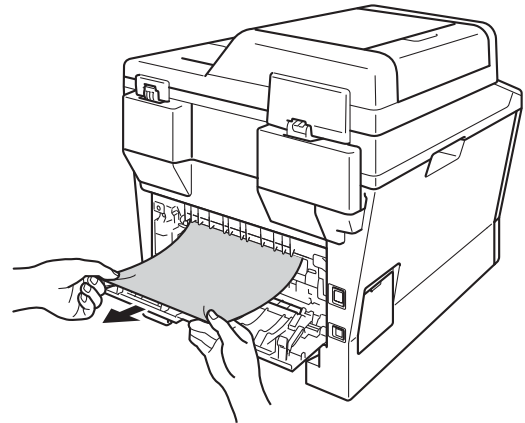

- 5 Close the back cover.

- 6 Pull the duplex tray completely out of the machine.

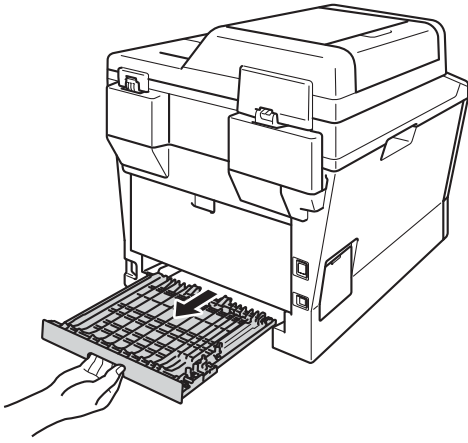

- 7 Pull the jammed paper out of the machine or out of the duplex tray.

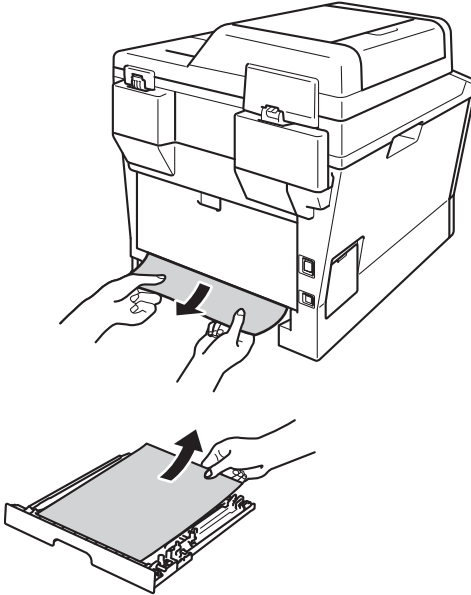

- 8 Make sure that the jammed paper does not remain under the machine from static electricity.

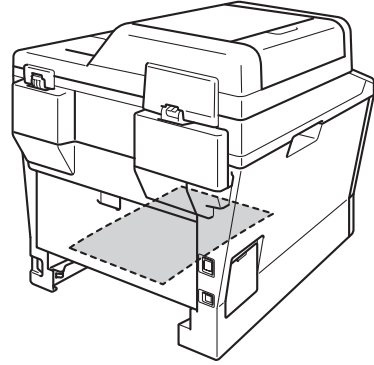

- 9 Put the duplex tray back in the machine.

- 10 Put the paper tray firmly back in the machine.





# If you are having difficulty with your machine

## ! Important

- For technical help, you must call the country where you bought the machine. Calls must be made from within that country.
- If you think there is a problem with your machine, check the chart below and follow the troubleshooting tips. You can correct most problems by yourself.
- If you need additional help, the Brother Solutions Center offers the latest FAQs and troubleshooting tips.

Visit us at <http://solutions.brother.com/>.

## Printing difficulties

| Difficulties   | Suggestions  |
|--|--|
| No printout.   | Check that the correct printer driver has been installed and selected.   |
|  | Check to see if the LCD is showing an error message.<br>See <i>Error and maintenance messages</i> >> page 62.  |
|  | Check the machine is online:<br>(Windows® 7 and Windows Server® 2008 R2)<br>Click the  ( <b>Start</b> ) button and then <b>Devices and Printers</b> . Right-click <b>Brother DCP-XXXX Printer</b> and click <b>See What's Printing</b> . Click <b>Printer</b> and make sure <b>Use Printer Offline</b> is unchecked.<br>(Windows Vista® and Windows Server® 2008)<br>Click the  ( <b>Start</b> ) button, <b>Control Panel</b> , <b>Hardware and Sound</b> , and then <b>Printers</b> . Right-click <b>Brother DCP-XXXX Printer</b> . Make sure that <b>Use Printer Offline</b> is unchecked. |
|  | (Windows® XP and Windows Server® 2003)<br>Click the <b>Start</b> button and choose <b>Printers and Faxes</b> . Right-click <b>Brother DCP-XXXX Printer</b> . Make sure that <b>Use Printer Offline</b> is unchecked.   |
|  | Contact your administrator to check your Secure Function Lock settings.  |
|  | Check if the machine is in Power Down mode.<br>Press any key on the control panel, and then re-send print data.<br>>> <i>Advanced User's Guide: Power Down mode</i>  |
| The machine is not printing or has stopped printing.   | Press <b>Stop/Exit</b> .<br>The machine will cancel the print job and clear it from the memory. The printout may be incomplete.  |
| The headers or footers appear when the document displays on the screen but they do not show up when it is printed. | There is an unprintable area on the top and bottom of the page. Adjust the top and bottom margins in your document to allow for this.<br>See <i>Unscannable and unprintable areas</i> >> page 16.  |
| The machine prints unexpectedly or it prints garbage.  | Press <b>Stop/Exit</b> to cancel print jobs.   |
|  | Check the settings in your application to make sure that it is set up to work with your machine.   |



## Printing difficulties (continued)

| Difficulties   | Suggestions   |
|--|---|
| The machine prints the first couple of pages correctly, then some pages have text missing.                               | Check the settings in your application to make sure that it is set up to work with your machine.  |
|  | Your computer is not recognising the machine's input buffer's full signal. Make sure that you have connected the interface cable correctly.<br><br>➤➤ Quick Setup Guide                       |
| The machine does not print on both sides of the paper even though the printer driver is set to Duplex.                   | Check the paper size setting in the printer driver. You need to choose A4 (60 to 105 g/m) <sup>2</sup> .  |
| The machine does not change to Direct Print mode when a USB flash memory drive is connected to the USB direct interface. | When the machine is in Deep Sleep mode, the machine does not wake up even if you connect a USB flash memory drive to the USB direct interface. Press <b>Stop/Exit</b> to wake up the machine. |
| Cannot perform 'Page Layout' printing.   | Check that the paper size setting in the application and in the printer driver are the same.  |
| Print speed is too slow.   | Try changing the printer driver setting. The highest resolution needs longer data processing, sending and printing time.  |
|  | Check that the back cover is firmly closed and the duplex tray is firmly installed.   |
|  | Add optional memory.<br><br>➤➤ Advanced User's Guide: <i>Installing extra memory</i>  |
| The machine does not print from Adobe® Illustrator®.   | Try to reduce the print resolution.<br><br>➤➤ Software User's Guide: <i>Printing</i> (for Windows®)<br><br>➤➤ Software User's Guide: <i>Printing and Faxing</i> (for Macintosh)               |
| Poor print quality   | See <i>Improving the print quality</i> ➤➤ page 87.  |

## Paper handling difficulties

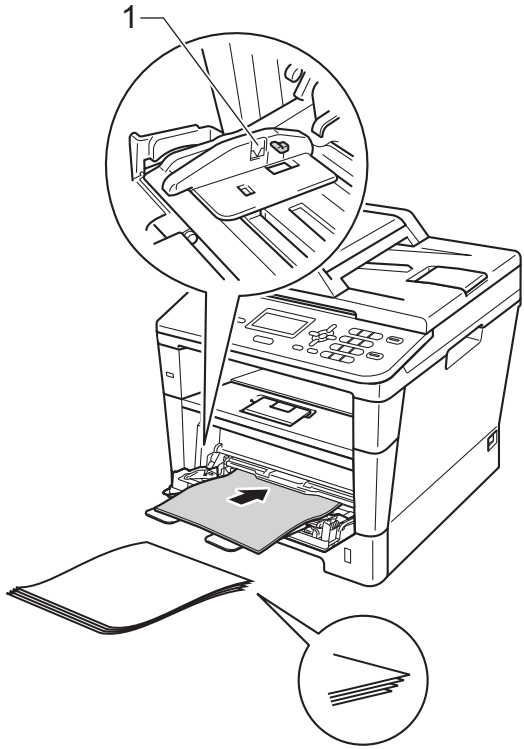
| Difficulties   | Suggestions  |
|--|--|
| <p>The machine does not feed paper.</p>  | <p>If the LCD shows the Paper Jam message and you still have a problem, see <i>Error and maintenance messages</i> &gt;&gt; page 62.</p> <p>If there is no paper, load a new stack of paper into the paper tray.</p> <p>If there is paper in the paper tray, make sure it is straight. If the paper is curled, you should straighten it. Sometimes it is helpful to remove the paper, turn the stack over and put it back into the paper tray.</p> <p>Reduce the amount of paper in the paper tray, and then try again.</p> <p>Make sure that manual feed mode is not selected in the printer driver.</p> <p>Clean the paper pick-up roller.</p> <p>See <i>Cleaning the paper pick-up rollers</i> &gt;&gt; page 59.</p> |
| <p>The machine does not feed paper from the MP tray.</p>                                   | <p>Make sure that <b>MP Tray</b> is selected in the printer driver.</p> <p>Fan the paper well and put it back in the tray firmly.</p>  |
| <p>The machine does not feed paper from the MP Tray when using a large stack of paper.</p> | <p>Fan the paper well and make sure the paper is under the maximum paper mark (1). Stagger the pages and put them in the tray until you feel the top page touch the feed rollers as shown in the illustration.</p>    |
| <p>How do I print on envelopes?</p>  | <p>You can load envelopes in the MP tray. Your application must be set up to print the envelope size you are using. This is usually done in the Page Setup or Document Setup menu of your application. (See your application's manual for more information.)</p>   |

## Copying difficulties

| Difficulties                           | Suggestions   |
|--|---|
| Cannot make a copy.                    | See <i>How to copy</i> >> page 26.<br>Contact your administrator to check your Secure Function Lock Settings.   |
| Vertical black line appears in copies. | Black vertical lines on copies are typically caused by dirt or correction fluid on the scanner glass, or the corona wire is dirty. Clean the glass strip and scanner glass and the white bar and also white plastic above them.<br><br>See <i>Cleaning the scanner glass</i> >> page 52 and <i>Cleaning the corona wire</i> >> page 53. |
| Copies are blank.                      | Make sure you are loading the document correctly.<br><br>See <i>Using the automatic document feeder (ADF)</i> >> page 24 or <i>Using the scanner glass</i> >> page 25.  |

## Scanning difficulties

| Difficulties  | Suggestions  |
|---|--|
| TWAIN or WIA errors appear when starting to scan. (Windows®)  | Make sure the Brother TWAIN or WIA driver is selected as the primary source in your scanning application. For example, in Nuance™ PaperPort™ 12SE, click <b>Scan Settings, Select</b> to choose the Brother TWAIN/WIA driver.  |
| TWAIN or ICA errors appear when starting to scan. (Macintosh) | Make sure the Brother TWAIN driver is selected as the primary source. In PageManager, click <b>File, Select Source</b> and choose the Brother TWAIN driver.<br><br>Mac OS X 10.6.x – 10.7.x users can also scan documents using the ICA Scanner Driver<br><br>>> Software User's Guide: <i>Scanning a document using the ICA driver (Mac OS X 10.6.x or greater)</i> |
| OCR does not work.  | Try increasing the scanning resolution.<br><br>(Macintosh users)<br>Presto! PageManager must be downloaded and installed before use. For further instructions, see <i>Accessing Brother Support (Macintosh)</i> >> page 5.   |
| Network scanning does not work.                               | See <i>Network difficulties</i> >> page 85.  |
| Cannot scan.  | Contact your administrator to check your Secure Function Lock Settings.  |

## Software difficulties



| Difficulties                      | Suggestions  |
|-----------------------------------|--|
| Cannot install software or print. | (Windows® only)<br>Run the <b>Repair MFL-Pro Suite</b> program on the CD-ROM. This program will repair and reinstall the software. |

## Network difficulties

| Difficulties                                       | Suggestions   |
|--|---|
| <p>Cannot print over a wired Network.</p>          | <p>Make sure your machine is powered on, is online and in the Ready mode. Print the Network Configuration Report to verify your Network settings are correct.</p> <p>➤➤ <i>Advanced User's Guide: Network Configuration Report</i></p> <p>Reconnect the LAN cable to the hub to verify that the cable and network connections are good. If possible, try connecting the machine to a different port on your hub using a different cable. You can check the current wired network status from the Network control panel menu.</p> <p>For more information on Network problems:<br/>See Network User's Guide.</p>   |
| <p>The network scanning feature does not work.</p> | <p><b>(Windows® and Macintosh)</b><br/>The network scanning feature may not work due to your firewall settings. Change or disable the firewall settings. It is necessary to set the third-party Security/Firewall Software to allow Network scanning. To add port 54925 for Network scanning, enter the information below:</p> <ul style="list-style-type: none"> <li>■ In Name: Enter any description, for example Brother NetScan.</li> <li>■ In Port number: Enter 54925.</li> <li>■ In Protocol: UDP is selected.</li> </ul> <p>Please refer to the instruction manual that came with your third-party Security/Firewall Software or contact the software manufacturer.</p> <p>For more details, you can read FAQs and troubleshooting suggestions at <a href="http://solutions.brother.com/">http://solutions.brother.com/</a>.</p> <p><b>(Macintosh)</b><br/>Re-select your machine in the <b>Device Selector</b> application located in <b>Macintosh HD/Library/Printers/Brother/Utilities/DeviceSelector</b> or from the model list in <b>ControlCenter2</b>.</p> |
| <p>The Brother software cannot be installed.</p>   | <p><b>(Windows®)</b><br/>If the Security Software warning appears on the PC screen during the installation, change the Security Software settings to permit the Brother product setup program or other programs to run.</p> <p><b>(Macintosh)</b><br/>If you are using a firewall function of anti-spyware or antivirus security software, temporarily disable it and then install the Brother software.</p>  |



## Other difficulties

| Difficulties  | Suggestions   |
|---|---|
| <p>The machine will not turn on.</p>  | <p>Adverse conditions on the power connection (such as lightning or a power surge) may have triggered the machine's internal safety mechanisms. Turn the machine off and unplug the power cord. Wait for ten minutes, then plug in the power cord and turn the machine on.</p> <p>If the problem is not solved and you are using a power breaker, disconnect it to make sure it is not the problem. Plug the machine's power cord directly into a different known working wall electrical socket. If there is still no power, try a different power cable.</p>  |
| <p>The machine cannot print EPS data that includes binary with the BR-Script3 printer driver.</p> | <p><b>(Windows®)</b><br/>You need the following settings to print EPS data:</p> <ol style="list-style-type: none"> <li>1 For Windows® 7 and Windows Server® 2008 R2:<br/>Click the  (<b>Start</b>) button and then <b>Devices and Printers</b>.<br/>For Windows Vista® and Windows Server® 2008:<br/>Click the  (<b>Start</b>) button, <b>Control Panel</b>, <b>Hardware and Sound</b>, and then <b>Printers</b>.<br/>For Windows® XP and Windows Server® 2003:<br/>Click the <b>Start</b> button, and select <b>Printers and Faxes</b>.</li> <li>2 Right-click the <b>Brother DCP-XXXX BR-Script3</b> icon and select <b>Properties</b><sup>1</sup>.</li> <li>3 From the <b>Device Settings</b> tab, choose <b>TBCP</b> (Tagged binary communication protocol) in <b>Output Protocol</b>.</li> </ol> <p><b>(Macintosh)</b><br/>If your machine is connected to a computer with a USB interface, you cannot print EPS data that includes binary. You can print EPS data at the machine via a network. To install the BR-Script3 printer driver over the network, visit the Brother Solutions Center at <a href="http://solutions.brother.com/">http://solutions.brother.com/</a>.</p> |

<sup>1</sup> For Windows® 7 and Windows Server® 2008 R2:  
**Printer properties**, and **Brother DCP-XXXX BR-Script3** if necessary

# Improving the print quality

If you have a print quality problem, print a test page first (**Menu, 3, 2, 3**). If the printout looks good, the problem is probably not the machine. Check the interface cable connections and try printing a different document. If the printout or test page printed from the machine has a quality problem, check the following steps first. And then, if you still have a print quality problem, check the chart below and follow the recommendations.





**Note**

Brother does not recommend the use of cartridges other than Brother Original cartridges or the refilling of used cartridges with toner from other sources.



- 1 To get the best print quality, we suggest using the recommended paper. Check that you use paper that meets our specifications. (See *Acceptable paper and other print media* >> page 19.)
- 2 Check that the drum unit and toner cartridge are installed correctly.

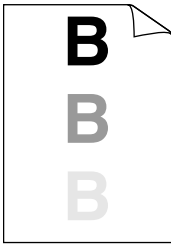

| Examples of poor print quality  | Recommendation   |
|---|--|
| <div style="text-align: center;">  <p><b>Faint</b></p> </div> | <ul style="list-style-type: none"> <li>■ Take out the drum unit and toner cartridge assembly. Hold the assembly level with both hands and gently shake it from side to side several times to spread the toner evenly inside the cartridge.</li> <li>■ If the LCD shows <i>Replace Toner</i>, put in a new toner cartridge.                     <ul style="list-style-type: none"> <li>&gt;&gt; <i>Replacing the toner cartridge</i> &gt;&gt; page 40</li> </ul> </li> <li>■ Check the machine's environment. Conditions such as humidity, high temperatures, and so on, may cause this print fault.                     <ul style="list-style-type: none"> <li>&gt;&gt; <i>Product Safety Guide: Choose a safe location for your product</i></li> </ul> </li> <li>■ If the whole page is too light, <i>Toner Save</i> may be turned on. Turn off <i>Toner Save</i> in the machine's menu settings or <b>Toner Save Mode</b> in the Printer Properties of the driver.                     <ul style="list-style-type: none"> <li>&gt;&gt; <i>Advanced User's Guide: Toner Save</i></li> <li>&gt;&gt; <i>Software User's Guide: Printing</i> (for Windows®)</li> <li>&gt;&gt; <i>Software User's Guide: Printing and Faxing</i> (for Macintosh)</li> </ul> </li> <li>■ Clean the corona wire of the drum unit.                     <ul style="list-style-type: none"> <li>&gt;&gt; <i>Cleaning the corona wire</i> &gt;&gt; page 53</li> </ul> </li> <li>■ Put in a new toner cartridge.                     <ul style="list-style-type: none"> <li>&gt;&gt; <i>Replacing the toner cartridge</i> &gt;&gt; page 40</li> </ul> </li> <li>■ Put in a new drum unit.                     <ul style="list-style-type: none"> <li>&gt;&gt; <i>Replacing the drum unit</i> &gt;&gt; page 46</li> </ul> </li> </ul> |

B

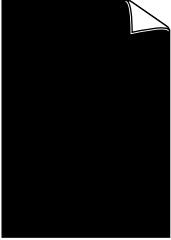

| Examples of poor print quality  | Recommendation  |
|---|---|
|  <p data-bbox="179 556 380 585">Grey background</p>  | <ul style="list-style-type: none"> <li>■ Make sure that you use paper that meets our specifications. <ul style="list-style-type: none"> <li>➤➤ <i>Acceptable paper and other print media</i> ➤➤ page 19</li> </ul> </li> <li>■ Check the machine's environment. Conditions such as high temperatures and high humidity can increase the amount of background shading. <ul style="list-style-type: none"> <li>➤➤ <i>Product Safety Guide: Choose a safe location for your product</i></li> </ul> </li> <li>■ Put in a new toner cartridge. <ul style="list-style-type: none"> <li>➤➤ <i>Replacing the toner cartridge</i> ➤➤ page 40</li> </ul> </li> <li>■ Put in a new drum unit. <ul style="list-style-type: none"> <li>➤➤ <i>Replacing the drum unit</i> ➤➤ page 46</li> </ul> </li> </ul>   |
|  <p data-bbox="226 950 332 979">Ghosting</p>         | <ul style="list-style-type: none"> <li>■ Make sure that you use paper that meets our specifications. Rough-surfaced paper or thick paper may cause this problem. <ul style="list-style-type: none"> <li>➤➤ <i>Acceptable paper and other print media</i> ➤➤ page 19</li> </ul> </li> <li>■ Make sure that you choose the appropriate media type in the printer driver or in the machine's <i>Paper Type</i> menu setting. <ul style="list-style-type: none"> <li>➤➤ <i>Paper Type</i> ➤➤ page 17</li> <li>➤➤ <i>Software User's Guide: Printing</i> (for Windows®)</li> <li>➤➤ <i>Software User's Guide: Printing and Faxing</i> (for Macintosh)</li> </ul> </li> <li>■ Choose <b>Reduce Ghosting</b> mode in the printer driver. <ul style="list-style-type: none"> <li>➤➤ <i>Software User's Guide: Printing</i> (for Windows®)</li> <li>➤➤ <i>Software User's Guide: Printing and Faxing</i> (for Macintosh)</li> </ul> </li> <li>■ Put in a new drum unit. <ul style="list-style-type: none"> <li>➤➤ <i>Replacing the drum unit</i> ➤➤ page 46</li> </ul> </li> <li>■ Put in a new toner cartridge. <ul style="list-style-type: none"> <li>➤➤ <i>Replacing the toner cartridge</i> ➤➤ page 40</li> </ul> </li> <li>■ The fuser unit may be contaminated. <ul style="list-style-type: none"> <li>Call Brother customer service for support.</li> </ul> </li> </ul> |
|  <p data-bbox="200 1657 359 1686">Toner specks</p> | <ul style="list-style-type: none"> <li>■ Make sure that you use paper that meets our specifications. Rough-surfaced paper may cause the problem. <ul style="list-style-type: none"> <li>➤➤ <i>Acceptable paper and other print media</i> ➤➤ page 19</li> </ul> </li> <li>■ Clean the corona wire on the drum unit. <ul style="list-style-type: none"> <li>➤➤ <i>Cleaning the corona wire</i> ➤➤ page 53</li> </ul> </li> <li>■ The drum unit may be damaged. Put in a new drum unit. <ul style="list-style-type: none"> <li>➤➤ <i>Replacing the drum unit</i> ➤➤ page 46</li> </ul> </li> <li>■ The fuser unit may be contaminated. <ul style="list-style-type: none"> <li>Call Brother customer service for support.</li> </ul> </li> </ul>  |

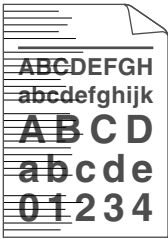

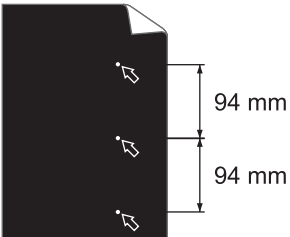
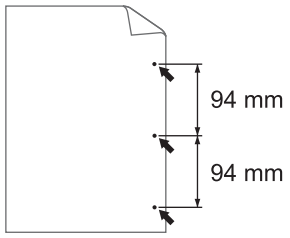

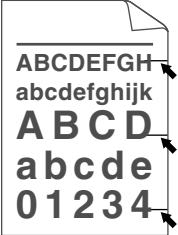
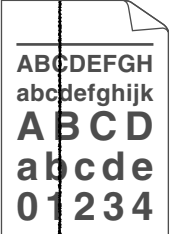
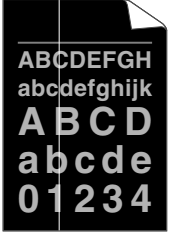
| Examples of poor print quality  | Recommendation   |
|---|--|
|  <p data-bbox="240 556 381 585"><b>Hollow print</b></p>                    | <ul style="list-style-type: none"> <li data-bbox="504 295 1167 324">■ Make sure that you use paper that meets our specifications.                             <ul style="list-style-type: none"> <li data-bbox="532 336 1130 365">➤➤ <i>Acceptable paper and other print media</i> ➤➤ page 19</li> </ul> </li> <li data-bbox="504 378 1252 465">■ Choose <b>Thick Paper</b> mode in the printer driver, choose <b>Thick</b> in the machine's <b>Paper Type</b> menu setting or use thinner paper than you are currently using.                             <ul style="list-style-type: none"> <li data-bbox="532 477 834 506">➤➤ <i>Paper Type</i> ➤➤ page 17</li> <li data-bbox="532 523 1075 552">➤➤ Software User's Guide: <i>Printing</i> (for Windows®)</li> <li data-bbox="532 568 1201 596">➤➤ Software User's Guide: <i>Printing and Faxing</i> (for Macintosh)</li> </ul> </li> <li data-bbox="504 610 1252 668">■ Check the machine's environment. Conditions such as high humidity can cause hollow print.                             <ul style="list-style-type: none"> <li data-bbox="532 681 1238 710">➤➤ Product Safety Guide: <i>Choose a safe location for your product</i></li> </ul> </li> <li data-bbox="504 724 1130 753">■ The drum unit may be damaged. Put in a new drum unit.                             <ul style="list-style-type: none"> <li data-bbox="532 767 964 795">➤➤ <i>Replacing the drum unit</i> ➤➤ page 46</li> </ul> </li> </ul> |
|  <p data-bbox="257 1072 363 1101"><b>All black</b></p>                    | <ul style="list-style-type: none"> <li data-bbox="504 811 1245 869">■ Clean the corona wire inside the drum unit by sliding the green tab. Be sure to return the green tab to the home position (▲).                             <ul style="list-style-type: none"> <li data-bbox="532 880 975 909">➤➤ <i>Cleaning the corona wire</i> ➤➤ page 53</li> </ul> </li> <li data-bbox="504 923 1130 952">■ The drum unit may be damaged. Put in a new drum unit.                             <ul style="list-style-type: none"> <li data-bbox="532 966 964 994">➤➤ <i>Replacing the drum unit</i> ➤➤ page 46</li> </ul> </li> </ul>   |
|  <p data-bbox="150 1375 470 1404"><b>White lines across the page</b></p> | <ul style="list-style-type: none"> <li data-bbox="504 1114 1252 1201">■ Make sure that you use paper that meets our specifications. A rough surfaced paper or thick print media can cause this problem. See <i>Acceptable paper and other print media</i> ➤➤ page 19.</li> <li data-bbox="504 1215 1252 1273">■ Make sure that you choose the appropriate media type in the printer driver or in the machine's <b>Paper Type</b> menu setting.                             <ul style="list-style-type: none"> <li data-bbox="532 1284 834 1313">➤➤ <i>Paper Type</i> ➤➤ page 17</li> <li data-bbox="532 1331 1075 1360">➤➤ Software User's Guide: <i>Printing</i> (for Windows®)</li> <li data-bbox="532 1375 1201 1404">➤➤ Software User's Guide: <i>Printing and Faxing</i> (for Macintosh)</li> </ul> </li> <li data-bbox="504 1418 1252 1476">■ The problem may disappear by itself. Print multiple pages to clear this problem, especially if the machine has not been used for a long time.</li> <li data-bbox="504 1489 1130 1518">■ The drum unit may be damaged. Put in a new drum unit.                             <ul style="list-style-type: none"> <li data-bbox="532 1532 957 1561">➤➤ <i>Replacing the drum unit</i> ➤➤ page 46</li> </ul> </li> </ul>   |

| Examples of poor print quality  | Recommendation   |
|---|--|
|  <p data-bbox="152 552 406 581"><b>Lines across the page</b></p>   | <ul style="list-style-type: none"> <li>■ Clean the corona wire inside the drum unit. <ul style="list-style-type: none"> <li>➤➤ <i>Cleaning the corona wire</i> ➤➤ page 53</li> </ul> </li> <li>■ The drum unit may be damaged. Put in a new drum unit. <ul style="list-style-type: none"> <li>➤➤ <i>Replacing the drum unit</i> ➤➤ page 46</li> </ul> </li> </ul>  |
|  <p data-bbox="113 852 440 909"><b>White lines, bands or ribbing across the page</b></p>   | <ul style="list-style-type: none"> <li>■ Check the machine's environment. Conditions such as high humidity and high temperatures may cause this print quality problem. <ul style="list-style-type: none"> <li>➤➤ <i>Product Safety Guide: Choose a safe location for your product</i></li> </ul> </li> <li>■ If the problem is not solved after printing a few pages, put in a new drum unit. <ul style="list-style-type: none"> <li>➤➤ <i>Replacing the drum unit</i> ➤➤ page 46</li> </ul> </li> </ul>   |
|  <p data-bbox="131 1182 426 1267"><b>White Spots on black text and graphics at 94 mm intervals</b></p>  <p data-bbox="155 1535 406 1586"><b>Black Spots at 94 mm intervals</b></p> | <ul style="list-style-type: none"> <li>■ Make 10-15 copies of a blank, white sheet of paper. If the problem is not solved after printing the blank pages, the drum unit may have foreign material, such as glue from a label, stuck on the drum. Clean the drum unit. <ul style="list-style-type: none"> <li>➤➤ <i>Cleaning the drum unit</i> ➤➤ page 55</li> </ul> </li> <li>■ The drum unit may be damaged. Put in a new drum unit. <ul style="list-style-type: none"> <li>➤➤ <i>Replacing the drum unit</i> ➤➤ page 46</li> </ul> </li> </ul> |

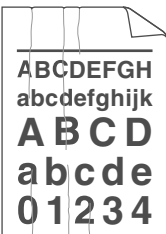
| Examples of poor print quality  | Recommendation  |
|---|---|
|  <p><b>Black toner marks across the page</b></p>   | <ul style="list-style-type: none"> <li>■ If you use label sheets for laser printers, the glue from the sheets may sometimes stick to the OPC drum surface. Clean the drum unit. <ul style="list-style-type: none"> <li>➤➤ <i>Cleaning the drum unit</i> ➤➤ page 55</li> </ul> </li> <li>■ Make sure that you use paper that meets our specifications. <ul style="list-style-type: none"> <li>➤➤ <i>Acceptable paper and other print media</i> ➤➤ page 19</li> </ul> </li> <li>■ Do not use paper that has clips or staples because they will scratch the surface of the drum.</li> <li>■ If the unpacked drum unit is in direct sunlight or room light, the unit may be damaged.</li> <li>■ The toner cartridge may be damaged. Put in a new toner cartridge. <ul style="list-style-type: none"> <li>➤➤ <i>Replacing the toner cartridge</i> ➤➤ page 40</li> </ul> </li> <li>■ The drum unit may be damaged. Put in a new drum unit. <ul style="list-style-type: none"> <li>➤➤ <i>Replacing the drum unit</i> ➤➤ page 46</li> </ul> </li> </ul> |
|  <p><b>Black lines down the page<br/>Printed pages have toner smudges down the page</b></p> | <ul style="list-style-type: none"> <li>■ Clean the corona wire inside the drum unit by sliding the green tab. <ul style="list-style-type: none"> <li>➤➤ <i>Cleaning the corona wire</i> ➤➤ page 53</li> </ul> </li> <li>■ Make sure the green tab of the corona wire is at the home position (▲).</li> <li>■ The toner cartridge may be damaged. Put in a new toner cartridge. <ul style="list-style-type: none"> <li>➤➤ <i>Replacing the toner cartridge</i> ➤➤ page 40</li> </ul> </li> <li>■ The drum unit may be damaged. Put in a new drum unit. <ul style="list-style-type: none"> <li>➤➤ <i>Replacing the drum unit</i> ➤➤ page 46</li> </ul> </li> <li>■ The fuser unit may be contaminated.<br/>Call your Brother customer service for support.</li> </ul>   |
|  <p><b>White lines down the page</b></p>   | <ul style="list-style-type: none"> <li>■ Make sure that foreign material such as a torn piece of paper, sticky notes or dust is not inside the machine and around the drum unit and toner cartridge.</li> <li>■ The toner cartridge may be damaged. Put in a new toner cartridge. <ul style="list-style-type: none"> <li>➤➤ <i>Replacing the toner cartridge</i> ➤➤ page 40</li> </ul> </li> <li>■ The drum unit may be damaged. Put in a new drum unit. <ul style="list-style-type: none"> <li>➤➤ <i>Replacing the drum unit</i> ➤➤ page 46</li> </ul> </li> </ul>   |

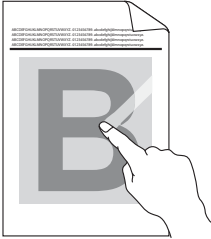
| Examples of poor print quality   | Recommendation   |
|--|--|
|  <p data-bbox="197 548 362 575">Image skewed</p>            | <ul style="list-style-type: none"> <li>■ Make sure that the paper or other print media is loaded correctly in the paper tray and that the guides are not too tight or too loose against the paper stack.</li> <li>■ Set the paper guides correctly. <ul style="list-style-type: none"> <li>➤➤ <i>Loading paper and print media</i> ➤➤ page 10</li> </ul> </li> <li>■ If you are using the MP tray, see <i>Loading paper in the multi-purpose tray (MP tray)</i> ➤➤ page 12.</li> <li>■ The paper tray may be too full. <ul style="list-style-type: none"> <li>➤➤ <i>Loading paper and print media</i> ➤➤ page 10</li> </ul> </li> <li>■ Check the paper type and quality. <ul style="list-style-type: none"> <li>➤➤ <i>Acceptable paper and other print media</i> ➤➤ page 19</li> </ul> </li> <li>■ Check for loose objects such as torn paper inside the machine.</li> <li>■ If the problem only occurs during duplex printing, check for torn paper in the duplex tray, verify that the duplex tray is inserted completely and verify that the back cover is closed completely.</li> </ul> |
|  <p data-bbox="197 1114 362 1141">Curled or wavy</p>       | <ul style="list-style-type: none"> <li>■ Check the paper type and quality. High temperatures and high humidity will cause paper to curl. <ul style="list-style-type: none"> <li>➤➤ <i>Acceptable paper and other print media</i> ➤➤ page 19</li> <li>➤➤ <i>Product Safety Guide: Choose a safe location for your product</i></li> </ul> </li> <li>■ If you do not use the machine often, the paper may have been in the paper tray too long. Turn over the stack of paper in the paper tray. Also, fan the paper stack and then rotate the paper 180° in the paper tray.</li> <li>■ Open the back cover (face-up output tray) to let the printed paper exit onto the face-up output tray.</li> <li>■ Choose <b>Reduce Paper Curl</b> mode in the printer driver when you do not use our recommended paper. <ul style="list-style-type: none"> <li>➤➤ <i>Software User's Guide: Printing</i> (for Windows®)</li> <li>➤➤ <i>Software User's Guide: Printing and Faxing</i> (for Macintosh)</li> </ul> </li> </ul>  |
|  <p data-bbox="197 1630 362 1657">Wrinkles or creases</p> | <ul style="list-style-type: none"> <li>■ Make sure that paper is loaded correctly. <ul style="list-style-type: none"> <li>➤➤ <i>Loading paper and print media</i> ➤➤ page 10</li> </ul> </li> <li>■ Check the paper type and quality. <ul style="list-style-type: none"> <li>➤➤ <i>Acceptable paper and other print media</i> ➤➤ page 19</li> </ul> </li> <li>■ Turn over the stack of paper in the tray or rotate the paper 180° in the input tray.</li> </ul>  |

| Examples of poor print quality   | Recommendation  |
|--|---|
|  <p><b>Envelope Creases</b></p> | <ul style="list-style-type: none"> <li>■ Make sure that envelopes are printed with the back cover (face-up output tray) opened.                             <ul style="list-style-type: none"> <li>➤➤ <i>Printing on thick paper, labels and envelopes from the MP tray</i></li> <li>➤➤ page 14</li> </ul> </li> <li>■ Check the envelope type and quality.                             <ul style="list-style-type: none"> <li>➤➤ <i>Acceptable paper and other print media</i> ➤➤ page 19</li> </ul> </li> <li>■ Make sure envelopes are fed only from the MP tray.                             <ul style="list-style-type: none"> <li>➤➤ <i>Loading paper in the multi-purpose tray (MP tray)</i> ➤➤ page 12</li> </ul> </li> </ul> |
|  <p><b>Poor fixing</b></p>      | <ul style="list-style-type: none"> <li>■ Choose <b>Improve Toner Fixing</b> mode in the printer driver.                             <ul style="list-style-type: none"> <li>➤➤ Software User's Guide: <i>Printing</i> (for Windows®)</li> <li>➤➤ Software User's Guide: <i>Printing and Faxing</i> (for Macintosh)</li> </ul> </li> </ul> <p>If this selection does not provide enough improvement, change the printer driver setting in <b>Media Type</b> to a thick setting.</p>   |
|  <p><b>Curled</b></p>          | <ul style="list-style-type: none"> <li>■ Choose <b>Reduce Paper Curl</b> mode in the printer driver.                             <ul style="list-style-type: none"> <li>➤➤ Software User's Guide: <i>Printing</i> (for Windows®)</li> <li>➤➤ Software User's Guide: <i>Printing and Faxing</i> (for Macintosh)</li> </ul> </li> <li>■ Open the back cover (face-up output tray) to let the printed paper exit onto the face-up output tray.</li> </ul>  |

# Machine Information

## Checking the Serial Number

---

You can see the machine's Serial Number on the LCD.

- 1 Press **Menu**, **6**, **2**.
- 2 Press **Stop/Exit**.

## Reset functions

---

The following reset functions are available:

### 1 Network

You can reset the internal print server back to its default factory settings such as the password and IP address information.

### 2 All Settings

You can reset all the machine's settings back to the factory default.

Brother strongly recommends you perform this operation when you dispose of the machine.



### Note

---

Unplug the interface cable before you choose **Network** or **All Settings**.

---

## How to reset the machine

---

- 1 Press **Menu**, **1**, **9**.
- 2 Press **▲** or **▼** to choose the reset function you want to use.  
Press **OK**.
- 3 Do one of the following;
  - To reset the settings, press **1** and go to step 4.
  - To exit without making changes, press **2** and go to step 5.
- 4 You will be asked to reboot the machine. Do one of the following;
  - To reboot the machine press **1**. The machine will begin the reset.
  - To exit without rebooting the machine, press **2**. Go to step 5.

If you do not reboot your machine, the reset will not complete and your settings will remain unchanged.

- 5 Press **Stop/Exit**.



### Note

---

You can also reset the Network settings by pressing **Menu**, **5**, **0**.

---

## On-screen programming

Your machine has been designed to be easy to use. The LCD provides on-screen programming using the menu keys.

We have created step by step on-screen instructions to help you program your machine. Simply follow the steps as they guide you through the menu selections and programming options.

### How to access the menu mode

---

- 1 Press **Menu**.
- 2 Choose an option.
  - Press **1** for General Setup menu.
  - Press **2** for Copy menu.
  - Press **3** for Printer menu.
  - Press **4** for USB Direct I/F menu.
  - Press **5** for Network menu.
  - Press **6** for Machine Info. menu.

You can also scroll through each menu level by pressing **▲** or **▼** for the direction you want.

- 3 Press **OK** when the option you want appears on the LCD.  
The LCD will then show the next menu level.
- 4 Press **▲** or **▼** to scroll to your next menu selection.
- 5 Press **OK**.  
When you have finished setting an option, the LCD will show *Accepted*.
- 6 Press **Stop/Exit** to exit Menu mode.

# Menu table

The factory settings are shown in Bold with an asterisk.

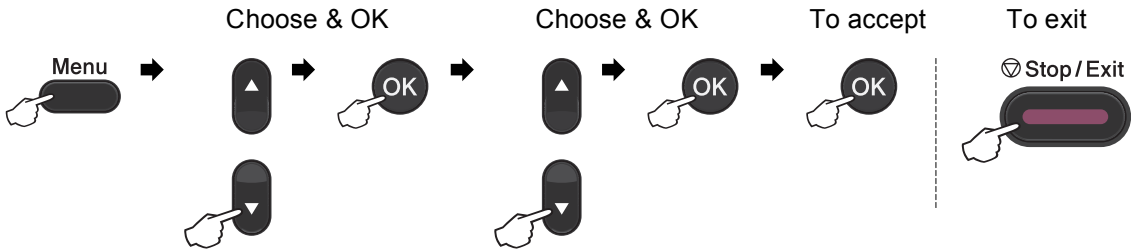









| Level 1   | Level 2 | Level 3      | Level 4  | Options  | Descriptions                              | Page |
|---|---------|--------------|--|--|---|------|
| 1.General Setup   | 1.Paper | 1.Paper Type | 1.MP Tray  | Thin<br><b>Plain*</b><br>Thick<br>Thicker<br>Recycled Paper<br>Label | Sets the type of paper in the paper tray. | 17   |
|   |         |              | 2.Tray#1   | Thin<br><b>Plain*</b><br>Thick<br>Thicker<br>Recycled Paper          | Sets the type of paper in the paper tray. | 17   |
|   |         |              | 3.Tray#2<br>(This menu appears if you have installed the optional lower tray.) | Thin<br><b>Plain*</b><br>Thick<br>Thicker<br>Recycled Paper          | Sets the type of paper in the paper tray. | 17   |
| <p>◆ <i>Advanced User's Guide</i></p> <p>‡ <i>Quick Setup Guide</i></p> <p>□ <i>Software User's Guide</i></p>                                       |         |              |  |  |   |      |
| <p> The factory settings are shown in Bold with an asterisk.</p> |         |              |  |  |   |      |





| Level 1   | Level 2                | Level 3      | Level 4  | Options  | Descriptions                                  | Page |
|---|------------------------|--------------|--|--|---|------|
| 1.General Setup<br>(Continued)  | 1.Paper<br>(Continued) | 2.Paper Size | 1.MP Tray  | <b>A4*</b><br>Letter<br>Legal<br>Executive<br>A5<br>A5 L<br>A6<br>B5<br>B6<br>Folio<br>Any | Sets the size of the paper in the paper tray. | 17   |
|   |                        |              | 2.Tray#1   | <b>A4*</b><br>Letter<br>Legal<br>Executive<br>A5<br>A5 L<br>A6<br>B5<br>B6<br>Folio        | Sets the size of the paper in the paper tray. | 17   |
|   |                        |              | 3.Tray#2<br>(This menu appears if you have installed the optional lower tray.) | <b>A4*</b><br>Letter<br>Legal<br>Executive<br>A5<br>B5<br>B6<br>Folio                      | Sets the size of the paper in the paper tray. | 17   |
|   | 2.Beeper               | —            | —  | Low<br><b>Med*</b><br>High<br>Off  | Adjusts the volume level of the beeper.       | 9    |
| <p>◆ <i>Advanced User's Guide</i></p> <p>‡ <i>Quick Setup Guide</i></p> <p>□ <i>Software User's Guide</i></p>                                       |                        |              |  |  |   |      |
| <p> The factory settings are shown in Bold with an asterisk.</p> |                        |              |  |  |   |      |

| Level 1  | Level 2      | Level 3          | Level 4   | Options  | Descriptions                                       | Page           |
|--|--------------|------------------|---|--|--|----------------|
| 1.General Setup<br>(Continued)   | 3.Ecology    | 1.Toner Save     | —   | On<br><b>Off*</b>  | Increases the page yield of the toner cartridge.   | See <b>◆</b> . |
|  |              | 2.Sleep Time     | —   | Range varies depending on models.<br><b>03Min*</b>   | Conserves power.                                   |                |
|  |              | 3.Auto Powerdown | —   | <b>On*</b><br>Off  | Enables or disables Power Down mode.               |                |
|  | 4.Quiet Mode | —                | —   | On<br><b>Off*</b>  | Decreases printing noise.                          |                |
|  | 5.Tray Use   | 1.Copy           | —   | Tray#1 Only<br>Tray#2 Only<br>MP Only<br><b>MP&gt;T1&gt;T2*</b><br>T1>T2>MP<br>(Tray#2 and T2 appear if you have installed the optional lower tray.) | Chooses the tray that will be used for COPY mode.  | 18             |
|  |              | 2.Print          | —   | Tray#1 Only<br>Tray#2 Only<br>MP Only<br><b>MP&gt;T1&gt;T2*</b><br>T1>T2>MP<br>(Tray#2 and T2 appear if you have installed the optional lower tray.) | Chooses the tray that will be used for Print mode. | 18             |
| 6.LCD Contrast   | —            | —                | -□□□■+<br>-□□□■+<br>-□□■□+*<br>-□■□□+<br>-■□□□+ | Adjusts the contrast of the LCD.   | See <b>◆</b> .                                     |                |
| <b>◆ Advanced User's Guide</b><br><b>‡ Quick Setup Guide</b><br><input type="checkbox"/> <b>Software User's Guide</b>                        |              |                  |   |  |  |                |
|  The factory settings are shown in Bold with an asterisk. |              |                  |   |  |  |                |

| Level 1                        | Level 2  | Level 3          | Level 4 | Options                   | Descriptions  | Page  |   |
|--------------------------------|--|------------------|---------|---------------------------|---|---|---|
| 1.General Setup<br>(Continued) | 7.Security   | 1.Function Lock  | —       | —                         | Can restrict selected machine operations for up to 25 individual users and all other non-authorized Public users. | See  |   |
|                                |  | 2.Setting Lock   | —       | —                         | Stops unauthorized users from changing the machine's current settings.  |   |   |
|                                | 8.Document Scan  | 1.Glass ScanSize | —       | —                         | A4*<br>Letter   | Adjusts the scan area of the scanner glass to the size of the document.                 | See    |
|                                |  | 2.File Size      | 1.Color | Small<br>Medium*<br>Large | You can set your own default settings for the data compression ratio.   |   |   |
|                                |  |                  | 2.Gray  | Small<br>Medium*<br>Large |   |   |   |
|                                | 9.Reset  | 1.Network        | —       | —                         | 1.Reset<br>2.Exit   | Restores all network settings to factory default.                                       | 94  |
|                                |  | 2.All Settings   | —       | —                         | 1.Reset<br>2.Exit   | Restores all the machine settings to factory default.                                   |   |
|                                | 0.Local Language   | —                | —       | —                         | (Choose your language.)   | Allows you to change the LCD language for your country.                                 | See  |
|                                |  <i>Advanced User's Guide</i><br> <i>Quick Setup Guide</i><br> <i>Software User's Guide</i> |                  |         |                           |   |   |   |
|                                |  The factory settings are shown in Bold with an asterisk.   |                  |         |                           |   |   |   |

| Level 1  | Level 2       | Level 3 | Options   | Descriptions  | Page  |
|--|---------------|---------|---|---|---|
| 2. Copy  | 1. Quality    | —       | Auto*<br>Text<br>Photo<br>Graph                 | You can choose the Copy resolution for your type of document. | See  . |
|  | 2. Brightness | —       | -□□□■+<br>-□□□■+<br>-□□■□+*<br>-□■□□+<br>-■□□□+ | Adjust the brightness for copies.                             |   |
|  | 3. Contrast   | —       | -□□□■+<br>-□□□■+<br>-□□■□+*<br>-□■□□+<br>-■□□□+ | Adjusts the contrast for copies.                              |   |
|  <i>Advanced User's Guide</i>                             |               |         |   |   |   |
|  The factory settings are shown in Bold with an asterisk. |               |         |   |   |   |

| Level 1  | Level 2          | Level 3             | Options   | Descriptions  | Page                           |
|--|------------------|---------------------|---|---|--------------------------------|
| 3. Printer   | 1. Emulation     | —                   | <b>Auto (EPSON) *</b><br>Auto (IBM)<br>HP LaserJet<br>BR-Script 3<br>Epson FX-850<br>IBM Proprinter | Chooses the emulation mode.   | See <input type="checkbox"/> . |
|  | 2. Print Options | 1. Internal Font    | 1. HP LaserJet<br>2. BR-Script 3  | Prints a list of the machine's internal fonts.  |                                |
|  |                  | 2. Configuration    | —   | Prints a list of the machine's printer settings.  |                                |
|  |                  | 3. Test Print       | —   | Prints a test page.   |                                |
|  | 3. Duplex        | —                   | On (Long Edge)<br>On (Short Edge)<br><b>Off*</b>  | Enables or disables duplex printing. You can also choose long edge or short edge duplex printing.   |                                |
|  | 4. Auto Continue | —                   | <b>On*</b><br>Off   | If this setting is enabled the machine will automatically clear a paper size error, and will use any compatible paper from the other paper trays. |                                |
| 5. Reset Printer   | —                | 1. Reset<br>2. Exit | Restores the printer settings to the original factory default settings.                             |   |                                |
| <input type="checkbox"/> Software User's Guide   |                  |                     |   |   |                                |
|  The factory settings are shown in Bold with an asterisk. |                  |                     |   |   |                                |

| Level 1  | Level 2        | Level 3         | Options  | Descriptions   | Page |
|--|----------------|-----------------|--|--|------|
| 4.USB Direct I/F   | 1.Direct Print | 1.Paper Size    | <b>A4*</b><br>Letter<br>Legal<br>Executive<br>A5<br>A5 L<br>A6<br>B5<br>B6<br>Folio  | Sets the paper size when printing directly from the USB flash memory drive.                    | 27   |
|  |                | 2.Media Type    | Thin<br><b>Plain*</b><br>Thick<br>Thicker<br>Recycled Paper<br>Label   | Sets the media type when printing directly from the USB flash memory drive.                    | 27   |
|  |                | 3.Multiple Page | <b>1in1*</b><br>2in1<br>4in1<br>9in1<br>16in1<br>25in1<br>1 in 2x2 pages<br>1 in 3x3 pages<br>1 in 4x4 pages<br>1 in 5x5 pages | Sets the page style when printing multiple pages directly from the USB Flash memory drive.     | 28   |
|  |                | 4.Orientation   | <b>Portrait*</b><br>Landscape  | Sets the page orientation when printing directly from the USB Flash memory drive.              | 28   |
|  |                | 5.Collate       | <b>On*</b><br>Off  | Enables or disables the page collation when printing directly from the USB Flash memory drive. | 28   |
| <input type="checkbox"/> Software User's Guide   |                |                 |  |  |      |
|  The factory settings are shown in Bold with an asterisk. |                |                 |  |  |      |

| Level 1  | Level 2                       | Level 3         | Options  | Descriptions  | Page                           |
|--|-------------------------------|-----------------|--|---|--------------------------------|
| 4.USB Direct I/F<br>(Continued)  | 1.Direct Print<br>(Continued) | 6.Print Quality | <b>Normal*</b><br>Fine   | Sets the print quality option when printing directly from the USB Flash memory drive.                 | 28                             |
|  |                               | 7.PDF Option    | <b>Document*</b><br>Document&Markup<br>Document&Stamps   | Sets the PDF option whether to print comments (Markup) or stamps in the PDF file along with the text. | 28                             |
|  |                               | 8.Index Print   | <b>Simple*</b><br>Details  | Sets the index print option, simple format or details.  | 28                             |
|  | 2.Scan to USB                 | 1.Resolution    | <b>Color 100 dpi*</b><br>Color 200 dpi<br>Color 300 dpi<br>Color 600 dpi<br>Color Auto<br>Gray 100 dpi<br>Gray 200 dpi<br>Gray 300 dpi<br>Gray Auto<br>B&W 300 dpi<br>B&W 200 dpi<br>B&W 200x100 dpi | Sets the resolution to send the scanned data to USB Flash memory drive.                               | See <input type="checkbox"/> . |
|  |                               | 2.File Name     | —  | Enter the file name of the scanned data.  |                                |
| <input type="checkbox"/> Software User's Guide   |                               |                 |  |   |                                |
|  The factory settings are shown in Bold with an asterisk. |                               |                 |  |   |                                |

| Level 1  | Level 2  | Level 3  | Level 4   | Options   | Descriptions  | Page   |
|--|----------|--|---|---|---|--------|
| 5.Network  | 1.TCP/IP | 1.Boot Method  | —   | <b>Auto*</b><br>Static<br>RARP<br>BOOTP<br>DHCP     | Chooses the BOOT method that best suits your needs.   | See +. |
|  |          | (IP Boot Tries)  | —   | <b>00003*</b><br>[00000-32767]                      | Specifies the number of attempts the machine will try to obtain an IP address when the Boot Method is set to any setting except Static. |        |
|  |          | 2.IP Address   | —   | [000-255].<br>[000-255].<br>[000-255].<br>[000-255] | Enter the IP address.   |        |
|  |          | 3.Subnet Mask  | —   | [000-255].<br>[000-255].<br>[000-255].<br>[000-255] | Enter the Subnet mask.  |        |
|  |          | 4.Gateway  | —   | [000-255].<br>[000-255].<br>[000-255].<br>[000-255] | Enter the Gateway address.  |        |
|  |          | 5.Node Name  | —   | BRNXXXXXXXXXXXX                                     | Enter the Node name. (Up to 32 characters)  |        |
|  |          | 6.WINS Config  | —   | <b>Auto*</b><br>Static                              | Chooses the WINS configuration mode.  |        |
| 7.WINS Server  | —        | Primary<br>[000-255].<br>[000-255].<br>[000-255].<br>[000-255]<br>Secondary<br>[000-255].<br>[000-255].<br>[000-255].<br>[000-255] | Specifies the IP address of the primary or secondary WINS server. |   |   |        |
| + Network User's Guide   |          |  |   |   |   |        |
|  The factory settings are shown in Bold with an asterisk. |          |  |   |   |   |        |



| Level 1  | Level 2                  | Level 3       | Level 4 | Options  | Descriptions   | Page   |
|--|--------------------------|---------------|---------|--|--|--------|
| 5. Network<br>(Continued)  | 1. TCP/IP<br>(Continued) | 8. DNS Server | —       | Primary<br>[000-255].<br>[000-255].<br>[000-255].<br>[000-255]<br>Secondary<br>[000-255].<br>[000-255].<br>[000-255].<br>[000-255] | Specifies the IP address of the primary or secondary DNS server.   | See +. |
|  |                          | 9. APIPA      | —       | On*<br>Off   | Automatically allocates the IP address from the link-local address range.  |        |
|  |                          | 0. IPv6       | —       | On<br>Off*   | Enable or Disable the IPv6 protocol. If you want to use the IPv6 protocol, visit <a href="http://solutions.brother.com/">http://solutions.brother.com/</a> for more information. |        |
|  | 2. Ethernet              | —             | —       | Auto*<br>100B-FD<br>100B-HD<br>10B-FD<br>10B-HD  | Chooses the Ethernet link mode.  |        |
|  | 3. Status                | —             | —       | Active 100B-FD<br>Active 100B-HD<br>Active 10B-FD<br>Active 10B-HD<br>Inactive   | Shows the Ethernet link status.  |        |
| 4. MAC Address   | —                        | —             | —       | Shows the MAC address of the machine.  |  |        |
| + Network User's Guide   |                          |               |         |  |  |        |
|  The factory settings are shown in Bold with an asterisk. |                          |               |         |  |  |        |

| Level 1                  | Level 2                        | Level 3 | Level 4 | Options  | Descriptions  | Page   |
|--------------------------|--------------------------------|---------|---------|--|---|--------|
| 5.Network<br>(Continued) | 5.Scan To FTP                  | —       | —       | <b>Color 100 dpi*</b><br>Color 200 dpi<br>Color 300 dpi<br>Color 600 dpi<br>Color Auto<br>Gray 100 dpi<br>Gray 200 dpi<br>Gray 300 dpi<br>Gray Auto<br>B&W 300 dpi<br>B&W 200 dpi<br>B&W 200x100 dpi | Chooses the file format to send the scanned data via FTP.   | See +. |
|                          | 6.ScanTo Network<br>(Windows®) | —       | —       | <b>Color 100 dpi*</b><br>Color 200 dpi<br>Color 300 dpi<br>Color 600 dpi<br>Color Auto<br>Gray 100 dpi<br>Gray 200 dpi<br>Gray 300 dpi<br>Gray Auto<br>B&W 300 dpi<br>B&W 200 dpi<br>B&W 200x100 dpi | You can scan a black and white or colour document directly to a CIFS server on your local network or on the Internet. |        |
|                          | 0.Network Reset                | —       | —       | 1.Reset<br>2.Exit  | Restore all network settings to the factory defaults.   |        |

+ Network User's Guide



The factory settings are shown in Bold with an asterisk.

| Level 1   | Level 2          | Level 3         | Options                        | Descriptions  | Page   |
|---|------------------|-----------------|--------------------------------|---|--------|
| 6.Machine Info.   | 1.Date&Time      | 1.Date&Time     | —                              | Puts the date and time on the LCD.  | See ‡. |
|   |                  | 2.Auto Daylight | On*<br>Off                     | Changes to Daylight Saving Time automatically.  | See ◆. |
|   |                  | 3.Time Zone     | UTCXXX:XX                      | Sets the time zone for your country.  | See †. |
|   | 2.Serial No.     | —               | —                              | You can check the serial number of your machine.  | 94     |
|   | 3.Page Counter   | —               | Total<br>List<br>Copy<br>Print | You can check the number of total pages the machine has printed during its life.  | See ◆. |
|   | 4.User Settings  | —               | —                              | Lists your settings.  |        |
|   | 5.Network Config | —               | —                              | Lists your Network settings.  |        |
|   | 6.Drum Dot Print | —               | —                              | Prints the drum dot check sheet.  |        |
|   | 7.Parts Life     | 1.Drum          | —                              | You can check the percentage of a machine part's life that remains available.<br><br>(PF Kit 2 appears only if you have installed the optional paper tray.) |        |
|   |                  | 2.Fuser         | —                              |   |        |
|   |                  | 3.Laser         | —                              |   |        |
|   |                  | 4.PF Kit MP     | —                              |   |        |
|   |                  | 5.PF Kit 1      | —                              |   |        |
| 6.PF Kit 2  |                  | —               |                                |   |        |
| ◆ <i>Advanced User's Guide</i>  |                  |                 |                                |   |        |
| ‡ <i>Quick Setup Guide</i>  |                  |                 |                                |   |        |
| † <i>Network User's Guide</i>   |                  |                 |                                |   |        |
|  The factory settings are shown in <b>Bold</b> with an asterisk. |                  |                 |                                |   |        |

# Entering text

When setting certain menu selections, you will need to type text characters. The numeric keys have letters printed on them. The keys: **0**, **#** and **\*** do *not* have printed letters because they are used for special characters.

Press the appropriate numeric key the number of times shown in this reference table to access the character you want.

| Press Key | one time | two times | three times | four times | five times | six times | seven times | eight times | nine times |
|-----------|----------|-----------|-------------|------------|------------|-----------|-------------|-------------|------------|
| 1         | @        | .         | /           | 1          | @          | .         | /           | 1           | @          |
| 2         | a        | b         | c           | A          | B          | C         | 2           | a           | b          |
| 3         | d        | e         | f           | D          | E          | F         | 3           | d           | e          |
| 4         | g        | h         | i           | G          | H          | I         | 4           | g           | h          |
| 5         | j        | k         | l           | J          | K          | L         | 5           | j           | k          |
| 6         | m        | n         | o           | M          | N          | O         | 6           | m           | n          |
| 7         | p        | q         | r           | s          | P          | Q         | R           | S           | 7          |
| 8         | t        | u         | v           | T          | U          | V         | 8           | t           | u          |
| 9         | w        | x         | y           | z          | W          | X         | Y           | Z           | 9          |

For menu selections that do not allow lower case letter selection, please use this reference table.

| Press Key | one time | two times | three times | four times | five times |
|-----------|----------|-----------|-------------|------------|------------|
| 2         | A        | B         | C           | 2          | A          |
| 3         | D        | E         | F           | 3          | D          |
| 4         | G        | H         | I           | 4          | G          |
| 5         | J        | K         | L           | 5          | J          |
| 6         | M        | N         | O           | 6          | M          |
| 7         | P        | Q         | R           | S          | 7          |
| 8         | T        | U         | V           | 8          | T          |
| 9         | W        | X         | Y           | Z          | 9          |

## Inserting spaces

To enter a space, press ► twice between characters.

## Making corrections

If you entered a character incorrectly and want to change it, press ◀ or ▶ to move the cursor to the incorrect character, and then press **Clear**.

## Repeating letters

To enter a letter on the same key as the previous letter, press ► to move the cursor right before pressing the key again.

### Special characters and symbols

Press \*, # or 0, then press ◀ or ▶ to move the cursor to the symbol or character you want. Press **OK** to choose it. The symbols and characters below will appear depending on your menu selection.

|         |     |  |
|---------|-----|--|
| Press * | for | (space) ! " # \$ % & ' ( ) * + , - . / |
| Press # | for | : ; < = > ? @ [ ] ^ _ \ ~ '   { }      |
| Press 0 | for | Ä Ê Ö Ü À Ç È É 0                      |

# D

# Specifications

## General

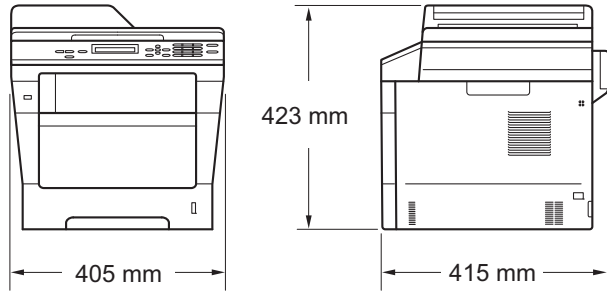
|  |                         |   |
|--|-------------------------|---|
| <b>Model</b>                                       |                         | <b>DCP-8110DN</b>   |
| <b>Printer Type</b>                                |                         | Laser   |
| <b>Print Method</b>                                |                         | Electrophotographic Laser Printer   |
| <b>Memory Capacity</b>                             | Standard                | 64 MB   |
|  | Optional                | 1 slot: DDR2 SO-DIMM (144-pin) up to 256 MB   |
| <b>LCD (liquid crystal display)</b>                |                         | 22 characters × 5 lines   |
| <b>Power Source</b>                                |                         | 220 - 240 V AC 50/60 Hz   |
| <b>Power Consumption</b> <sup>1</sup><br>(Average) | Peak                    | Approx. 1200 W at 25 °C   |
|  | Copying                 | Approx. 651 W at 25 °C  |
|  | Copying<br>(Quiet Mode) | Approx. 336 W at 25 °C  |
|  | Ready                   | Approx. 8.1 W at 25 °C  |
|  | Deep Sleep              | Approx. 1.2 W   |
|  | Power Down              | Approx. 0.26 W  |
| <b>Dimensions</b>                                  |                         |  <p>Technical drawing of the DCP-8110DN printer showing front and side views with dimensions: 405 mm width, 415 mm depth, and 423 mm height.</p> |
| <b>Weights (with consumables)</b>                  |                         | 15.6 kg   |

<sup>1</sup> USB connections to PC

| Model                           |                | DCP-8110DN   |                                  |
|---------------------------------|----------------|--|----------------------------------|
| Noise Level                     | Sound Pressure | Printing   | LPAm = 59 dB (A)                 |
|                                 |                | Ready  | LPAm = 37 dB (A)                 |
|                                 | Sound Power    | Copying <sup>1 2</sup>   | LWAd = 6.64 B (A)                |
|                                 |                | Ready <sup>1 2</sup>   | LWAd = 4.62 B (A)                |
|                                 |                | Printing (Quiet Mode)  | LWAd = 6.4 B (A)                 |
| Temperature                     |                | Operating  | 10 to 32.5 °C                    |
|                                 |                | Storage  | 0 to 40 °C                       |
| Humidity                        |                | Operating  | 20 to 80% (without condensation) |
|                                 |                | Storage  | 10 to 90% (without condensation) |
| ADF (automatic document feeder) |                | Up to 35 pages<br>For best results we recommend:<br>Temperature: 20 to 30 °C<br>Humidity: 50% to 70%<br>Paper: 80 g/m <sup>2</sup> |                                  |

<sup>1</sup> Measured in accordance with the method described in RAL-UZ122.

<sup>2</sup> Office equipment with LWAd>6.30 B (A) is not suitable for use in rooms where people do primarily intellectual work. Such equipment should be placed in separate rooms because of the noise emission.

## Document Size

| Model                           |                      | DCP-8110DN        |
|---------------------------------|----------------------|-------------------|
| Document Size<br>(Single-sided) | ADF Width            | 147.3 to 215.9 mm |
|                                 | ADF Length           | 147.3 to 355.6 mm |
|                                 | Scanner Glass Width  | Max. 215.9 mm     |
|                                 | Scanner Glass Length | Max. 300.0 mm     |



## Print media

| Model                            |                              | DCP-8110DN  |   |
|----------------------------------|------------------------------|---|---|
| <b>Paper Input</b>               | Paper Tray (Standard)        | Paper Type  | Plain Paper, Thin Paper, Recycled Paper   |
|                                  |                              | Paper Size  | A4, Letter, B5 (ISO/JIS), A5, A5 (Long Edge), B6 (ISO), A6, Executive, Legal, Folio                                   |
|                                  |                              | Paper Weight  | 60 to 105 g/m <sup>2</sup>  |
|                                  |                              | Maximum Paper Capacity  | Up to 250 sheets of 80 g/m <sup>2</sup> Plain paper   |
|                                  | Multi-purpose tray (MP tray) | Paper Type  | Plain Paper, Thin Paper, Thick Paper, Thicker Paper, Recycled Paper, Bond Paper, Label, Envelope, Env.Thin, Env.Thick |
|                                  |                              | Paper Size  | Width: 76.2 to 215.9 mm<br>Length: 127.0 to 355.6 mm  |
|                                  |                              | Paper Weight  | 60 to 163 g/m <sup>2</sup>  |
|                                  |                              | Maximum Paper Capacity  | Up to 50 sheets of 80 g/m <sup>2</sup> Plain paper  |
|                                  | Paper Tray 2 (Optional)      | Paper Type  | Plain Paper, Thin Paper, Recycled Paper   |
|                                  |                              | Paper Size  | A4, Letter, B5 (ISO/JIS), A5, B6 (ISO), Executive, Legal, Folio   |
|                                  |                              | Paper Weight  | 60 to 105 g/m <sup>2</sup>  |
|                                  |                              | Maximum Paper Capacity  | Up to 500 sheets of 80 g/m <sup>2</sup> Plain paper   |
| <b>Paper Output</b> <sup>1</sup> | Face-Down Output Tray        | Up to 150 sheets of 80 g/m <sup>2</sup> Plain Paper (face-down delivery to the face-down output paper tray) |   |
|                                  | Face-Up Output Tray          | One sheet (face-up delivery to the face-up output tray)   |   |
| <b>Duplex</b>                    | Automatic Duplex Printing    | Paper Type  | Plain Paper, Thin Paper, Recycled Paper   |
|                                  |                              | Paper Size  | A4  |
|                                  |                              | Paper Weight  | 60 to 105 g/m <sup>2</sup>  |

<sup>1</sup> For labels, we recommend removing printed pages from the output paper tray immediately after they exit the machine to avoid the possibility of smudging.

# Copy

|   |   |
|---|---|
| <b>Model</b>                            | <b>DCP-8110DN</b>                       |
| <b>Copy Width</b>                       | Max. 210 mm                             |
| <b>Multiple Copies</b>                  | Stacks or Sorts up to 99 pages          |
| <b>Reduce/Enlarge</b>                   | 25% to 400% (in increments of 1%)       |
| <b>Resolution</b>                       | Up to 1200 × 600 dpi                    |
| <b>First Copy Out Time</b> <sup>1</sup> | Less than 10.5 seconds at 23 °C / 230 V |

<sup>1</sup> From Ready mode and standard tray

# Scanner

| Model           | DCP-8110DN   |
|-----------------|--|
| Colour / Black  | Yes / Yes  |
| TWAIN Compliant | Yes (Windows® XP / Windows Vista® / Windows® 7 / Mac OS X 10.5.8, 10.6.x, 10.7.x <sup>1</sup> )  |
| WIA Compliant   | Yes (Windows® XP / Windows Vista® / Windows® 7)  |
| ICA Compliant   | Yes (Mac OS X 10.6.x, 10.7.x)  |
| Colour Depth    | 48 bit internal / 24 bit external colour   |
| Resolution      | Up to 19200 × 19200 dpi (interpolated) <sup>2</sup><br>Up to 1200 × 1200 dpi (optical) <sup>2</sup> (from Scanner Glass)<br>Up to 1200 × 600 dpi (optical) <sup>2</sup> (from ADF) |
| Scanning Width  | Max. 210 mm  |
| Greyscale       | 256 levels   |

<sup>1</sup> For the latest driver updates for the version of Mac OS X you are using, visit us at <http://solutions.brother.com/>.

<sup>2</sup> Maximum 1200 × 1200 dpi scanning with the WIA driver in Windows® XP, Windows Vista® and Windows® 7 (resolution up to 19200 × 19200 dpi can be selected by using the scanner utility)

# Printer

| Model                            | DCP-8110DN  |
|----------------------------------|---|
| Automatic 2-sided (Duplex) Print | Yes   |
| Emulations                       | PCL6, BR-Script3 (PostScript® 3™), IBM Proprinter XL, Epson FX-850      |
| Resolution                       | 1200 dpi × 1200 dpi, HQ1200 (2400 × 600 dpi) quality, 600 dpi × 600 dpi |
| Print Speed (Duplex)             | Up to 18 sides/minute (Up to 9 sheets/minute) (A4 size) <sup>1</sup>    |
| Print Speed                      | Up to 36 pages/minute (A4 size) <sup>1</sup>                            |
| First Print Time <sup>2</sup>    | Less than 8.5 seconds at 23 °C / 230 V                                  |

<sup>1</sup> The print speed may vary depending on the type of document you print.

<sup>2</sup> From Ready mode and standard tray

## Direct Print feature

|                      |   |
|----------------------|---|
| <b>Model</b>         | <b>DCP-8110DN</b>   |
| <b>Compatibility</b> | PDF version 1.7 <sup>1</sup> , JPEG, Exif + JPEG, PRN (created by Brother printer driver), TIFF (scanned by all Brother MFC or DCP models), XPS version 1.0 |
| <b>Interface</b>     | USB direct interface  |

<sup>1</sup> PDF data including a JBIG2 image file, a JPEG2000 image file or a transparency file is not supported.

# Computer requirements

| Minimum System Requirements and Supported PC Software Functions |  |  |                                |                                |                            |                  |                                 |  |
|---|--|--|--------------------------------|--------------------------------|----------------------------|------------------|---------------------------------|--|
| Computer Platform & Operating System Version                    |  | Processor Minimum Speed  | Minimum RAM                    | Recommended RAM                | Hard Disk Space to install |                  | Supported PC Software Functions | Supported PC Interface <sup>2</sup>        |
|   |  |  |                                |                                | For Drivers                | For Applications |                                 |  |
| Windows <sup>®</sup> Operating System                           | Windows <sup>®</sup> XP Home <sup>1 3</sup><br>Windows <sup>®</sup> XP Professional <sup>1 3</sup> | Intel <sup>®</sup> Pentium <sup>®</sup> II or equivalent   | 128 MB                         | 256 MB                         | 150 MB                     | 500 MB           | Printing, Scanning              | USB,<br>10Base-T/<br>100Base-TX (Ethernet) |
|   | Windows <sup>®</sup> XP Professional x64 Edition <sup>1 3</sup>                                    | 64-bit (Intel <sup>®</sup> 64 or AMD64) supported CPU  | 256 MB                         | 512 MB                         |                            |                  |                                 |  |
|   | Windows Vista <sup>®</sup> <sup>1 3</sup>  | Intel <sup>®</sup> Pentium <sup>®</sup> 4 or equivalent<br>64-bit (Intel <sup>®</sup> 64 or AMD64) supported CPU | 512 MB                         | 1 GB                           | 500 MB                     | 1.2 GB           |                                 |  |
|   | Windows <sup>®</sup> 7 <sup>1 3</sup>  | Intel <sup>®</sup> Pentium <sup>®</sup> 4 or equivalent<br>64-bit (Intel <sup>®</sup> 64 or AMD64) supported CPU | 1 GB (32-bit)<br>2 GB (64-bit) | 1 GB (32-bit)<br>2 GB (64-bit) | 650 MB                     |                  |                                 |  |

| Minimum System Requirements and Supported PC Software Functions |  |                                |             |                 |                            |                  |                                 |   |  |
|---|--|--------------------------------|-------------|-----------------|----------------------------|------------------|---------------------------------|---|--|
| Computer Platform & Operating System Version                    | Processor                                | Minimum Speed                  | Minimum RAM | Recommended RAM | Hard Disk Space to install |                  | Supported PC Software Functions | Supported PC Interface <sup>2</sup>           |  |
|   |  |                                |             |                 | For Drivers                | For Applications |                                 |   |  |
| Windows Server®<br>2003<br>(print only via network)             | Intel® Pentium® III or equivalent        |                                | 256 MB      | 512 MB          | 50 MB                      | N/A              | Printing                        | 10Base-T/<br>100Base-TX<br>(Ethernet)         |  |
|   | 64-bit (Intel®64 or AMD64) supported CPU |                                |             |                 |                            |                  |                                 |   |  |
|   | Intel® Pentium® 4 or equivalent          | 512 MB                         | 2 GB        |                 |                            |                  |                                 |   |  |
|   | 64-bit (Intel®64 or AMD64) supported CPU |                                |             |                 |                            |                  |                                 |   |  |
| Macintosh Operating System                                      | Mac OS X 10.5.8                          | PowerPC G4/G5 Intel® Processor | 512 MB      | 1 GB            | 80 MB                      | 400 MB           | Printing, Scanning              | USB,<br>10Base-T/<br>100Base-TX<br>(Ethernet) |  |
|   | Mac OS X 10.6.x                          | Intel® Processor               | 1 GB        | 2 GB            |                            |                  |                                 |   |  |
|   | Mac OS X 10.7.x                          | Intel® Processor               | 2 GB        | 2 GB            |                            |                  |                                 |   |  |

<sup>1</sup> For WIA, 1200 x 1200 resolution. Brother Scanner Utility enables to enhance up to 19200 x 19200 dpi.

<sup>2</sup> Third-party USB ports are not supported.

<sup>3</sup> Nuance™ PaperPort™ 12SE supports Microsoft® SP3 or higher for Windows® XP and SP2 or higher for Windows Vista® and Windows® 7.

For the latest driver updates, visit <http://solutions.brother.com/>.

All trademarks, brand and product names are property of their respective companies.

## Consumable items

| Model           |            | DCP-8110DN  | Model Name |
|-----------------|------------|---|------------|
| Toner Cartridge | Inbox      | Approx. 2,000 pages A4 or Letter page <sup>1</sup>                  | -          |
|                 | Standard   | Approx. 3,000 pages A4 or Letter page <sup>1</sup>                  | TN-3330    |
|                 | High Yield | Approx. 8,000 pages A4 or Letter page <sup>1</sup>                  | TN-3380    |
| Drum Unit       |            | Approx. 30,000 pages A4 or Letter pages (1 page / job) <sup>2</sup> | DR-3300    |

<sup>1</sup> Approx. cartridge yield is declared in accordance with ISO/IEC 19752.

<sup>2</sup> Drum life is approximate and may vary by type of use.



# Interfaces

| Model                        | DCP-8110DN   |
|------------------------------|--|
| <b>USB</b>                   | Hi-Speed USB 2.0 <sup>1 2</sup><br>It is recommended you use a USB 2.0 cable (Type A/B) that is no more than 6 feet (2 metres) long. |
| <b>Ethernet</b> <sup>3</sup> | 10BASE-T / 100BASE-TX<br>Use an Ethernet U/UTP cable category 5 or greater.  |

<sup>1</sup> Your machine has a Hi-Speed USB 2.0 interface. The machine can also be connected to a computer that has a USB 1.1 interface.

<sup>2</sup> Third-party USB ports are not supported.

<sup>3</sup> For detailed network specifications, see *Network (LAN)* >> page 122 and >>> Network User's Guide.

# Network (LAN)



## Note

For more information about the Network specifications ►► the Network User's Guide.

| Model              |       | DCP-8110DN  |
|--------------------|-------|---|
| LAN                |       | You can connect your machine to a network for Network Printing and Network Scanning.<br><br>Also included is Brother BRAdmin Light <sup>1 2</sup> Network Management software.  |
| Protocols          | IPv4  | ARP, RARP, BOOTP, DHCP, APIPA (Auto IP), WINS/NetBIOS name resolution, DNS Resolver, mDNS, LLNMR responder, LPR/LPD, Custom Raw Port/Port9100, SMTP Client, IPP/IPPS, FTP Client and Server, CIFS Client, TELNET Server, SNMPv1/v2c/v3, HTTP/HTTPS server, TFTP client and server, ICMP, Web Services (Print/Scan), SNTP Client |
|                    | IPv6  | NDP, RA, DNS resolver, mDNS, LLNMR responder, LPR/LPD, Custom Raw Port/Port9100, IPP/IPPS, FTP Client and Server, CIFS Client, TELNET Server, SNMPv1/v2c/v3, HTTP/HTTPS server, TFTP client and server, SMTP Client, ICMPv6, SNTP Client, Web Services (Print/Scan)   |
| Security Protocols | Wired | APOP, POP before SMTP, SMTP-AUTH, SSL/TLS (IPPS, HTTPS, SMTP, POP), SNMP v3, 802.1x (EAP-MD5, EAP-FAST, PEAP, EAP-TLS, EAP-TTLS), Kerberos  |

- <sup>1</sup> (For Windows® users) Brother BRAdmin Light is available on the CD-ROM provided with the machine.  
(For Macintosh users) Brother BRAdmin Light is available as a download from <http://solutions.brother.com/>.
- <sup>2</sup> (For Windows® users) If you require more advanced machine management, use the latest Brother BRAdmin Professional utility version that is available as a download from <http://solutions.brother.com/>.

# E

# Index

## A

- ADF (automatic document feeder)
  - using .....24
- Apple Macintosh
  - See Software User's Guide.

## C

- Cleaning
  - corona wire .....53
  - drum unit .....55
  - scanner .....52
- Consumable items ..... 38, 39
- Control panel overview .....6
- ControlCenter2 (for Macintosh)
  - See Software User's Guide.
- ControlCenter4 (for Windows®)
  - See Software User's Guide.
- Copy
  - keys .....6

## D

- Dimensions ..... 110
- Direct print .....27
  - Direct key .....28
  - specification ..... 117
- Document
  - how to load ..... 24, 25
- Drum unit
  - cleaning ..... 53, 55
  - replacing .....46

## E

- Envelopes .....14, 19, 20, 22
- Error messages on LCD .....62
  - No Paper .....64
  - Out of Memory .....65
  - Print Unable XX .....65
  - Scan Unable XX .....66

## F

- Folio ..... 17, 20

## G

- Greyscale ..... 115

## H

- HELP
  - LCD messages ..... 95
  - Menu Table ..... 96

## L

- Labels ..... 12, 19, 20, 23
- LCD (liquid crystal display) .....6, 95

## M

- Machine information
  - how to reset the machine ..... 94
  - reset functions ..... 94
  - serial number ..... 94
  - status LED ..... 8
- Macintosh
  - See Software User's Guide.
- Maintenance, routine ..... 51
  - replacing
    - drum unit ..... 46
    - toner cartridge ..... 40
- Memory ..... 110
- Menu Table ..... 96
- Mode, entering
  - copy .....26
  - scan ..... 7

## N

- Network
  - printing
    - See Network User's Guide.
  - scanning
    - See Software User's Guide.
- Network connectivity ..... 121
- Nuance™ PaperPort™ 12SE
  - See Software User's Guide. See also Help in the Nuance™ PaperPort™ 12SE application to access How-to-Guides.

## O

---

Out of Memory message .....65

## P

---

Paper .....19  
  how to load .....10  
  in multi-purpose tray .....12  
  in paper tray .....10  
  recommended .....19, 20  
  size .....17, 19  
  tray capacity .....20  
  type .....17, 19

Presto! PageManager  
  See Software User's Guide. See also Help  
  in the Presto! PageManager application.

Print  
  difficulties .....81  
  document from your computer .....31  
  drivers .....116  
  quality .....87  
  resolution .....116  
  specifications .....116

Printing  
  See Software User's Guide.

Programming your machine .....95

## Q

---

Quality  
  printing .....87

## R

---

Replacing  
  drum unit .....46  
  toner cartridge .....40

Resolution  
  copy .....114  
  print .....116  
  scan .....115

## S

---

Scan a document to a computer .....32

Scanner glass  
  using .....25

Scanning  
  See Software User's Guide.

Secure Print key .....7

Serial number  
  how to find  
  See inside front cover

Status LED .....8

## T

---

Text, entering .....108

Toner cartridge  
  replacing .....40

Troubleshooting .....81

  document jam .....68, 69

  error messages on LCD .....62

  if you are having difficulty  
    copy quality .....84

    network .....85

    paper handling .....83

    print quality .....87

    printing .....81

    scanning .....84

    software .....84

  maintenance messages on LCD .....62

  paper jam .....70, 71, 72, 75, 79

## V

---

Volume, setting  
  beeper .....9

## W

---

Weights .....110

Windows®  
  See Software User's Guide.

**brother**<sup>®</sup>

**Visit us on the World Wide Web**  
**<http://www.brother.com/>**

This machine is approved for use in the country of purchase only. Local Brother companies or their dealers will only support machines purchased in their own countries.

## Free Manuals Download Website

<http://myh66.com>

<http://usermanuals.us>

<http://www.somanuals.com>

<http://www.4manuals.cc>

<http://www.manual-lib.com>

<http://www.404manual.com>

<http://www.luxmanual.com>

<http://aubethermostatmanual.com>

Golf course search by state

<http://golfingnear.com>

Email search by domain

<http://emailbydomain.com>

Auto manuals search

<http://auto.somanuals.com>

TV manuals search

<http://tv.somanuals.com>