

**brother**<sup>®</sup>

# Basic User's Guide

MFC-9140CDN  
MFC-9340CDW

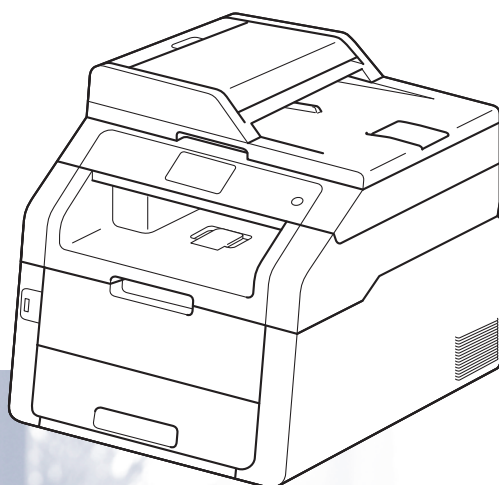

Version 0

CHN-ENG

## **To create a better environment**

Please cooperate

Firstly, thank you very much indeed for using our Brother products!

Brother focuses on the earth environment concerned. And make a basic policy which is to concern about the earth environment, including any workflow from product development to discard. The local citizen should be responsible for local society and its environment during these environment protection activities.

Therefore, we hope you'll take part in this environment plan, and pay attention to environment protection points as below while discarding used consumables.

- 1 Please deliver the used package materials to relevant waste disposal office for recycle.
- 2 When you discard used consumables, please follow and carry on relevant local regulations properly.
- 3 When the machine need replacing parts for the maintenance and repair, please discard used circuit boards, used electrical parts and products as disposed electrical materials.
- 4 The power consumption is 0 W after you turn off the machine and unplug it from the AC outlet.
- 5 Some parts in the machine can be used on the same series model machines which are produced in the same factory.

Note: If you want to replace the parts, please contact Brother Authorize Service Centers.

## **CHINA ENVIRONMENTAL LABELLING NOTICE**

- 1 Machines with an LWAd > 63.0 dB(A) are recommended to be set up in separate rooms due to their noise emissions.
- 2 The machine can use recycled paper.
- 3 Ensure that during use the machine is used in a well ventilated area.
- 4 Brother will accept machines and consumables for recycling. For details of the return scheme please refer to the webpage <http://www.brother.cn/company/info/declaration/20090304.html>.

# User's Guides and where do I find them?

Which Guide?	What's in it?	Where is it?
<b>Product Safety Guide</b>	Read this Guide first. Read the Safety Instructions before you set up your machine. See this Guide for trademarks and legal limitations.	For Chinese: Printed / In the box  For English: PDF file / CD-ROM / In the box
<b>Quick Setup Guide</b>	Follow the instructions for setting up your machine and installing the drivers and software for the operating system and connection type you are using.	For Chinese: Printed / In the box  For English: PDF file / CD-ROM / In the box
<b>Basic User's Guide</b>	Learn the basic Fax, Copy, Scan and Direct Print operations and how to replace consumables. See troubleshooting tips.	For Chinese: Printed / In the box  For English: PDF file / CD-ROM / In the box
<b>Advanced User's Guide</b>	Learn more advanced operations: Fax, Copy, security features, printing reports and performing routine maintenance.	PDF file / CD-ROM / In the box
<b>Software User's Guide</b>	Follow these instructions for Printing, Scanning, Network Scanning, Remote Setup, PC-Fax, and using the Brother ControlCenter utility.	HTML file / CD-ROM / In the box
<b>Network User's Guide</b>	This Guide provides useful information about wired and wireless network settings and security settings using the Brother machine. You can also find supported protocol information for your machine and detailed troubleshooting tips.	PDF file / CD-ROM / In the box
<b>Wi-Fi Direct™ Guide</b> (MFC-9340CDW)	This Guide provides details on how to configure and use your Brother machine for wireless printing directly from a mobile device supporting the Wi-Fi Direct™ standard.	PDF file / Brother Solutions Center <sup>1</sup>
<b>Google Cloud Print Guide</b>	This Guide provides details on how to configure your Brother machine to a Google account and use Google Cloud Print services for printing over the Internet.	PDF file / Brother Solutions Center <sup>1</sup>
<b>Mobile Print/Scan Guide for Brother iPrint&amp;Scan</b>	This Guide provides useful information about printing from your mobile device and scanning from your Brother machine to your mobile device when connected on a Wi-Fi network.	PDF file / Brother Solutions Center <sup>1</sup>

Which Guide?	What's in it?	Where is it?
<b>AirPrint Guide</b>	This Guide provides information for using AirPrint to print from OS X v10.7.x, 10.8.x and your iPhone, iPod touch, iPad, or other iOS device to your Brother machine without installing a printer driver.	PDF file / Brother Solutions Center <sup>1</sup>

<sup>1</sup> Visit us at <http://solutions.brother.com/>.

# Table of Contents

## (Basic User's Guide)

<b>1</b>	<b>General information</b>	<b>1</b>
	Using the documentation.....	1
	Symbols and conventions used in the documentation .....	1
	Accessing Brother Utilities (Windows® 8).....	2
	Accessing the Advanced User's Guide, Software User's Guide and Network User's Guide.....	3
	Viewing Documentation.....	3
	How to access the User's Guides for Advanced Features .....	5
	Accessing Brother Support (Windows®).....	6
	Accessing Brother Support (Macintosh).....	6
	Control panel overview.....	8
	Touchscreen LCD.....	10
	Setting the Ready screen .....	13
	Basic Operations .....	14
	Shortcut Settings .....	15
	Adding Copy Shortcuts.....	15
	Adding Fax Shortcuts .....	15
	Adding Scan Shortcuts.....	16
	Changing Shortcuts.....	18
	Editing Shortcut Names.....	19
	Deleting Shortcuts .....	19
	Recalling Shortcuts.....	19
	Volume settings.....	20
	Ring volume.....	20
	Beeper volume .....	20
	Speaker volume.....	20
<b>2</b>	<b>Loading paper</b>	<b>21</b>
	Loading paper and print media.....	21
	Loading paper in the paper tray.....	21
	Loading paper in the manual feed slot .....	23
	Unscannable and unprintable areas.....	27
	Paper settings.....	28
	Paper Size .....	28
	Paper Type.....	28
	Acceptable paper and other print media.....	29
	Recommended paper and print media .....	29
	Type and size of paper .....	29
	Handling and using special paper .....	31
<b>3</b>	<b>Loading documents</b>	<b>34</b>
	How to load documents.....	34
	Using the automatic document feeder (ADF) .....	34
	Using the scanner glass .....	35

<b>4</b>	<b>Sending a fax</b>	<b>36</b>
	How to send a fax .....	36
	Stop faxing.....	37
	Faxing Letter size documents from the scanner glass .....	37
	Cancelling a fax in process.....	37
	Transmission Verification Report.....	38
<b>5</b>	<b>Receiving a fax</b>	<b>39</b>
	Receive modes .....	39
	Using receive modes .....	40
	Receive Mode settings .....	41
	Ring Delay .....	41
	F/T Ring Time (Fax/Tel mode only).....	41
	Fax Detect .....	42
	Fax Preview (Black and White only) .....	43
	How to preview a received fax.....	43
	Turning off Fax Preview.....	45
<b>6</b>	<b>Using PC-FAX</b>	<b>46</b>
	How to use PC-FAX.....	46
	PC-Fax Receive (For Windows® only) .....	46
	PC-FAX Send .....	47
<b>7</b>	<b>Telephone and external devices</b>	<b>48</b>
	Connecting an external TAD .....	48
	Connections.....	48
	Recording an outgoing message (OGM) .....	49
	Multi-line connections (PABX) .....	49
	External and extension telephones.....	50
	Connecting an external or extension telephone .....	50
	Operation from external or extension telephones.....	50
	For Fax/Tel mode only.....	50
	Using a non-Brother cordless external handset .....	51
	Using Remote Codes .....	51
<b>8</b>	<b>Dialling and storing numbers</b>	<b>53</b>
	How to dial .....	53
	Manual dialling.....	53
	Dialling from the Address Book .....	53
	Fax redial .....	53
	Tone or Pulse .....	54
	Storing numbers .....	54
	Storing a pause .....	54
	Storing Address Book numbers.....	54
	Changing Address Book names or numbers.....	55

<b>9</b>	<b>Making copies</b>	<b>57</b>
	How to copy.....	57
	Stop copying.....	57
	Copy preset settings.....	57
	Copy Options.....	58
<b>10</b>	<b>Printing data from a USB Flash memory drive or digital camera supporting mass storage (For MFC-9340CDW)</b>	<b>59</b>
	Creating a PRN file for direct printing.....	59
	Printing data directly from the USB Flash memory drive or digital camera supporting mass storage.....	60
	Changing the default settings for direct print.....	62
<b>11</b>	<b>How to print from a computer</b>	<b>63</b>
	Printing a document.....	63
<b>12</b>	<b>How to scan to a computer</b>	<b>64</b>
	Before scanning.....	64
	Scanning a document as a PDF file using ControlCenter4 (Windows®).....	65
	How to scan a document as a PDF file using the Touchscreen.....	67
<b>A</b>	<b>Routine maintenance</b>	<b>69</b>
	Replacing the consumable items.....	69
	Replacing the toner cartridges.....	73
	Replacing the drum units.....	80
	Replacing the belt unit.....	86
	Replacing the waste toner box.....	90
	Cleaning and Checking the machine.....	95
	Cleaning the outside of the machine.....	96
	Cleaning the LED heads.....	97
	Cleaning the scanner glass.....	98
	Cleaning the corona wires.....	99
	Cleaning the drum unit.....	102
	Cleaning the paper pick-up rollers.....	108
	Calibration.....	109
	Auto Registration.....	110
	Frequency (Colour Correction).....	111

<b>B</b>	<b>Troubleshooting</b>	<b>112</b>
	Identifying your problem .....	112
	Error and maintenance messages .....	114
	Transferring your faxes or Fax Journal report .....	122
	Document Jams .....	124
	Document is jammed in the top of the ADF unit .....	124
	Document is jammed under the document cover .....	124
	Removing small documents jammed in the ADF .....	125
	Document is jammed at the output tray .....	125
	Paper Jams .....	126
	Paper is jammed in the manual feed slot .....	126
	Paper is jammed in the paper tray .....	126
	Paper is jammed at the output paper tray .....	127
	Paper is jammed at the back of the machine .....	128
	Paper is jammed inside the machine .....	130
	Paper is jammed underneath the paper tray .....	133
	If you are having difficulty with your machine .....	135
	Setting Dial Tone detection .....	144
	Telephone line interference / VoIP .....	144
	Improving the print quality .....	145
	Machine Information .....	155
	Checking the Serial Number .....	155
	Checking the Firmware Version .....	155
	Reset functions .....	156
	How to reset the machine .....	156
<b>C</b>	<b>Settings and features tables</b>	<b>157</b>
	Using the Settings Tables .....	157
	Settings Tables .....	158
	Features Tables .....	179
	Entering text .....	204
<b>D</b>	<b>Specifications</b>	<b>206</b>
	General .....	206
	Document Size .....	208
	Print media .....	209
	Fax .....	210
	Copy .....	211
	Scanner .....	212
	Printer .....	213
	Interfaces .....	214
	Network .....	215
	Direct Print feature .....	216
	Computer requirements .....	217
	Consumable items .....	218
<b>E</b>	<b>Index</b>	<b>219</b>



# Table of Contents

## (Advanced User's Guide)

You can view the Advanced User's Guide on the CD-ROM.

The Advanced User's Guide explains the following features and operations.

### **1 General Setup**

---

*Memory storage*

*Ecology features*

*Touchscreen*

*Dial Prefix*

### **2 Security features**

---

*Secure Function Lock 2.0*

*Setting Lock*

*Dial Restriction*

### **3 Sending a fax**

---

*Additional sending options*

*Additional sending operations*

*Polling*

### **4 Receiving a fax**

---

*Memory Receive Options*

*Remote retrieval*

*Additional receiving operations*

*Polling*

### **5 Dialling and storing numbers**

---

*Telephone line services*

*Additional dialling operations*

*Additional ways to store numbers*

### **6 Printing reports**

---

*Fax reports*

*Reports*

### **7 Making copies**

---

*Copy settings*

### **A Routine maintenance**

---

*Checking the machine*

*Replacing periodic maintenance parts*

*Packing and shipping the machine*

### **B Glossary**

---

### **C Index**

---

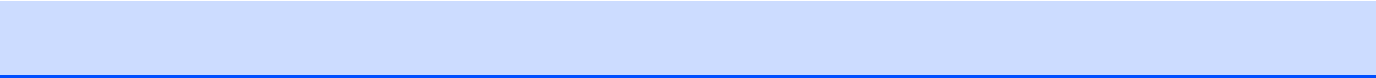

## Using the documentation

Thank you for buying a Brother machine! Reading the documentation will help you make the most of your machine.

## Symbols and conventions used in the documentation

The following symbols and conventions are used throughout the documentation.

### **WARNING**

WARNING indicates a potentially hazardous situation which, if not avoided, could result in death or serious injuries.

### **IMPORTANT**

IMPORTANT indicates a potentially hazardous situation which, if not avoided, may result in damage to property or loss of product functionality.

### **NOTE**

Notes tell you how you should respond to a situation that may arise or give tips about how the current operation works with other features.



Electrical Hazard icons alert you to a possible electrical shock.



Fire Hazard icons alert you to the possibility of fire.



Hot Surface icons warn you not to touch machine parts that are hot.



Prohibition icons indicate actions that must not be performed.

**Bold** Bold style identifies the dial pad numbers of the Touchpanel or on the computer screen.

*Italics* Italicized style emphasizes an important point or refers you to a related topic.

`Courier New` Courier New font identifies the messages shown on the Touchscreen of the machine.

Follow all warnings and instructions marked on the product.

### **NOTE**

Most of the illustrations in this User's Guide show the MFC-9340CDW.

## Accessing Brother Utilities (Windows® 8)

If you are using a tablet running Windows® 8, you can make your selections either by tapping the screen or by clicking with your mouse.

After the printer driver is installed,  appears on both the Start screen and the desktop.

- 1 Tap or click **Brother Utilities** either on the Start screen or the desktop.

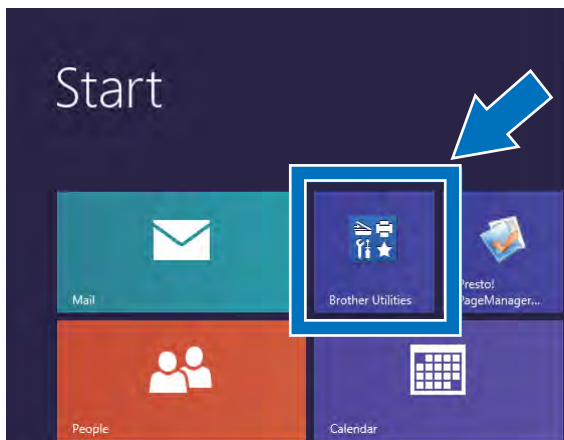

- 2 Select your machine.

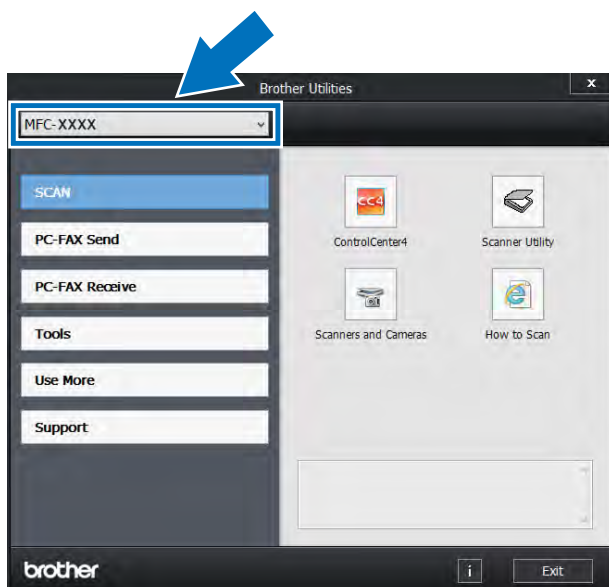

- 3 Choose the function you want to use.

# Accessing the Advanced User's Guide, Software User's Guide and Network User's Guide

This Basic User's Guide does not contain all the information about the machine such as how to use the advanced features for Fax, Copy, Printer, Scanner, PC-Fax and Network. When you are ready to learn detailed information about these operations, read the **Advanced User's Guide**, **Software User's Guide** in HTML format and **Network User's Guide** that are on the CD-ROM.

## Viewing Documentation

### Viewing Documentation (Windows®)

(Windows® 7 / Windows Vista® /  
Windows® XP / Windows Server® 2008 R2 /  
Windows Server® 2008 /  
Windows Server® 2003)

To view the documentation, from the  (**Start**) menu, select **All programs > Brother > MFC-XXXX** (where XXXX is your model name) from the programs list, and then choose **User's Guides**.

(Windows® 8 / Windows Server® 2012)

Click  (**Brother Utilities**), and then click the drop-down list and select your model name (if not already selected). Click **Support** in the left navigation bar, and then click **User's Guides**.

If you have not installed the software, you can find the documentation on the CD-ROM by following these steps:

- 1 Turn on your computer. Insert the CD-ROM into your CD-ROM drive.

### NOTE

If the Brother screen does not appear, go to **Computer (My Computer)**. (For Windows® 8: Click  (File Explorer) on the taskbar, and then go to **Computer**.) Double-click the CD-ROM icon, and then double-click **start.exe**.

- 2 If the model name screen appears, click your model name.
- 3 If the language screen appears, click your language. The CD-ROM Top Menu appears.



- 4 Click **User's Guides**.
- 5 Click **PDF/HTML documents**. If the country screen appears, select your country. After the list of User's Guides appears, select the Guide you want.

## Viewing Documentation (Macintosh)

- 1 Turn on your Macintosh. Insert the CD-ROM into your CD-ROM drive. Double-click the **BROTHER** icon. The following window will appear.



- 2 Double-click the **User's Guides** icon.
- 3 Select your model and language if needed.
- 4 Click **User's Guides**.
- 5 After the list of User's Guides appears, select the Guide you want.

## How to find Scanning instructions

There are several ways you can scan documents. You can find the instructions as follows:

### Software User's Guide

- *Scanning*
- *ControlCenter*
- *Network Scanning*

### Presto! PageManager User's Guide

#### NOTE

- Presto! PageManager must be installed before use.
  - (Macintosh users) Presto! PageManager must be downloaded and installed before use (for further instructions, see *Accessing Brother Support (Macintosh)* on page 6).
- 
- The complete Presto! PageManager User's Guide can be viewed from the Help section in the Presto! PageManager application.

## How to find Network setup instructions

Your machine can be connected to a wireless (MFC-9340CDW only) or wired network.

- Basic setup instructions:  
(see Quick Setup Guide.)
- Connection to a wireless access point or router supports Wi-Fi Protected Setup or AOSS™:  
(see Quick Setup Guide.)
- More information about network setup:  
(see Network User's Guide.)

## How to access the User's Guides for Advanced Features

You can view and download these Guides from the Brother Solutions Center at:

<http://solutions.brother.com/>

Click **Manuals** on your model's page to download the documentation.

### Wi-Fi Direct™ Guide

(MFC-9340CDW)

This Guide provides information about how to configure and use your Brother machine for wireless printing directly from a mobile device supporting the Wi-Fi Direct™ standard.

### Google Cloud Print Guide

This Guide provides information about how to configure your Brother machine to a Google account and use Google Cloud Print services for printing over the Internet.

### Mobile Print/Scan Guide for Brother iPrint&Scan

This Guide provides useful information about printing from your mobile device and scanning from your Brother machine to your mobile device when connected on a Wi-Fi network.

### AirPrint Guide

This Guide provides information for using AirPrint to print from OS X v10.7.x, 10.8.x and your iPhone, iPod touch, iPad, or other iOS device to your Brother machine without installing a printer driver.

## Accessing Brother Support (Windows®)

You can find all the contacts you will need, such as web support (Brother Solutions Center) on the CD-ROM.

- Click **Brother Support** on the **Top Menu**. The Brother Support screen appears.

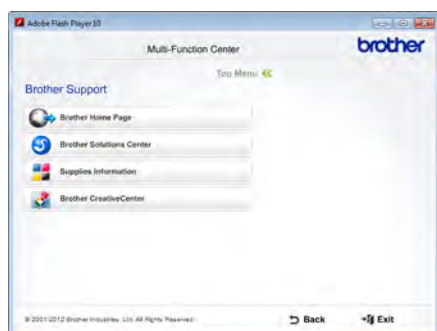

- To access our website, click **Brother Home Page**.
- For the latest news and product support information, click **Brother Solutions Center**.
- To visit our website for original Brother Supplies, click **Supplies Information**.
- To access the Brother CreativeCenter for FREE photo projects and printable downloads, click **Brother CreativeCenter**.
- To return to the **Top Menu**, click **Back** or if you have finished, click **Exit**.

## Accessing Brother Support (Macintosh)

You can find all the contacts you will need, such as web support (Brother Solutions Center) on the CD-ROM.

- Double-click the **Brother Support** icon. Choose your model if needed. The Brother Support screen appears.

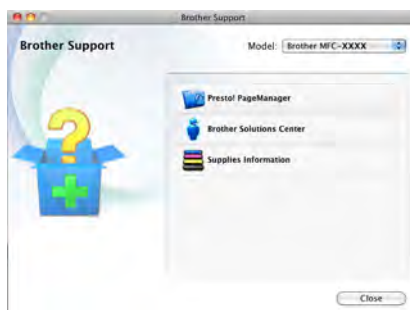

- To download and install Presto! PageManager, click **Presto! PageManager**.
- For the latest news and product support information, click **Brother Solutions Center**.
- To visit our website for original Brother Supplies, click **Supplies Information**.





## Control panel overview

The MFC-9140CDN and MFC-9340CDW have a 3.7 in. (93.4 mm) Touchscreen LCD and Touchpanel <sup>1</sup>.

<sup>1</sup> This is a Touchscreen LCD with an electrostatic Touchpanel that only shows the LEDs that can be used.



### NOTE

The illustrations are based on MFC-9340CDW

#### 1 3.7 in. (93.4 mm) Touchscreen LCD (Liquid Crystal Display)

This is a Touchscreen LCD. You can access the menus and options by pressing them when they are displayed on this screen.



## 2 Touchpanel:

The LEDs on the Touchpanel only light up when they are available for use.

### ■ Back

Press to go back to the previous menu level.

### ■ Home

Press to return to the Home screen. The factory setting shows the date and time, but you can change the Home screen's default setting (see *Setting the Ready screen* on page 13.)

### ■ Cancel

Press to cancel an operation when illuminated red.

### ■ Dial Pad

Press the numbers on the Touchpanel to dial telephone and fax numbers or to enter the number of copies.

## 3 Power On/Off

Press  to turn on the machine.

Press and hold down  to turn off the machine. The Touchscreen LCD will show *Shutting Down* and will stay on for a few seconds before going off.

## 4 (MFC-9340CDW)

The Wi-Fi light is on when the network interface is WLAN.

## Touchscreen LCD

You can select three types of screens for the Home screen. When the Home screen is displayed, you can change the displayed screen by swiping left or right, or pressing ◀ or ▶.

The following screens show the machines status when the machine is idle.

	<p><b>Home screen</b></p> <p>The Home screen shows the date and time and provides access to Fax, Copy, Scan, Wi-Fi setup, Toner levels and the Setup screen.</p> <p>When the Home screen is displayed the machine is in Ready mode. When Secure Function Lock <sup>1</sup> is turned on an icon will be displayed.</p> <p><sup>1</sup> See Advanced User's Guide, <i>Secure Function Lock 2.0</i>.</p>
	<p><b>More screen</b></p> <p>The More screen provides access to additional features, such as Secure Print, 2 in 1 ID Copy and USB.</p>
	<p><b>Shortcut screens</b></p> <p>You can quickly create a Shortcut for frequently used functions, such as sending a fax, making a copy and scanning (for more information, see <i>Shortcut Settings</i> on page 15).</p>

**NOTE**

Swiping is a type of user operation on the Touchscreen that is performed by brushing your finger across the screen to display the next page or item.

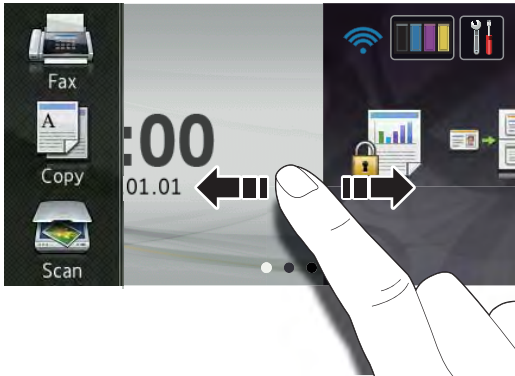
**1 Modes:**

- Fax  
Lets you access Fax mode.
- Copy  
Lets you access Copy mode.
- Scan  
Lets you access Scan mode.

**2 Wireless Status**

(MFC-9340CDW)

A four-level indicator on the Ready mode screen shows the current wireless signal strength if you are using a wireless connection.



If you see **WIFI** at the top on the screen, you can easily configure the wireless settings by pressing it (for more information, see Quick Setup Guide).

**3 (Toner)**

See the remaining toner life.  
Press to access the Toner menu.

**NOTE**

The indication of remaining toner life will vary depending on the types of documents printed and customer's usage.

**4 (Settings)**

Press to access the main settings (for more information, see *Settings screen* on page 12).

**5 Date and Time**

See the date and time that has been set in the machine.

**6 Secure Print**

Lets you access the secure print menu.

**7 2 in 1 ID Copy**

Lets you access the 2 in 1 ID copy preset.

**8 USB**

Press to access the Direct Print and Scan to USB menus.

**9 Shortcuts**

Press to set up Shortcuts.

You can quickly copy, scan, and send a fax using the options set as Shortcuts.

**NOTE**

- Three Shortcut screens are available. You can set up to six Shortcuts in each Shortcut screen. A total of 18 Shortcuts are available.
- Swipe left or right, or press ◀ or ▶, to view the other Shortcut screens.

## 10 New Fax

When Fax Preview is set to On, you can see how many new faxes you received into the memory.



## 11 Warning icon !

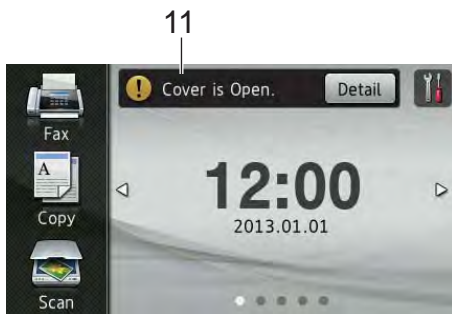

The warning icon ! appears when there is an error or maintenance message; press Detail to view it, and then press  to return to Ready mode.

For details, see *Error and maintenance messages* on page 114.

## NOTE

- This product adopts the font of ARPHIC TECHNOLOGY CO.,LTD.
- MascotCapsule UI Framework and MascotCapsule Tangiblet developed by HI CORPORATION are used. MascotCapsule is a registered trademark of HI CORPORATION in Japan.



## Settings screen

The Touchscreen shows the machines settings when you press .

You can check and access all the machine's settings from the following screen.

### (MFC-9340CDW)



### (MFC-9140CDN)



### 1 Toner

See the remaining toner life.

Press to access the Toner menu.

### 2 Receive Mode

See the current Receive Mode.

- Fax Auto
- Fax/Tel
- External TAD
- Manual

**3 Network**

Press to set up a network connection.

(MFC-9340CDW)

A four level indicator on the screen shows the current wireless signal strength if you are using a wireless connection.

**4 Date & Time**

See the date and time.

Press to access the `Date & Time` menu.

**5 Fax Preview**

See the Fax Preview status.

Press to access the Fax Preview setting.

**6 All Settings**

Press to access the full settings menu.

**7 Tray Setting**

(MFC-9340CDW)

See the selected paper size. Press to change the paper size and paper type settings if needed.

**8 Wi-Fi Direct**

(MFC-9340CDW)

Press to set up a Wi-Fi Direct™ network connection.

**9 Paper Size**

(MFC-9140CDN)

Lets you check the current paper size. Also, lets you access the Paper Size setting.

**10 Paper Type**



(MFC-9140CDN)

Lets you check the current paper type. Also, lets you access the Paper Type setting.

**Setting the Ready screen**

Set the Ready screen to either `Home`, `More`, `Shortcuts 1`, `Shortcuts 2` or `Shortcuts 3`.

When the machine is idle or you press , the Touchscreen will return to the screen you set.

- 1 Press .
- 2 Press `All Settings`.
- 3 Swipe up or down, or press ▲ or ▼ to display `General Setup`.
- 4 Press `General Setup`.
- 5 Swipe up or down, or press ▲ or ▼ to display `Button Settings`.
- 6 Press `Button Settings`.
- 7 Press `Home Button Settings`.
- 8 Swipe up or down, or press ▲ or ▼ to display `Home`, `More`, `Shortcuts 1`, `Shortcuts 2` or `Shortcuts 3` and then press the option you want.
- 9 Press .  
The machine will go to your chosen Home screen.

## Basic Operations

Press your finger on the Touchscreen to operate it. To display and access all the screen menus or options, swipe left, right, up, down, or press ◀▶ or ▲▼ to scroll through them.

### IMPORTANT

DO NOT press the Touchscreen with a sharp object, such as a pen or stylus. It may damage the machine.

The following steps show how to change a setting in the machine. In this example, the Touchscreen Backlight setting is changed from Light to Med.

1 Press .

2 Press All Settings.

3 Swipe up or down, or press ▲ or ▼ to display General Setup.

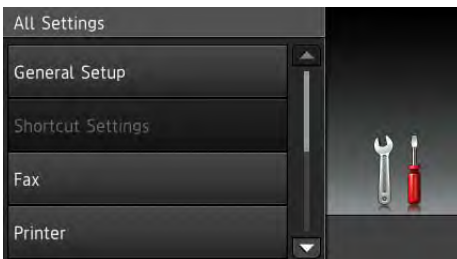

4 Press General Setup.

5 Swipe up or down, or press ▲ or ▼ to display LCD Settings.



6 Press LCD Settings.

7 Press Backlight.

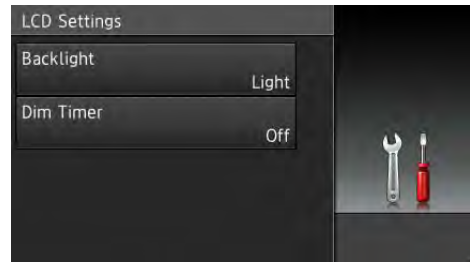

8 Press Med.

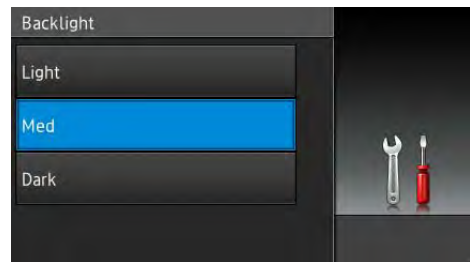

### NOTE

Press  to go back to the previous level.

9 Press .



## Shortcut Settings

You can add the fax, copy and scan settings you use most frequently by setting them as your Shortcuts. Later you can recall and apply these settings quickly and easily. You can add up to 18 Shortcuts.

### Adding Copy Shortcuts

The following settings can be included in a copy Shortcut:

- Quality
- Enlarge/Reduce
- Density
- Contrast
- Stack/Sort
- Page Layout
- Colour Adjust
- 2-sided Copy
- 2-sided Copy Page Layout (MFC-9340CDW)
- Remove Background Colour

- 1 If the displayed screen is either Home or More, swipe left or right, or press ◀ or ▶ to display a Shortcut screen.
- 2 Press  where you have not added a Shortcut.
- 3 Press Copy.
- 4 Read the information on the Touchscreen, and then confirm it by pressing OK.
- 5 Swipe up or down, or press ▲ or ▼ to display the copy presets, and then press the preset you want.
- 6 Swipe up or down, or press ▲ or ▼ to display the available settings, and then press the setting you want.

- 7 Swipe up or down, or press ▲ or ▼ to display the available options for the setting, and then press the option you want.  
Repeat steps 6 and 7 until you have selected all the settings for this Shortcut.
- 8 When you have finished changing the settings, press `Save as Shortcut`.
- 9 Read and confirm the displayed list of settings you selected, and then press OK.
- 10 Enter a name for the Shortcut using the keyboard on the Touchscreen. (To help you enter letters, see *Entering text* on page 204.)  
Press OK.
- 11 Press OK to save your Shortcut.

### Adding Fax Shortcuts

The following settings can be included in a fax Shortcut:

- Fax Resolution
- 2-sided Fax (MFC-9340CDW)
- Contrast
- Real Time TX
- Coverpage Setup
- Overseas Mode
- Grass Scan Size

- 1 If the displayed screen is either Home or More, swipe left or right, or press ◀ or ▶ to display a Shortcut screen.
- 2 Press  where you have not added a Shortcut.
- 3 Press Fax.
- 4 Read the information on the Touchscreen, and then confirm it by pressing OK.

- 5 Enter the fax or telephone number using the dial pad on the Touchpanel, the Address Book or the Call History on the Touchscreen. When you have finished, go to step 6.

## NOTE

- You can enter up to 20 digits for a fax number.
- If the Shortcut is to be used for broadcasting, press **Options** and select **Broadcasting** in step 7 before entering the fax or telephone number in step 5.
- You can enter up to 20 fax numbers if the Shortcut is for broadcasting. The fax numbers can be entered in any combination of Group numbers from the Address Book, individual fax numbers from the Address Book or entered manually (see *Advanced User's Guide, Broadcasting*).
- When you enter a fax number in a Shortcut, it will be added automatically to the Address Book. The name in the Address Book will be the Shortcut name plus a sequential number.

- 6 Press **Options**.
- 7 Swipe up or down, or press ▲ or ▼ to display the available settings, and then press the setting you want.
- 8 Press the option you want.
- Repeat steps 7 and 8 until you have selected all the settings for this Shortcut. Press **OK**.
- 9 When you have finished changing the settings, press **Save as Shortcut**.
- 10 Read and confirm the displayed list of settings you selected, and then press **OK**.

- 11 Enter a name for the Shortcut using the keyboard on the Touchscreen. (To help you enter letters, see *Entering text* on page 204.) Press **OK**.

- 12 Press **OK** to save your Shortcut.

## Adding Scan Shortcuts

The following settings can be included in a scan Shortcut:

to USB

- 2-sided Scan (MFC-9340CDW)
- Scan Type
- Resolution
- File Type
- Glass Scan Size
- File Name
- File Size
- Remove Background Colour

to E-mail Server (Available after IFAX is downloaded)

- 2-sided Scan (MFC-9340CDW)
- Scan Type
- Resolution
- File Type
- Glass Scan Size
- File Size

to OCR / to File / to Image / to E-mail

- PC Select

to FTP / to Network

- Profile Name

- 1 If the displayed screen is either Home or More, swipe left or right, or press ◀ or ▶ to display a Shortcut screen.
- 2 Press  where you have not added a Shortcut.
- 3 Press Scan.
- 4 Swipe up or down, or press ▲ or ▼ to display the type of scan you want, and then press it.
- 5 Do one of the following:
  - If you pressed to USB, read the information on the Touchscreen, and then press OK to confirm it. Go to step 8.
  - If you pressed to E-mail Server, read the information on the Touchscreen, and then press OK to confirm it. Go to step 6.
  - If you pressed to OCR, to File, to Image or to E-mail, read the information on the Touchscreen, and then press OK to confirm it. Go to step 7.
  - If you pressed to FTP or to Network, read the information on the Touchscreen, and then press OK to confirm it.
 

Swipe up or down, or press ▲ or ▼ to display the Profile Name, and then press it.

Press OK to confirm the Profile Name you have selected. Go to step 13.

## NOTE

To add a Shortcut for to Network and to FTP, you must have added the Profile Name beforehand.

- 6 Do one of the following:
  - To enter an E-mail address manually, press Manual. Enter the E-mail address using the keyboard on the Touchscreen. (To help you enter letters, see *Entering text* on page 204.)
 

Press OK.
  - To enter an E-mail address from the Address Book, press Address Book. Swipe up or down, or press ▲ or ▼ to display the E-mail address you want, and then press it.
 

Press OK.

After you confirm the E-mail address you entered, press OK. Go to step 8.

## NOTE

Press Detail to view the list of addresses you have entered.

- 7 Do one of the following:
  - When the machine is connected to a computer using a USB connection:
 

Press OK to confirm USB is selected as the PC Name. Go to step 16.
  - When the machine is connected to a network:
 

Swipe up or down, or press ▲ or ▼ to display the PC Name, and then press it. Press OK to confirm the PC Name you selected. Go to step 13.
- 8 Press Options.
- 9 Swipe up or down, or press ▲ or ▼ to display the available settings, and then press the setting you want.
- 10 Swipe up or down, or press ▲ or ▼ to display the available options for the setting, and then press the option you want.
 

Repeat steps 9 and 10 until you have selected all the settings for this Shortcut. Press OK.

- 11 Review the settings you have selected:
  - If you need to make additional changes, return to step 8.
  - If you are satisfied with your changes, press **Save as Shortcut**.
- 12 Review your settings on the Touchscreen, and then press **OK**.
- 13 Enter a name for the Shortcut using the keyboard on the Touchscreen. (To help you enter letters, see *Entering text* on page 204.) Press **OK**.
- 14 Read the information on the Touchscreen, and then press **OK** to save your Shortcut.

## Changing Shortcuts

---

You can change the settings in a Shortcut.

- 1 Press the Shortcut you want. The settings for the Shortcut that you chose are displayed.
- 2 Change the settings for the Shortcut you chose in step 1 (for more information, see *Shortcut Settings* on page 15).
- 3 When you have finished changing settings, press **Save as Shortcut**.
- 4 Press **OK** to confirm.
- 5 Do one of the following:
  - To overwrite the Shortcut, press **Yes**. Go to step 7.
  - If you do not want to overwrite the Shortcut, press **No** to enter a new Shortcut name. Go to step 6.
- 6 To create a new Shortcut, hold down  to delete the current name, and then enter a new name using the keyboard on the Touchscreen. (To help you enter letters, see *Entering text* on page 204.) Press **OK**.
- 7 Press **OK** to confirm.

## Editing Shortcut Names

You can edit a Shortcut name.

- 1 Press and hold the Shortcut until the dialog box appears.

### NOTE

You can also press , All Settings and Shortcut Settings.

- 2 Press `Edit Shortcut Name`.
- 3 To edit the name, hold down  to delete the current name, and then enter a new name using the keyboard on the Touchscreen. (To help you enter letters, see *Entering text* on page 204.) Press `OK`.

## Deleting Shortcuts

You can delete a Shortcut.

- 1 Press and hold the Shortcut until the dialog box appears.

### NOTE

You can also press , All Settings and Shortcut Settings.

- 2 Press `Delete` to delete the Shortcut that you chose in step 1.
- 3 Press `Yes` to confirm.

## Recalling Shortcuts



The Shortcut settings are displayed on the Shortcut screen. To recall a Shortcut, simply press the Shortcut name.

## Volume settings

### Ring volume

---

You can choose from a range of ring volume levels.

- 1 Press .
- 2 Press All Settings.
- 3 Swipe up or down, or press ▲ or ▼ to display General Setup.
- 4 Press General Setup.
- 5 Swipe up or down, or press ▲ or ▼ to display Volume.
- 6 Press Volume.
- 7 Press Ring.
- 8 Press Off, Low, Med or High.
- 9 Press .

### Beeper volume

---

When the beeper is on, the machine will beep when you press a key, make a mistake, or after you send or receive a fax. You can choose from a range of volume levels.



- 1 Press .
- 2 Press All Settings.
- 3 Swipe up or down, or press ▲ or ▼ to display General Setup.
- 4 Press General Setup.
- 5 Swipe up or down, or press ▲ or ▼ to display Volume.
- 6 Press Volume.

- 7 Press Beep.
- 8 Press Off, Low, Med or High.
- 9 Press .

### Speaker volume

---

You can choose from a range of speaker volume levels.

- 1 Press .
- 2 Press All Settings.
- 3 Swipe up or down, or press ▲ or ▼ to display General Setup.
- 4 Press General Setup.
- 5 Swipe up or down, or press ▲ or ▼ to display Volume.
- 6 Press Volume.
- 7 Press Speaker.
- 8 Press Off, Low, Med or High.
- 9 Press .

# 2

## Loading paper

### Loading paper and print media

The machine can feed paper from the paper tray or manual feed slot.

#### NOTE

If your application software supports paper size selection on the print menu, you can select it through the software. If your application software does not support it, you can set the paper size in the printer driver or by pressing the buttons on the Touchscreen.

### Loading paper in the paper tray

You can load up to 250 sheets in the paper tray. Paper can be loaded up to the maximum paper mark (▼▼▼) on the right side of the paper tray (for recommended paper, see *Acceptable paper and other print media* on page 29).

### Printing on plain paper, thin paper or recycled paper from the paper tray

- 1 Pull the paper tray completely out of the machine.

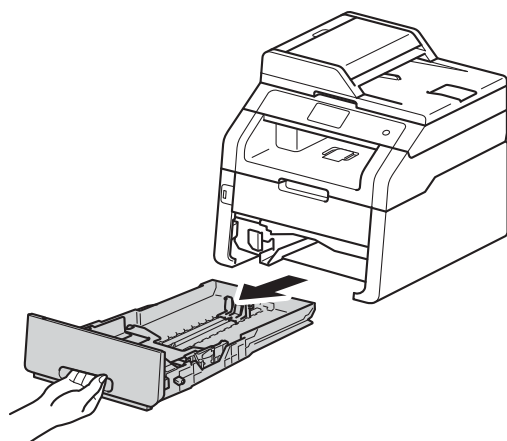

- 2 While pressing the green paper-guide release levers (1), slide the paper guides to fit the paper you are loading in the tray. Make sure the guides are firmly in the slots.

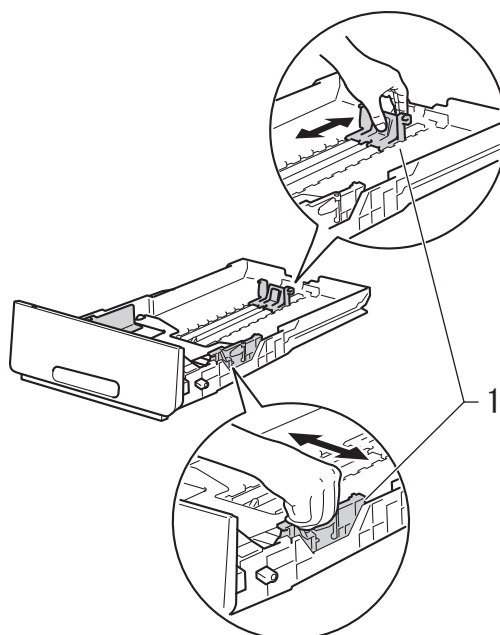

- 3 Fan the stack of paper well to avoid paper jams and misfeeds.

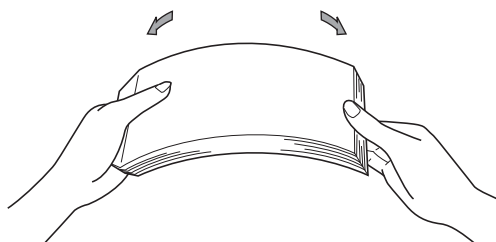

- 4 Load paper in the tray and make sure:
- The paper is below the maximum paper mark (▼▼▼) (1), as overfilling the paper tray will cause paper jams.
  - The side to be printed on is *face down*.
  - The paper guides touch the sides of the paper so it will feed correctly.

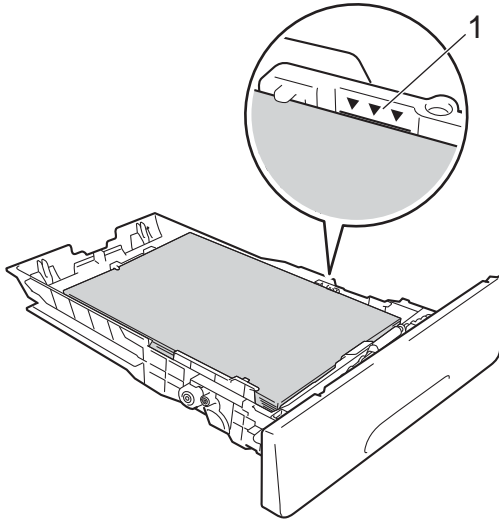

- 5 Put the paper tray *firmly* back in the machine. Make sure the tray is completely inserted into the machine.

- 6 Lift up the support flap (1) to prevent paper from sliding off the face-down output tray, or remove each page as soon as it comes out of the machine.

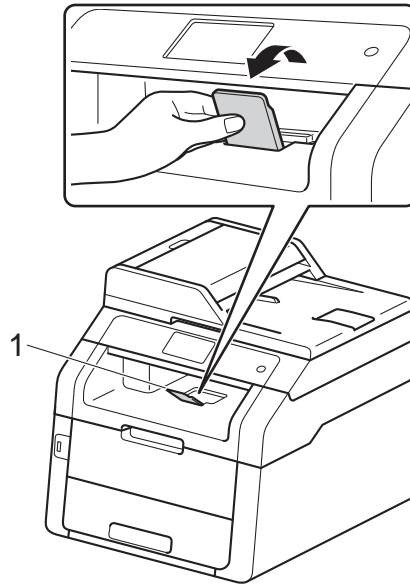



## Loading paper in the manual feed slot

You can load envelopes and special print media one-at-a-time into this slot. Use the manual feed slot to print or copy on labels, envelopes, thicker paper or glossy paper (for the recommended paper to use, see *Acceptable paper and other print media* on page 29).

### NOTE

The machine turns on the Manual Feed mode when you put paper in the manual feed slot.

## Printing on plain paper, thin paper, recycled paper and bond paper from the manual feed slot

- 1 Lift up the support flap (1) to prevent paper from sliding off the face-down output tray, or remove each page as soon as it comes out of the machine.

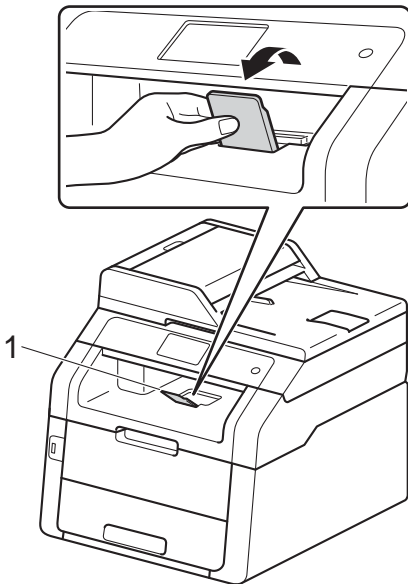

- 2 Open the manual feed slot cover.

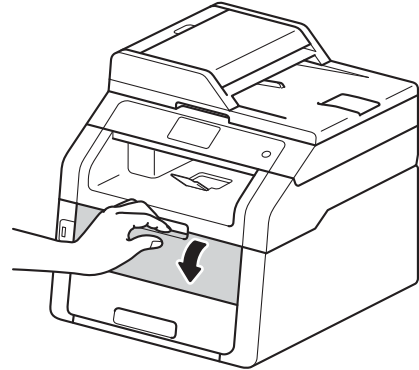

- 3 Use both hands to slide the manual feed slot paper guides to the width of the paper you are going to use.

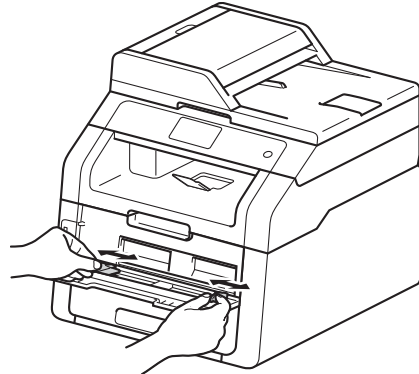

- 4 Use both hands to push one sheet of paper *firmly* into the manual feed slot until the top edge of the paper presses against the paper feed rollers. Continue pressing the paper against the rollers for about two seconds, or until the machine grabs the paper and pulls it in further.

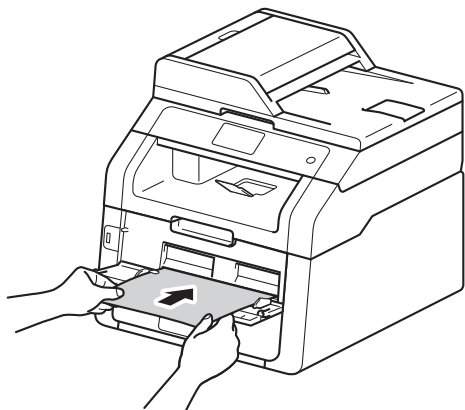

## NOTE

- If the error message `Jam Manual Feed` appears on the Touchscreen, the machine cannot grasp and pull the paper. Reset the machine by removing the paper and then pressing `Start` on the Touchscreen. Reinsert the paper and be sure to press it firmly against the rollers.
- Put the paper into the manual feed slot with the side to be printed on face up.
- Make sure the paper is straight and in the correct position on the manual feed slot. If it is not, the paper may not be fed correctly, resulting in a skewed printout or a paper jam.
- Do not put more than one sheet of paper in the manual feed slot at any one time, as it may cause a jam.

- To easily remove a small printout from the output tray use both hands to lift up the scanner cover as shown in the illustration.

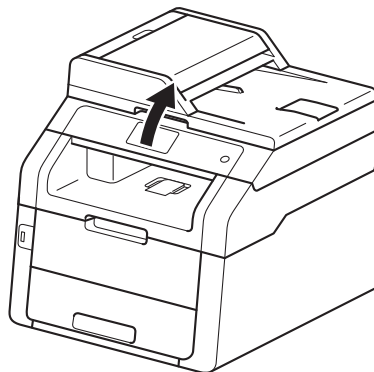

- You can still use the machine while the scanner cover is up. To close the scanner cover, push it down with both hands.

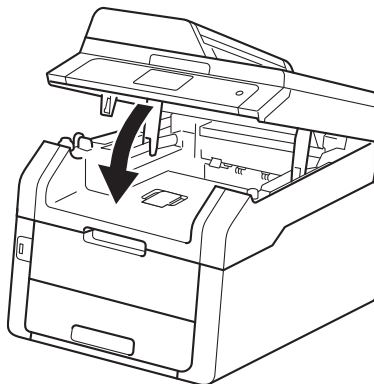

- 5 After the Touchscreen shows `Manual Feed`, return to step 4 to load the next sheet of paper. Repeat for each page you want to print.

### Printing on thick paper, labels, envelopes and glossy paper from the manual feed slot

When the back cover (face-up output tray) is pulled down, the machine has a straight paper path from the manual feed slot through to the back of the machine. Use this paper feed and output method for printing on thick paper, labels, envelopes or glossy paper.

- 1 Open the back cover (face-up output tray).

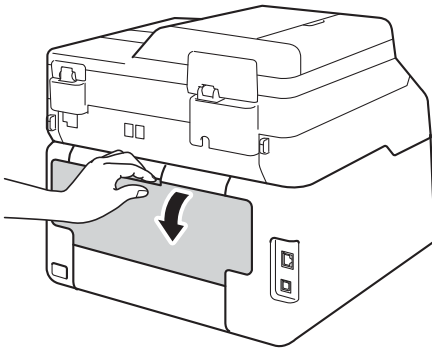

- 2 (For printing envelopes only) Pull down the two grey levers, one on the left side and one on the right side, as shown in the illustration.

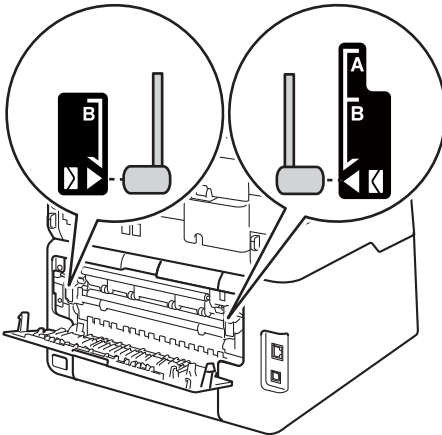

- 3 Open the manual feed slot cover.

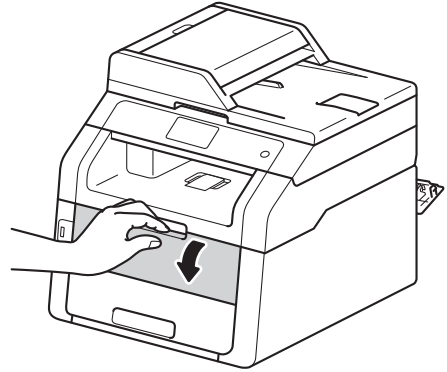

- 4 Use both hands to slide the manual feed slot paper guides to the width of the paper that you are going to use.

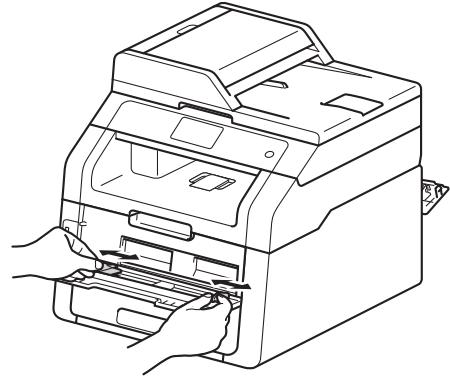

- 5 Use both hands to push one sheet of paper or one envelope *firmly* into the manual feed slot until the top edge of the paper presses against the paper feed rollers. Continue pressing the paper against the rollers for about two seconds, or until the machine grabs the paper and pulls it in further.

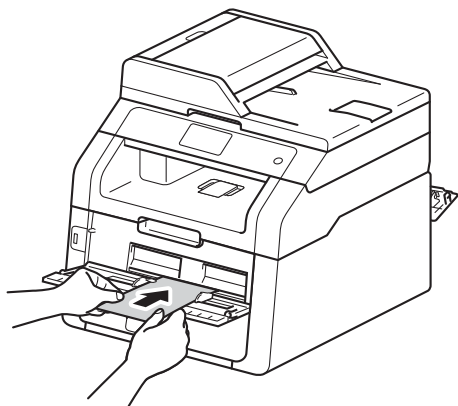
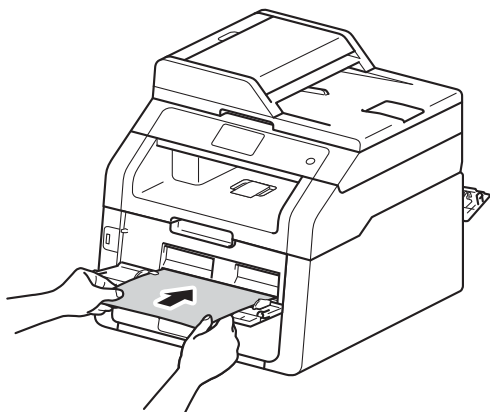

## NOTE

- If the error message `Jam Manual Feed` appears on the Touchscreen, the machine cannot grasp and pull the paper or envelope. Reset the machine by removing the paper and then pressing `Start` on the Touchscreen. Reinsert the paper or envelope and be sure to press it *firmly* against the rollers.
- Put the paper or envelope into the manual feed slot with the side to be printed on face up.

- When **Label** is selected in the printer driver, the machine will feed the paper from the manual feed slot, even if **Manual** is not selected as the paper source.
- Make sure the paper or envelope is straight and in the correct position in the manual feed slot. If it is not, the paper or envelope may not feed correctly, resulting in a skewed printout or a paper jam.
- Pull the paper or envelope out completely when you retry putting the paper into the manual feed slot.
- Do not put more than one sheet of paper or one envelope in the manual feed slot at any one time, as it may cause a jam.

- 6 Send the print data to the machine.

## NOTE

Remove each printed page or envelope immediately to prevent a paper jam.

- 7 After the Touchscreen shows `Manual Feed`, return to step 5 to load the next sheet of paper. Repeat for each page you want to print.
- 8 (For printing envelopes) When you have finished printing, return the two grey levers, that you pulled down at step 2, back to their original positions.
- 9 Close the back cover (face-up output tray) until it locks in the closed position.

## Unscannable and unprintable areas

The figures in the table show maximum unscannable and unprintable areas. These areas may vary depending on the paper size or settings in the application you are using.

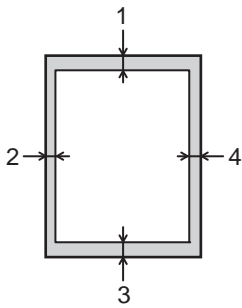

Usage	Document Size	Top (1) Bottom (3)	Left (2) Right (4)
Fax (Sending)	Letter	3 mm	4 mm
	A4	3 mm	(ADF) 1 mm (Scanner Glass) 3 mm
	Legal	3 mm	4 mm
Copy*  * a single copy or a 1 in 1 copy	Letter	4 mm	4 mm
	A4	4 mm	3 mm
	Legal	4 mm	4 mm
Scan	Letter	3 mm	3 mm
	A4	3 mm	3 mm
	Legal (ADF)	3 mm	3 mm
Print	Letter	4.2 mm	4.2 mm
	A4	4.2 mm	4.2 mm
	Legal	4.2 mm	4.2 mm

# Paper settings

## Paper Size

You can use the following sizes of paper for printing faxes: A4, Letter, Legal or Folio.

When you change the size of paper in the tray, you must also change the setting for paper size at the same time so your machine can fit the document or an incoming fax on the page.



You can use the following sizes of paper.

### For printing copies:

A4, Letter, Legal, Executive, A5, A5 L (Long Edge), A6 or Folio (215.9 mm × 330.2 mm)

### For printing faxes:

A4, Letter, Legal or Folio (215.9 mm × 330.2 mm)



- 1 Press .
- 2 (MFC-9340CDW)  
Press Tray Setting.
- 3 Press Paper Size.
- 4 Swipe up or down, or press ▲ or ▼ to display A4, Letter, Legal, EXE, A5, A5 L, A6, Folio, 16K (195x270mm), 16K (184x260mm) or 16K (197x273mm), and press the option you want.
- 5 Press .

## NOTE

- When an appropriate size is not in the tray, received faxes will be stored in the machine's memory and `Size mismatch` will appear on the Touchscreen (for more information, see *Error and maintenance messages* on page 114).
- If the tray is out of paper and received faxes are in the machine's memory, `No Paper` will appear on the Touchscreen. Insert paper in the empty tray.

## Paper Type

To get the best print quality set the machine for the type of paper you are using.

- 1 Press .
- 2 (MFC-9340CDW)  
Press Tray Setting.
- 3 Press Paper Type.
- 4 Swipe up or down, or press ▲ or ▼ to display Thin, Plain Paper, Thick, Thicker, Recycled Paper, and press the option you want.
- 5 Press .

## Acceptable paper and other print media

Print quality may vary according to the type of paper you are using.

You can use the following types of print media: plain paper, thin paper, thick paper, thicker paper, bond paper, recycled paper, labels, envelopes or glossy paper (see *Print media* on page 209).

For best results, follow these instructions:

- DO NOT load different types of paper in the paper tray at the same time because it may cause the paper to jams or misfeed.
- For correct printing, you must choose the same paper size from your software application as the paper in the tray.
- Avoid touching the printed surface of the paper immediately after printing.
- Before you buy a lot of paper, test a small quantity to make sure the paper is appropriate for the machine.
- Use labels that are designed for use in *laser* machines.

## Recommended paper and print media

To get the best print quality, we suggest using the following paper.

Paper Type	Item
Plain paper	APP Blue Flag Ship 70 g/m <sup>2</sup>
	APP Gold Flag Ship 80 g/m <sup>2</sup>
	Advanced Agro Double A 80 g/m <sup>2</sup>

## Type and size of paper

The machine feeds paper from the installed paper tray or the manual feed slot.

**The names for the paper trays in the printer driver and this Guide are as follows:**

Tray and optional unit	Name
Paper Tray	Tray 1
Manual Feed Slot	Manual

## Paper capacity of the paper trays

	Paper size	Paper types	No. of sheets
Paper Tray (Tray 1)	A4, Letter, Legal, B5 (JIS), Executive, A5, A5 L, A6, Folio <sup>1</sup> , 16K(195x270mm), 16K(184x260mm), 16K(197x273mm)	Plain paper, Thin paper, Recycled paper	up to 250 (80 g/m <sup>2</sup> )
Manual Feed Slot	Width: 76.2 to 215.9 mm  Length: 116.0 to 355.6 mm	Plain paper, Thin paper, Thick paper, Thicker paper, Bond paper, Recycled paper, Envelopes, Labels, Glossy paper	1 sheet  1 Envelope

<sup>1</sup> Folio size is 215.9 mm × 330.2 mm.

## Recommended paper specifications

The following paper specifications are appropriate for this machine.

Basis weight	70-90 g/m <sup>2</sup>
Thickness	80-110 μm
Roughness	Higher than 20 sec.
Stiffness	90-150 cm <sup>3</sup> /100
Grain direction	Long grain
Volume resistivity	10e <sup>9</sup> -10e <sup>11</sup> ohm
Surface resistivity	10e <sup>9</sup> -10e <sup>12</sup> ohm-cm
Filler	CaCO <sub>3</sub> (Neutral)
Ash content	Below 23 wt%
Brightness	Higher than 80%
Opacity	Higher than 85%

- Use plain paper that is appropriate for laser/LED machines to make copies.
- Use paper that is 70 to 90 g/m<sup>2</sup>.
- Use long grain paper with a neutral Ph value, and a moisture content of approx. 5%.
- This machine can use recycled paper that meets DIN 19309 specifications.



## Handling and using special paper

The machine is designed to work well with most types of xerographic and bond paper. However, some paper variables may have an effect on print quality or handling reliability. Always test samples of paper before purchasing to ensure desirable performance. Store paper in its original packaging and keep it sealed. Keep the paper flat and away from moisture, direct sunlight and heat.

Some important guidelines when selecting paper are:

- DO NOT use inkjet paper because it may cause a paper jam or damage your machine.
- Preprinted paper must use ink that can withstand the 200 °C temperature of the machine's fusing process.
- If you use bond paper, paper having a rough surface, or paper that is wrinkled or creased, the paper may exhibit degraded performance.

## Types of paper to avoid

### IMPORTANT

Some types of paper may not perform well or may cause damage to your machine.

DO NOT use paper:

- that is highly textured
- that is extremely smooth or shiny
- that is curled or warped

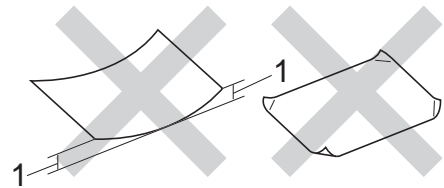

**1 A curl of 2 mm or greater may cause jams to occur.**

- that is coated or has a chemical finish
- that is damaged, creased or folded
- that exceeds the recommended weight specification in this guide
- with tabs and staples
- with letterheads using low temperature dyes or thermography
- that is multipart or carbonless
- that is designed for inkjet printing

The types of paper listed above may damage your machine. This damage is not covered under any Brother warranty or service agreement.

## Envelopes

The machine is designed to work well with most envelopes. However, some envelopes may have feed and print quality problems because of the way they have been made. Envelopes should have edges with straight, well-creased folds. Envelopes should lie flat and not be of baggy or flimsy construction. Use only quality envelopes from a supplier who understands that you will be using the envelopes in a laser machine.

Envelopes can only be fed through the manual feed slot.

We recommend that you print a test envelope to make sure the print results are what you want.

### Types of envelopes to avoid

#### IMPORTANT

DO NOT use envelopes:

- that are damaged, curled, wrinkled or an unusual shape
- that are extremely shiny or textured
- with clasps, staples, snaps or tie strings
- with self-adhesive closures
- that are of a baggy construction
- that are not sharply creased
- that are embossed (raised writing)
- that were previously printed by a laser or LED machine
- that are pre-printed on the inside
- that cannot be arranged neatly when stacked
- that are made of paper that weighs more than the paper weight specifications for the machine
- with edges that are not straight or consistently square
- with windows, holes, cut-outs or perforations

- with glue on the surface as shown in the figure below

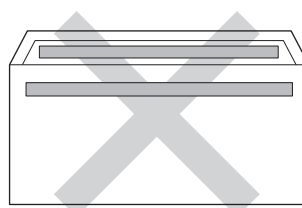

- with double flaps as shown in the figure below

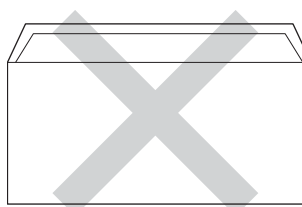

- with sealing flaps that are not folded down when purchased
- with each side folded as shown in the figure below

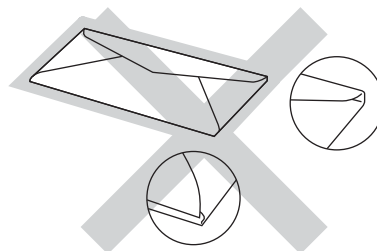

If you use any of the types of envelopes listed above, they may damage your machine. This damage may not be covered under any Brother warranty or service agreement.

Occasionally you may experience paper feed problems caused by the thickness, size and flap shape of the envelopes you are using.

## Labels

The machine will print on most types of labels designed for use with a laser machine. Labels should have an adhesive that is acrylic-based since this material is more stable at the high temperatures in the fuser unit. Adhesives should not come in contact with any part of the machine, because the label stock may stick to the drum unit or rollers and cause jams and print quality problems. No adhesive should be exposed between the labels. Labels should be arranged so that they cover the entire length and width of the sheet. Using labels with spaces may result in labels peeling off and causing serious jams or print problems.

All labels used in this machine must be able to withstand a temperature of 200 °C for a period of 0.1 seconds.

Labels can only be fed through the manual feed slot.

## Types of labels to avoid

Do not use labels that are damaged, curled, wrinkled or an unusual shape.

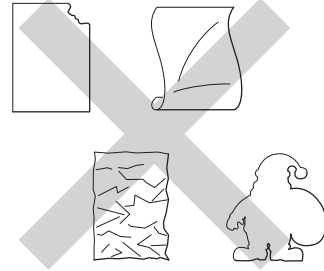

## IMPORTANT

- DO NOT feed part used label sheets. The exposed carrier sheet will damage your machine.
- DO NOT reuse or insert labels that have previously been used or are missing a few labels on the sheet.
- Label sheets should not exceed the paper weight specifications described in this User's Guide. Labels exceeding this specification may not feed or print correctly and may cause damage to your machine.

# 3

## Loading documents

### How to load documents

You can send a fax, make copies, and scan from the ADF (Automatic Document Feeder) and the scanner glass.

### Using the automatic document feeder (ADF)

The ADF can hold up to 35 pages and feeds each sheet individually. We recommend you use standard 80 g/m<sup>2</sup> paper and always fan the pages before putting them in the ADF.

#### Document Sizes Supported

Length:	147.3 to 355.6 mm
Width:	147.3 to 215.9 mm
Weight:	64 to 90 g/m <sup>2</sup>

#### How to load documents

##### IMPORTANT

- DO NOT leave thick documents on the scanner glass. If you do this, the ADF may jam.
- DO NOT use paper that is curled, wrinkled, folded, ripped, stapled, paper-clipped, pasted or taped.
- DO NOT use cardboard, newspaper or fabric with the ADF. Instead use the scanner glass.
- To avoid damaging your machine while using the ADF, DO NOT pull on the document while it is feeding.

##### NOTE

- To scan documents that are not appropriate for the ADF, see *Using the scanner glass* on page 35.
- It is easier to use the ADF if you are loading a multiple page document.
- Make sure documents with correction fluid or written with ink are completely dry.

- 1 Unfold the ADF document support (1). Lift up and unfold the ADF document output support flap (2).

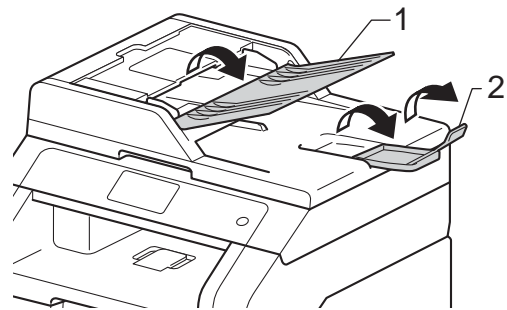

- 2 Fan the pages well.
- 3 Stagger the pages of your document *face up top edge first*, in the ADF until the Touchscreen shows *ADF Ready* and you feel the top page touch the feed rollers.

- 4 Adjust the paper guides (1) to fit the width of your document.

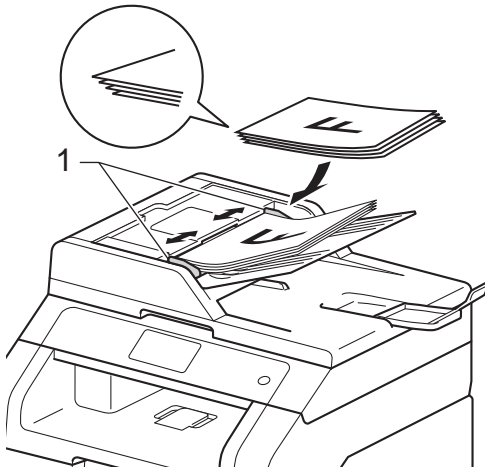

#### NOTE

To scan non-standard documents, see *Using the scanner glass* on page 35.

## Using the scanner glass

You can use the scanner glass to fax, copy or scan pages of a book, one page at a time.

### Document Sizes Supported

Length:	Up to 300.0 mm
Width:	Up to 215.9 mm
Weight:	Up to 2.0 kg

### How to load documents

#### NOTE

To use the scanner glass, the ADF must be empty.

- 1 Lift the document cover.

- 2 Using the document guidelines on the left and top, place the document *face down* in the upper left corner of the scanner glass.

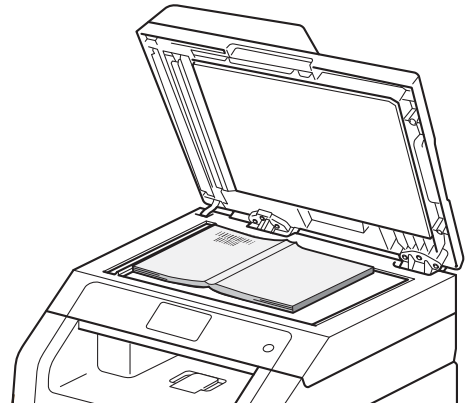
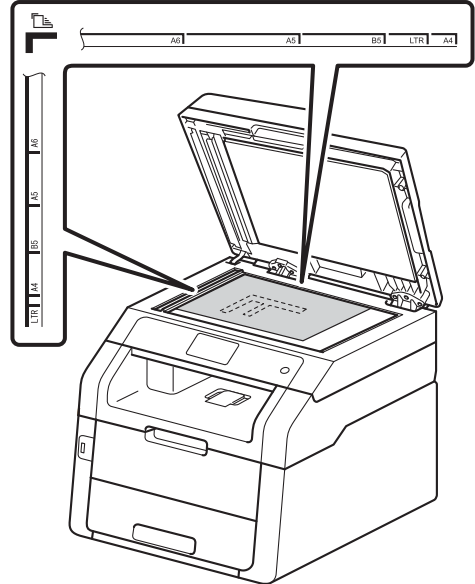

- 3 Close the document cover.

#### IMPORTANT

If the document is a book or is thick do not slam the cover or press on it.

# 4

## Sending a fax

### How to send a fax

The following steps show you how to send a fax. To send multiple pages use the ADF.

- 1 Do one of the following to load your document:
  - Place the document *face up* in the ADF (see *Using the automatic document feeder (ADF)* on page 34).
  - Load your document *face down* on the scanner glass (see *Using the scanner glass* on page 35).

- 2 Do one of the following:
  - When Fax Preview is set to Off, press Fax.
  - When Fax Preview is set to On, press Fax and Sending Faxes.



- The Touchscreen shows:

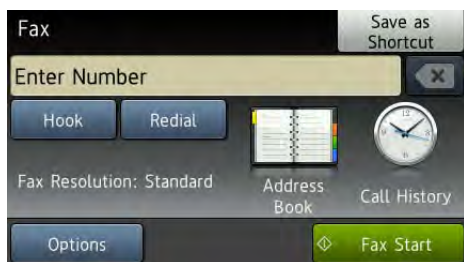

- 3 You can change the following fax sending options. Press Options. Swipe up or down, or press ▲ or ▼ to scroll through the fax options. When the setting you want is displayed, press it and choose your new option. When you have finished changing the options, press OK.

### NOTE

For the following advanced fax sending operations and settings, see *Advanced User's Guide: Sending a fax*

- 2-sided fax (MFC-9340CDW)
- Contrast
- Fax Resolution
- Broadcasting
- Real Time TX
- Overseas Mode
- Delayed Fax
- Batch TX
- Coverpage Note
- Coverpage Setup
- Polled TX

- 4 (MFC-9340CDW) Choose one of the options below:

- To send a 1-sided document, go to step 5.
- To send a 2-sided document, choose the 2-sided scanning format for your 2-sided document as follows:

Press Options.

Swipe up or down, or press ▲ or ▼ to display 2-sided fax and press 2-sided fax.

Press 2-sided Scan: Long Edge or 2-sided Scan: Short Edge.

Press OK.

**NOTE**

You can send 2-sided documents from the ADF.

- 5 Enter the fax number.  
**Using the dial pad**

**Using the Address Book**

- Address Book

**Using call history**

- Call History

(For more information, see *How to dial* on page 53.)

- 6 Press **Fax Start**.

**Faxing from the ADF**

- The machine starts scanning the document.

**Faxing from the scanner glass**

If **Real Time TX** is **On**, the machine will send the document without asking if there are additional pages to scan.

When **Real Time TX** is **Off**:

- If you press **Fax Start**, the machine starts scanning the first page.

When the Touchscreen shows **Next Page?**, do one of the following:



- To send a single page, press **No**. The machine starts sending the document.
- To send more than one page, press **Yes** and place the next page on the scanner glass. Press **OK**. The machine starts scanning the page. (Repeat this step for each additional page.)

**Stop faxing**



To stop faxing, press .

**Faxing Letter size documents from the scanner glass**

When faxing Letter size documents, you must set the scan glass size to **Letter**; otherwise, a portion of your faxes will be missing.

- 1 Do one of the following:
  - When **Fax Preview** is set to **Off**, press  (**Fax**).
  - When **Fax Preview** is set to **On**, press  (**Fax**) and **Sending Faxes**.
- 2 Press **Options**.
- 3 Swipe up or down, or press **▲** or **▼** to display **Glass Scan Size**.
- 4 Press **Glass Scan Size**.
- 5 Press **Letter**.
- 6 Press **OK**.

**Cancelling a fax in process**

Press  to cancel the fax. If you press  while the machine is dialling or sending, the Touchscreen will show **Cancel Job?**.



Press **Yes** to cancel the fax.

## Transmission Verification Report

You can use the Transmission Verification Report as proof that you sent a fax. This report lists the receiving party's name or fax number, the time and date of transmission, duration of transmission, number of pages sent, and whether or not the transmission was successful.

There are several settings available for the Transmission Verification Report:

- **On:** Prints a report after every fax you send.
- **On+Image:** Prints a report after every fax you send. A portion of the fax's first page appears on the report.
- **Off:** Prints a report if your fax is unsuccessful due to a transmission error. **Off** is the factory setting.
- **Off+Image:** Prints a report if your fax is unsuccessful due to a transmission error. A portion of the fax's first page appears on the report.

- 1 Press .
- 2 Press **All Settings**.
- 3 Swipe up or down, or press ▲ or ▼ to display **Fax**.
- 4 Press **Fax**.
- 5 Swipe up or down, or press ▲ or ▼ to display **Report Setting**.
- 6 Press **Report Setting**.
- 7 Press **Transmission**.
- 8 Press **On**, **On+Image**, **Off** or **Off+Image**.
- 9 Press .

## NOTE

- If you choose **On+Image** or **Off+Image**, the image will not appear on the Transmission Verification Report if **Real Time Transmission** is set to **On**. (see *Advanced User's Guide, Real Time Transmission*).
- If the transmission is successful, **OK** will appear next to **RESULT** on the Transmission Verification Report. If the transmission is not successful, **ERROR** will appear next to **RESULT**.





## Receive modes

By default, your machine will automatically receive any faxes that are sent to it. There are four receive modes of this machine as below. (For more detailed information about the receive modes, see *Using receive modes* on page 40.)

Touchscreen Display	Factory Default Ring Delay
Fax Auto	Ring Delay: 2 times Fax detection: On
Fax/Tel	Ring Delay: 2 times F/T Ring Time: 20 seconds
Manual	
External TAD	

To set the receive mode follow the instructions below.

- 1 Press .
- 2 Press All Settings.
- 3 Swipe up or down, or press ▲ or ▼ to display Fax.
- 4 Press Fax.
- 5 Swipe up or down, or press ▲ or ▼ to display Setup Receive.
- 6 Press Setup Receive.
- 7 Swipe up or down, or press ▲ or ▼ to display Receive Mode.
- 8 Press Receive Mode.
- 9 Press Fax Auto, Fax/Tel, External TAD or Manual.
- 10 Press .

To see the current receive mode, press  on the Touchscreen.

## Using receive modes

Mode	Function	Help
Fax Auto	Each call recognized as fax and send fax signal. However, you can answer the call within the number of rings.	<p>Factory setting of Ring Delay is 2 (0-10 times available, please see <i>Ring Delay</i> on page 41). After ringing 2 times, the fax machine send fax-receiving signals automatically;</p> <p>Tip: If your machine is connecting an external answering phone device, and often use it to answer incoming calls, you could set the ring time through 4 to 6 times.</p> <p>Within the recommended ringing times, you can use the external answering phone device to answer and talk.<sup>1</sup></p>
Fax/Tel	<p>Automatically determine whether the incoming call is telephone or fax calls.</p> <p>Non-Fax call will make a fast double-ring to inform you answer the phone.</p>	<p>Factory setting of Ring Delay is 2 (0-10 times available, see <i>Ring Delay</i> on page 41). F/T ring time (a fast double-ring) is 20 seconds.</p> <p>According to incoming call after the fax machine rings 2 times:</p> <ol style="list-style-type: none"> <li>1) For the fax call, send fax received signal;</li> <li>2) For the telephone call, make a fast double-ring, waiting for you answer the phone.</li> </ol> <p>Tip: If your machine is connecting an external answering phone device, you could set the ringing time through 4 to 6 times to answer the call.<sup>1</sup></p>
Manual	Machine doesn't recognize each call, only as a common phone call that you need to determine after answering the phone.	<p>Answering the call, or if the caller wants to send you a fax, press <b>Fax Start</b> button (under easy mode) to receive faxes.</p> <p>Tip: If your machine is connecting an external answering phone device, you can use the external answering phone device to answer and talk.<sup>1</sup></p>
External TAD	The external answering machine (TAD) automatically answers every call. Voice messages are stored on the external TAD. Fax messages are printed.	<p>Use this mode if you have connected an external answering machine to your machine. The TAD setting works only with an external answering machine.</p> <p>Note: Ring Delay and F/T Ring Time do not work in this setting.</p>



<sup>1</sup> If the caller wants to send a fax during a call or the caller sends you a fax call, please press **Fax Start** button (under easy mode) on the Touchscreen of the machine or press \*51 keys on the external answering phone device (You have to turn on the remote codes, see *Using Remote Codes* on page 51 to give fax receiving signals).

## Receive Mode settings

### Ring Delay

The Ring Delay setting sets the number of times the machine rings before it answers in Fax Auto and Fax/Tel modes.

If you have external or extension telephones on the same line as the machine, choose the maximum number of rings (see *Fax Detect* on page 42 and *Operation from external or extension telephones* on page 50).

- 1 Press .
- 2 Press All Settings.
- 3 Swipe up or down, or press ▲ or ▼ to display Fax.
- 4 Press Fax.
- 5 Swipe up or down, or press ▲ or ▼ to display Setup Receive.
- 6 Press Setup Receive.
- 7 Swipe up or down, or press ▲ or ▼ to display Ring Delay.
- 8 Press Ring Delay.
- 9 Press to choose how many times the line rings before the machine answers.
- 10 Press .

### F/T Ring Time (Fax/Tel mode only)

When somebody calls your machine, you and your caller will hear the normal telephone ring sound. The number of rings is set by the Ring Delay setting.

If the call is a fax, then your machine will receive it; however, if it is a voice call the machine will sound the F/T ring (pseudo/double-ring) for 20 seconds. If you hear the F/T ring it means that a voice caller is on the line.

Because the F/T ring is made by the machine, extension and external telephones will *not* ring; however, you can still answer the call on any telephone (for more information, see *Using Remote Codes* on page 51).

#### NOTE

Even if the caller hangs up during the pseudo/double-ringing, the machine will continue to ring for 20 seconds.

## Fax Detect

---

### If Fax Detect is On:

The machine can receive a fax automatically, even if you answer the call. When you see *Receiving* on the Touchscreen or hear a click on the phone line through the handset you are using, just replace the handset. Your machine will do the rest.

### If Fax Detect is Off:



If you are at the machine and answer a fax call first by lifting the external handset, then press *Fax Start* to receive the Fax. (If you set *Fax Mode* to *Advanced Mode*, Press *Fax Start*, and then press *Receive*.)

If you answered at an extension telephone press \*51 (see *Operation from external or extension telephones* on page 50).

### NOTE

---

- If this feature is set to *On*, but your machine does not connect a fax call when you lift an extension telephone handset, press the fax receive code \*51.
  - If you send faxes from a computer on the same telephone line and the machine intercepts them, set *Fax Detect* to *Off*.
- 

- 1 Press .
- 2 Press *All Settings*.
- 3 Swipe up or down, or press ▲ or ▼ to display *Fax*.
- 4 Press *Fax*.
- 5 Swipe up or down, or press ▲ or ▼ to display *Setup Receive*.
- 6 Press *Setup Receive*.
- 7 Swipe up or down, or press ▲ or ▼ to display *Fax Detect*.
- 8 Press *Fax Detect*.
- 9 Press *On* (or *Off*).
- 10 Press .

# Fax Preview (Black and White only)



## How to preview a received fax

You can view received faxes on the

Touchscreen by pressing  (Fax) and

then  (Received Faxes). When the machine is in Ready mode, a pop-up message will appear on the Touchscreen to alert you of new faxes.

## Setting Fax Preview

- 1 Press .
- 2 Press  (Fax Preview).
- 3 Press On (or Off).
- 4 Press Yes.
- 5 The Touchscreen will tell you that any future faxes will not be printed as you receive them.  
Press Yes.
- 6 Press .

## NOTE

When Fax Preview is turned on, a backup copy of received faxes will not be printed for Fax Forwarding and PC-Fax Receiving operations, even if you set Backup Print to On.

## Using Fax Preview

When you receive a fax, you will see a pop-up message on the Touchscreen. (For example: New Fax(es):01 [View])

- 1 Press View.  
The Touchscreen will display the fax list.

## NOTE









- Although printed faxes show the received date and time when Fax Receive Stamp is turned on, the Fax Preview screen will not show the received date and time.
- The fax list includes the old faxes and the new fax. The new fax is indicated by a blue mark next to the fax.
- To see a fax that has already been previewed, press Fax and Received Faxes.

- 2 Swipe up or down, or press ▲ or ▼ to display the fax number of the fax you want.
- 3 Press the fax you want.

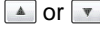
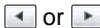
## NOTE



- If your fax is large there may be a delay before it is displayed.
- The Touchscreen will show the current page number and total pages of the fax message. When your fax message is over 99 pages the total number of pages will be shown as "XX."

Press the Touchscreen or Touchpanel to perform the following operations.



	Description
	Enlarge the fax.
	Reduce the fax.
	Scroll vertically.
	Scroll horizontally.
	Rotate the fax clockwise.
	Delete the fax. Press <b>Yes</b> to confirm.
	Go back to the previous page.
	Go to the next page.
	Go back to the fax list.
Start	Print the fax.

- 4 Press .



### How to print a fax

- 1 Press  (Fax).
- 2 Press **Received Faxes**.
- 3 Press the fax you want.
- 4 Press **Start**.
- 5 Press .

### How to print all faxes in the list



- 1 Press  (Fax).
- 2 Press **Received Faxes**.
- 3 Press **Print/Delete**.
- 4 Do one of the following:
  - Press **Print All (New Faxes)** to print all faxes you have not yet viewed.
  - Press **Print All (Old Faxes)** to print all faxes you have viewed.
- 5 Press .

### How to delete all faxes in the list

- 1 Press  (Fax).
- 2 Press **Received Faxes**.
- 3 Press **Print/Delete**.
- 4 Do one of the following:
  - Press **Delete All (New Faxes)** to delete all faxes you have not yet viewed.
  - Press **Delete All (Old Faxes)** to delete all faxes you have viewed.
- 5 Press **Yes** to confirm.
- 6 Press .

## Turning off Fax Preview

---

- 1 Press .
- 2 Press  (Fax Preview).
- 3 Press Off.
- 4 Press Yes to confirm.
- 5 If there are faxes stored in the memory, do one of the following:
  - If you do not want to print the stored faxes, press Continue.  
Press Yes to confirm. Your faxes will be deleted.
  - To print all the stored faxes, press Print All Faxes Before Delete.
  - If you do not want to turn off Fax Preview, press Cancel.
- 6 Press .

## How to use PC-FAX

### PC-Fax Receive (For Windows® only)

If you turn on the PC-Fax Receive feature your MFC will store received faxes in memory and send them to your computer automatically. You can then use your computer to view and store these faxes.

Even if you turn off your computer (at night or on the weekend, for example), your MFC will receive and store your faxes in its memory. The number of received faxes that are stored in the memory will appear on the Touchscreen.

When you start your computer and the PC-Fax Receiving software runs, your MFC transfers your faxes to your computer automatically.

To transfer the received faxes you must have the PC-FAX Receiving software running on your PC.

Follow the instructions for the operating system you are using.

- (Windows® XP, Windows Vista® and Windows® 7)

From the  (Start) menu, select **All Programs > Brother > MFC-XXXX > PC-FAX Receiving > Receive**. (XXXX is your model name.)

- (Windows® 8)

Click  (Brother Utilities), and then click the drop-down list and select your model name (if not already selected). Click **PC-FAX Receive** in the left navigation bar, and then click **Receive**.

On your machine, complete the following steps:

- 1 Press .
- 2 Press All Settings.
- 3 Swipe up or down, or press ▲ or ▼ to display Fax.
- 4 Press Fax.
- 5 Swipe up or down, or press ▲ or ▼ to display Setup Receive.
- 6 Press Setup Receive.
- 7 Swipe up or down, or press ▲ or ▼ to display Memory Receive.
- 8 Press Memory Receive.
- 9 Press PC Fax Receive.
- 10 The Touchscreen shows a reminder to start the PC-FAX Receiving program on your computer. If you have started the PC-FAX Receiving program, press OK. For more information about how to start the PC-FAX Receiving program, see Software User's Guide.
- 11 Swipe up or down, or press ▲ or ▼ to display <USB> or your computer name if the machine is connected to a network. Press <USB> or your computer name. Press OK.
- 12 Press Backup Print: On Or Backup Print: Off.

### IMPORTANT

If you choose Backup Print: On, the machine will also print the fax at your machine so you will have a copy.

- 13 Press .



**NOTE**

- Before you can set up PC-Fax Receive you must install the MFL-Pro Suite software on your computer. Make sure your computer is connected and turned on (see Software User's Guide).
- If your machine has an error and is unable to print faxes from memory, you can use this setting to transfer your faxes to a computer (see *Transferring your faxes or Fax Journal report* on page 122).
- PC-Fax Receive is not supported in Mac OS.

**PC-FAX Send**

The Brother PC-FAX feature lets you use your computer to send a document from an application as a standard fax. You can send a file created in any application on your computer as a PC-FAX. You can even attach a cover page (for more information, see Software User's Guide).

**How to send a PC-FAX:**

Contact your application vendor if you need more support.

- 1 From your application select **File**, and then **Print**.  
The Print dialog box will be displayed. (The steps may vary depending on your application.)
- 2 Select the **Brother PC-FAX v.3**.
- 3 Click **OK**.  
The **Brother PC-FAX** user interface will be displayed.
- 4 Enter the recipient's fax number using your computer keyboard or by clicking the numeric keypad of the **Brother PC-FAX** user interface. You can also select a stored number from the **Address Book**.
- 5 Click  when using your computer keyboard or the numeric keypad.
- 6 Click **Start**.  
Your document will be sent to the Brother machine and then faxed to the recipient.

# 7

## Telephone and external devices

### Connecting an external TAD

You can connect an external Telephone Answering Device (TAD) to the same line as your machine. When the TAD answers a call, your machine will “listen” for the CNG (fax calling) tones sent by a sending fax machine. If it hears them it will take over the call and receive the fax. If it does not hear them, it will let your TAD take a voice message and the display will show *Telephone*.

The external TAD must answer within four rings (we recommend you set it to two rings). This is because your machine cannot hear the CNG tones until the external TAD has picked up the call. The sending machine will send CNG tones for only eight to ten seconds longer. We do not recommend using the toll saver feature on your external TAD if it needs more than four rings to activate it.

#### NOTE

If you have problems receiving faxes, reduce the Ring Delay setting on your external TAD to one or two rings.

### Connections

The external TAD must be connected as shown in the illustration below.

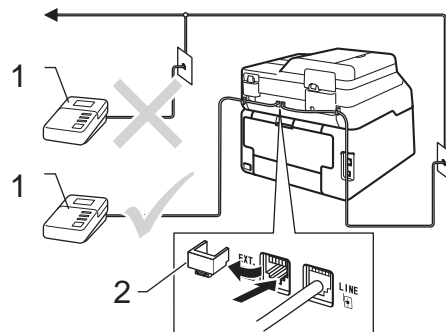

#### 1 TAD

#### 2 Protective Cap

- 1 Set your external TAD to one or two rings. (The machine's Ring Delay setting does not apply.)
- 2 Record the outgoing message on your external TAD.
- 3 Set the TAD to answer calls.
- 4 Set the Receive Mode on your machine to *External TAD* (see *Using receive modes* on page 40).

## Recording an outgoing message (OGM)

---

- 1 Record 5 seconds of silence at the beginning of your message. This allows your machine time to listen for fax tones.
- 2 Limit your speaking to 20 seconds.
- 3 End your 20-second message by giving your Remote Activation code for people sending manual faxes. For example: "After the beep, leave a message or press \*51 and Start to send a fax."

### NOTE

---

- You must turn the Remote Codes setting to **On** to use the Remote Activation code \*51 (see *Using Remote Codes* on page 51).
  - We recommend beginning your OGM with an initial 5 second silence because the machine may not hear the fax tones over a voice. You may try leaving out this pause, but if your machine has trouble receiving faxes, then you should re-record the OGM to include it.
- 

## Multi-line connections (PABX)

---

Most offices use a central telephone system. Brother recommends that all our Fax/MFC machines be connected to a discreet (dedicated) line. Although a particular PABX may appear to work with a particular model of fax machine, we cannot guarantee that the unit will operate correctly.

While it is often relatively simple to connect a fax machine to a PABX (Private Automatic Branch Exchange), we suggest that you contact the company that installed your telephone system and ask them to connect the fax machine for you.

Brother does not recommend the use of a PABX line. PABX limitations in general can cause some functions of the fax machine not to work correctly.

## External and extension telephones

### NOTE

You must turn the Remote Codes setting to on to use the Remote Activation Code \*51 and Remote Deactivation Code #51 (see *Using Remote Codes* on page 51).

## Connecting an external or extension telephone

You can connect a separate telephone directly to your machine as shown in the diagram below.

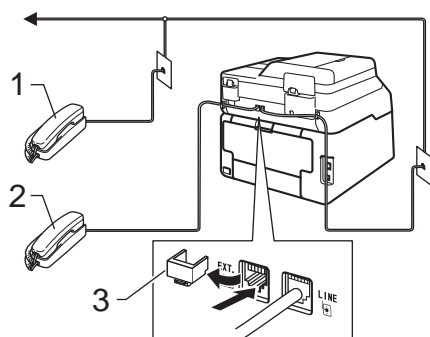

- 1 Extension telephone
- 2 External telephone
- 3 Protective Cap

## Operation from external or extension telephones

If you answer a fax call on an extension telephone, or an external telephone that is correctly connected to the machine into the correct socket on the machine, you can make your machine take the call by using the Remote Activation code. When you press the Remote Activation code \*51 the machine starts to receive the fax.

If you answer a call and no one is on the line:

You should assume that you're receiving a manual fax.

Press \*51 and wait for the chirp or until the Touchscreen shows *Receiving*, and then hang up.

### NOTE

You can also use the Fax Detect feature to make your machine automatically take the call (see *Fax Detect* on page 42).

## For Fax/Tel mode only

When the machine is in Fax/Tel mode, it will use the F/T Ring Time (fast double-ringing) to alert you to pick up a voice call.

Lift the external telephone's handset, and then press *Pickup* to answer.

If you are at an extension telephone, you will need to lift the handset during the F/T Ring Time and then press #51 between the fast double-rings. If no one is on the line, or if someone wants to send you a fax, send the call back to the machine by pressing \*51.

## Using a non-Brother cordless external handset

---

If your non-Brother cordless telephone is connected to the telephone line cord (see page 50) and you typically carry the cordless handset elsewhere, it is easier to answer calls during the Ring Delay.

If you let the machine answer first, you will have to go to the machine so you can press **Pickup** to transfer the call to the cordless handset.

### NOTE

---

- If you are always disconnected when accessing your external TAD remotely, try changing the Remote Activation Code and Remote Deactivation Code to another three-digit code using the numbers 0-9, \*, #.
  - Remote Codes might not work with some telephone systems.
  - Not all brands of cordless telephones are compatible for use with your machine.
- 

## Using Remote Codes

---

### Remote Activation Code

If you answer a fax call on an external or extension telephone, you can tell your machine to receive it by pressing the Remote Activation Code **\*51**. Wait for the chirping sounds then replace the handset (see *Fax Detect* on page 42). Your caller will have to press **Start** to send the fax.

If you answer a fax call at the external telephone, you can make the machine receive the fax by pressing **Fax Start** and then pressing **Receive**.



### Remote Deactivation Code

If you receive a voice call and the machine is in F/T mode, it will start to sound the F/T ring (fast double-ring) after the initial ring delay. If you pick up the call on an extension telephone you can turn the F/T ring off by pressing **#51** (make sure you press this *between* the rings).

If the machine answers a voice call and fast double-rings for you to take over, you can take the call at the external telephone by pressing **Pickup**.



## Turning on the Remote Codes

You must turn the Remote Codes setting to **On** to use the Remote Activation Code and Remote Deactivation Code.

- 1 Press .
- 2 Press **All Settings**.
- 3 Swipe up or down, or press ▲ or ▼ to display **Fax**.
- 4 Press **Fax**.
- 5 Swipe up or down, or press ▲ or ▼ to display **Setup Receive**.
- 6 Press **Setup Receive**.
- 7 Swipe up or down, or press ▲ or ▼ to display **Remote Codes**.
- 8 Press **Remote Codes**.
- 9 Press **Remote Codes**.
- 10 Press **On**.
- 11 If you do not want to change the Remote Activation Code, press  on the Touchscreen.
- 12 Press .

## Changing the Remote Codes



The preset Remote Activation Code is \***51**. The preset Remote Deactivation Code is #**51**. If you are always disconnected when accessing your External TAD, try changing the three-digit remote codes, for example **###** and 555.

- 1 Press .
- 2 Press **All Settings**.
- 3 Swipe up or down, or press ▲ or ▼ to display **Fax**.
- 4 Press **Fax**.
- 5 Swipe up or down, or press ▲ or ▼ to display **Setup Receive**.
- 6 Press **Setup Receive**.
- 7 Swipe up or down, or press ▲ or ▼ to display **Remote Codes**.
- 8 Press **Remote Codes**.
- 9 Do one of the following:
  - If you want to change the Remote Activation Code, press **Act . Code**. Enter the new code, and then press **OK**.
  - If you want to change the Remote Deactivation Code, press **Deact . Code**. Enter the new code, and then press **OK**.
  - If you do not want to change the Codes, go to step 10.
  - If you want to turn the Remote Codes **On** or **Off**, press **Remote Codes**. Press **On** or **Off**.
- 10 Press .

## How to dial

You can dial in any of the following ways.

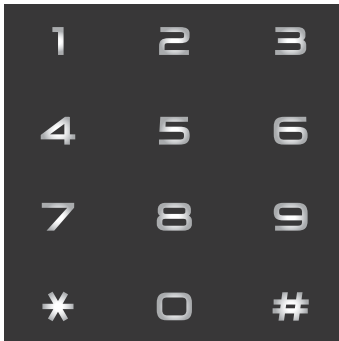

### Manual dialling

- 1 Load your document.
- 2 Do one of the following:
  - When Fax Preview is set to Off, press  (Fax).
  - When Fax Preview is set to On, press  (Fax) and Sending Faxes.
- 3 Press all digits of the fax number.



- 4 Press Fax Start.

### Dialling from the Address Book

- 1 Load your document.
- 2 Press  (Fax).
- 3 Press Address Book.
- 4 Do one of the following:
  - Swipe up or down, or press ▲ or ▼ to display the number you want.
  - Press , and then enter the first letter of the name and press OK.
- 5 Press the number or the name you want.
- 6 To send a fax, press Apply.
- 7 Press Fax Start.  
The machine scans and sends the fax.

### Fax redial

If you are sending a fax automatically and the line is busy, the machine will automatically redial up to three times at five minute intervals.

Redial only works if you dialled from the machine.

## Tone or Pulse

If you have a Pulse dialing service, but need to send Tone signals (for example, for telephone banking), follow the instructions below. If you have Touch Tone service, you will not need this feature to send tone signals.

- 1 Press **Hook**.
- 2 Press **#** on the machine's control panel. Any digits dialed after this will send tone signals.  
When you have finished with the call, the machine will return to the Pulse dialing service.

## Storing numbers

You can set up your machine to do the following types of easy dialling: Address Book and Groups for broadcasting faxes. When you dial an Address Book number, the Touchscreen shows the number.

### NOTE

If you lose electrical power, the Address Book numbers that are in the memory will not be lost.

## Storing a pause

Press **Pause** to insert a 3.5-second pause between numbers. You can press **Pause** as many times as needed to increase the length of the pause.

## Storing Address Book numbers

You can store up to 200 Addresses with a name.

- 1 Press  (Fax).
- 2 Press **Address Book**.
- 3 Press **Edit**.
- 4 Press **Add New Address**.
- 5 Press **Name**.
- 6 Enter the name using the keyboard on the Touchscreen (up to 20 characters). (To help you enter letters, see *Entering text* on page 204.)  
Press **OK**.
- 7 Press **pinyin**.



- 8 Enter the pinyin using the keyboard on the Touchscreen (up to 20 characters). (To help you enter letters, see *Entering text* on page 204.)  
Press **OK**.
- 9 Press **Address**.
- 10 Enter the fax or telephone number using the keyboard on the Touchscreen (up to 20 digits).  
Press **OK**.

## NOTE

*If you downloaded Internet Fax:*

If you want to store an E-mail address to use with Internet Fax or Scan to E-mail server, press  and enter the E-mail address (see *Entering text* on page 204), and press **OK**.

- 11 Press **OK**.
- 12 Do one of the following:
  - To store another Address Book number, repeat steps 3 - 12.
  - To finish storing numbers, press .

## Changing Address Book names or numbers

You can change or delete an Address Book name or number that has already been stored.

If the stored number has a scheduled job, such as a delayed fax or a fax forwarding number, it will be dimmed on the Touchscreen. You cannot select the number to make changes or to delete it unless you first cancel the scheduled job (see *Advanced User's Guide, Checking and cancelling waiting jobs*).

- 1 Press  (Fax).
- 2 Press **Address Book**.
- 3 Press **Edit**.
- 4 Do one of the following:
  - Press **Change** to edit the names or numbers. Go to step 5.
  - Press **Delete** to display **Delete**. Delete numbers by pressing them to display a red check mark.  
  
Press **OK**.  
  
Press **Yes** to confirm. Go to step 9.
- 5 Swipe up or down, or press **▲** or **▼** to display the number you want.
- 6 Press the number you want.
- 7 Do the following:
  - To change the name, press **Name**. Enter the new name (up to 20 characters) using the keyboard on the Touchscreen. (To help you enter letters, see *Entering text* on page 204).  
  
Press **OK**.

- To change the pinyin, press `pinyin`. Enter the new pinyin (up to 20 characters) using the keyboard on the Touchscreen. (To help you enter letters, see *Entering text* on page 204).
- To change the fax or telephone number, press `Address`. Enter the new fax or telephone number (up to 20 digits) using the keyboard on the Touchscreen.

Press `OK`.

## NOTE

---

*How to change the stored name or number:*

To change a character, press `◀` or `▶` to position the cursor to highlight the incorrect character, and then press . Enter the new character or number.

---

- 8 Press `OK` to finish.

To change another Address Book number, repeat steps 3 - 8.

- 9 Press .

## How to copy

The following steps show the basic copy operation.

- 1 Do one of the following to load your document:
  - Place the document *face up* in the ADF (see *Using the automatic document feeder (ADF)* on page 34).
  - Load your document *face down* on the scanner glass (see *Using the scanner glass* on page 35).
- 2 Press the **Copy** button on the Touchscreen.



- The Touchscreen shows

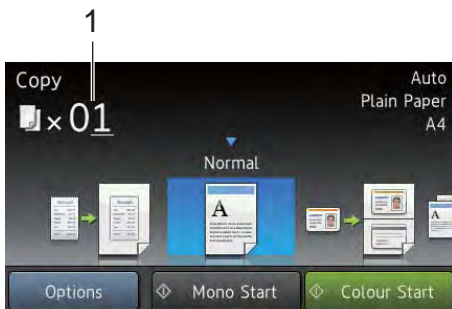

### 1 No. of Copies

You can enter the number of copies by using the dial pad.

- 3 For multiple copies, enter the two-digit number (up to 99).
- 4 Press **Colour Start** or **Mono Start**.

## Stop copying

To stop copying, press .

## Copy preset settings

You can copy with a variety of settings that are already set up for you in the machine simply by pressing them.

The following preset settings are available.

- Receipt
- Normal
- 2in1 (ID)
- 2in1
- 2-sided (1⇒2)
- 2-sided (2⇒2) (MFC-9340CDW)
- Paper Save

- 1 Load your document.
- 2 Press  (Copy).
- 3 Swipe left or right to display **Receipt**, **Normal**, **2in1 (ID)**, **2in1**, **2-sided (1⇒2)**, **2-sided (2⇒2)** or **Paper Save**.
- 4 Enter the number of copies you want.
- 5 Do one of the following:
  - To change more settings, go to step 6.
  - If you have finished changing settings, go to step 9.
- 6 Press **Options**.
- 7 Swipe up or down, or press **▲** or **▼** to display the available settings, and then press the setting you want.

- 8 Swipe up or down, or press ▲ or ▼ to display the available options, and then press your new option. Repeat steps 7 and 8 for each setting you want. If you have finished changing the settings, press OK.

## NOTE

Save the settings as a Shortcut by pressing *Save as Shortcut*.

- 9 Press *Colour Start* or *Mono Start*.

## Copy Options

You can change the following copy settings. Press *Copy* and then press *Options*. Swipe up or down, or press ▲ or ▼ to scroll through the copy settings. When the setting you want is displayed, press it and choose your option. When you have finished changing the options, press OK.

### (Advanced User's Guide)

For more information about changing the following settings, see *Advanced User's Guide: Copy settings*:

- *Quality*
- *Enlarge/Reduce*
- *Density*
- *Contrast*
- *Stack/Sort*
- *Page Layout*
- *2in1 (ID)*
- *Colour Adjust*
- *2-sided Copy*
- *2-sided Copy Page Layout (MFC-9340CDW)*
- *Remove Background Colour*
- *Save as Shortcut*

# 10

## Printing data from a USB Flash memory drive or digital camera supporting mass storage (For MFC-9340CDW)

With the Direct Print feature, you do not need a computer to print data. You can print by just plugging your USB Flash memory drive into the machine's USB direct interface. You can also connect and print directly from a camera set to USB mass storage mode.

You can use a USB Flash Memory Drive that has the following specifications:

USB Class	USB Mass Storage Class
USB Mass Storage Sub Class	SCSI or SFF-8070i
Transfer protocol	Bulk transfer Only
Format <sup>1</sup>	FAT12/FAT16/FAT32
Sector size	Max. 4096 Byte
Encryption	Encrypted devices are not supported.

<sup>1</sup> NTFS format is not supported.

### NOTE

- Some USB Flash memory drives may not work with the machine.
- If your camera is in PictBridge mode, you cannot print data. See the documentation supplied with your camera to switch from PictBridge mode to mass storage mode.

## Creating a PRN file for direct printing

### NOTE

The screens in this section may vary depending on your application and operating system.

- 1 From the menu bar of an application, click **File**, then **Print**.
- 2 Choose **Brother MFC-XXXX Printer** (1) and check the **Print to file** box (2). Click **Print**.

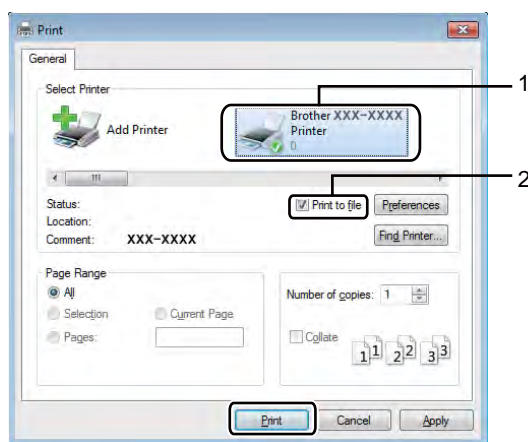

- 3 Choose the folder you want to save the file to and enter the file name if prompted.

If you are prompted for a file name only, you can also specify the folder you want to save the file in by entering the directory name. For example:  
C:\Temp\FileName.prn

If a USB Flash memory drive is connected to your computer, you can save the file directly to the USB Flash memory drive.

## Printing data directly from the USB Flash memory drive or digital camera supporting mass storage

### NOTE

- Make sure your digital camera is turned on.
- Your digital camera must be switched from PictBridge mode to mass storage mode.

- 1 Connect your USB Flash memory drive or digital camera to the USB direct interface (1) on the front of the machine. The Touchscreen will automatically show the USB memory menu to confirm the intended use of the USB devices.

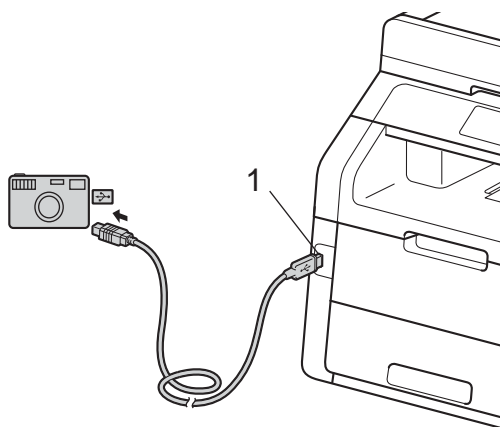
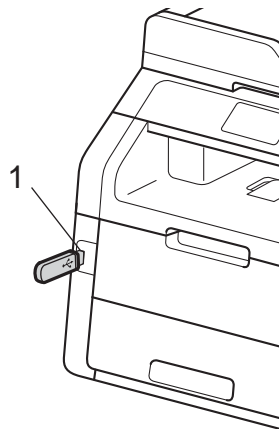

### NOTE

- If an error occurs, the USB memory menu will not appear on the Touchscreen.
- When the machine is in Deep Sleep mode, the Touchscreen does not show any information even if you connect a USB flash memory drive to the USB direct interface. Press the Touchscreen to wake up the machine.

- 2 Press **Direct Print**.

#### NOTE

If your machine has been set to **Secure Function Lock On**, you may not be able to access **Direct Print** (see *Advanced User's Guide: Switching Users*).

- 3 Swipe up or down, or press **▲** or **▼** to choose the folder name and file name you want.  
If you have selected the folder name, swipe up or down, or press **▲** or **▼** to choose the file name you want.

#### NOTE

If you want to print an index of the files, press **Index Print** on the Touchscreen. Press **Colour Start** or **Mono Start** to print the data.

- 4 Do one of the following:
  - Press **Print Settings**. Go to step 5.
  - If you do not want to change the current settings, go to step 8.

- 5 Swipe up or down, or press **▲** or **▼** to display the setting you want.

- 6 Press the option you want.

#### NOTE

- You can choose the following settings:
  - Paper Type
  - Paper Size
  - Multiple Page
  - Orientation
  - 2-sided
  - Collate
  - Print Quality
  - PDF Option
- Depending on the file type, some of these settings may not appear.

- 7 Do one of the following:
  - To change another setting, repeat step 5.
  - If you do not want to change other settings, press **OK** and go to step 8.

- 8 Enter the number of copies you want using the touchpanel.

- 9 Press **Colour Start** or **Mono Start** to print the data.

- 10 Press .

#### IMPORTANT

- To prevent damage to your machine, **DO NOT** connect any device other than a digital camera or USB Flash memory drive to the USB direct interface.
- **DO NOT** remove the USB Flash memory drive or digital camera from the USB direct interface until the machine has finished printing.

## Changing the default settings for direct print

---

You can change the default settings for Direct Print.

- 1 Connect your USB Flash memory drive or digital camera to the USB direct interface on the front of the machine.
- 2 Press `Direct Print`.
- 3 Press `DefaultSettings`.
- 4 Swipe up or down, or press ▲ or ▼ to display the setting you want. Press the setting.
- 5 Press the new option you want. Repeat steps 4 and 5 for each setting you want to change.
- 6 Press `OK`.
- 7 Press .



## Printing a document

The machine can receive data from your computer and print it. To print from a computer, you must install the printer driver.

(For more information about printer driver settings, see Software User's Guide)

- 1 Install the Brother printer driver from the CD-ROM (see Quick Setup Guide).
- 2 From your application, choose the Print command.
- 3 Choose the name of your machine in the **Print** dialog box and click **Properties** (or **Preferences**, depending on the application you are using).
- 4 Choose the settings you want to change in the **Properties** dialog box, and then click **OK**.
  - **Paper Size**
  - **Orientation**
  - **Copies**
  - **Media Type**
  - **Print Quality**
  - **Color / Mono**
  - **Document Type**
  - **Multiple Page**
  - **2-sided / Booklet**
  - **Paper Source**
- 5 Click **Print** to begin printing.

# 12

## How to scan to a computer

### Before scanning

To use the machine as a scanner, install a scanner driver. If the machine is on a network, configure it with a TCP/IP address.

- Install the scanner drivers from the CD-ROM (see Quick Setup Guide: *Install MFL-Pro Suite*).
- Configure the machine with a TCP/IP address if network scanning does not work (see Software User's Guide).

# Scanning a document as a PDF file using ControlCenter4 (Windows®)

(For Macintosh users, see Software User's Guide.)

## NOTE

The screens on your computer may vary depending on your model.

ControlCenter4 is a software utility that lets you quickly and easily access the applications you use most often. Using ControlCenter4 eliminates the need to manually launch specific applications. You can use ControlCenter4 on your computer.

- 1 Load your document (see *How to load documents* on page 34).
- 2 Follow the instructions for the operating system you are using.
  - (Windows® XP, Windows Vista® and Windows® 7)
 

Open ControlCenter4 by clicking  (Start) > All Programs > Brother > XXX-XXXX (where XXX-XXXX is your model name) > **ControlCenter4**. The ControlCenter4 application will open.
  - (Windows® 8)
 

Click  (**Brother Utilities**), and then click the drop-down list and select your model name (if not already selected). Click **SCAN** in the left navigation bar, and then click **ControlCenter4**. The ControlCenter4 application will open.
- 3 If the ControlCenter4 Mode screen appears, choose the **Advanced Mode** and then click **OK**.

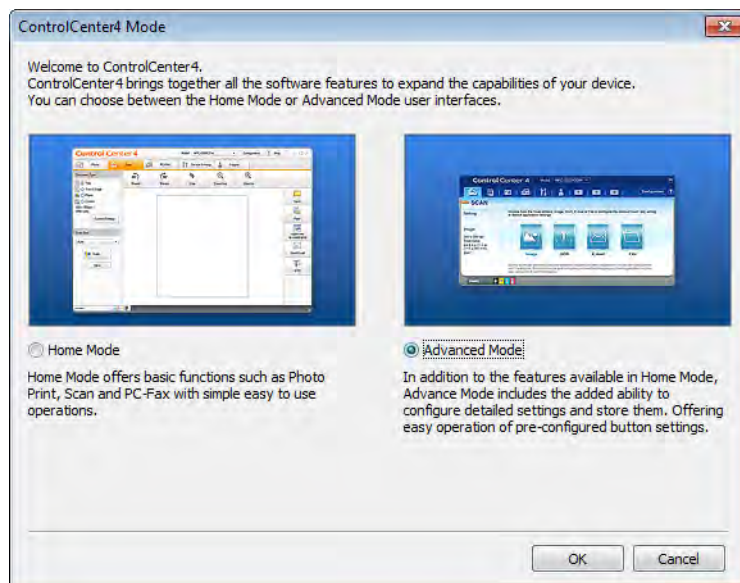

- 4 Make sure the machine you want to use is selected from the **Model** drop-down list.
- 5 Click **File**.

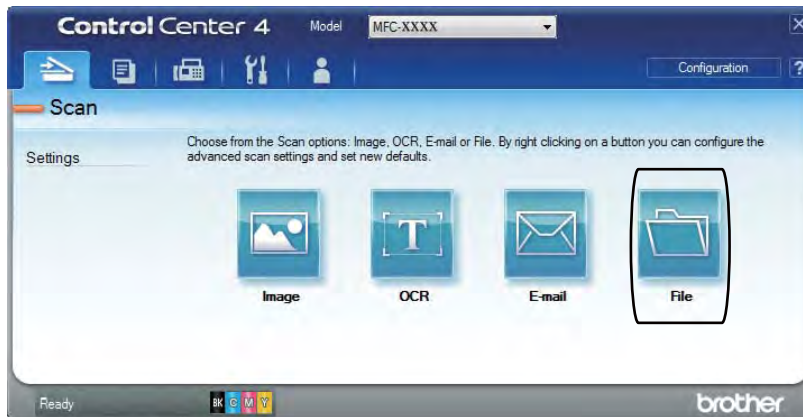

- 6 Press **Scan**.  
The machine starts the scanning process. The folder where the scanned data is saved will open automatically.

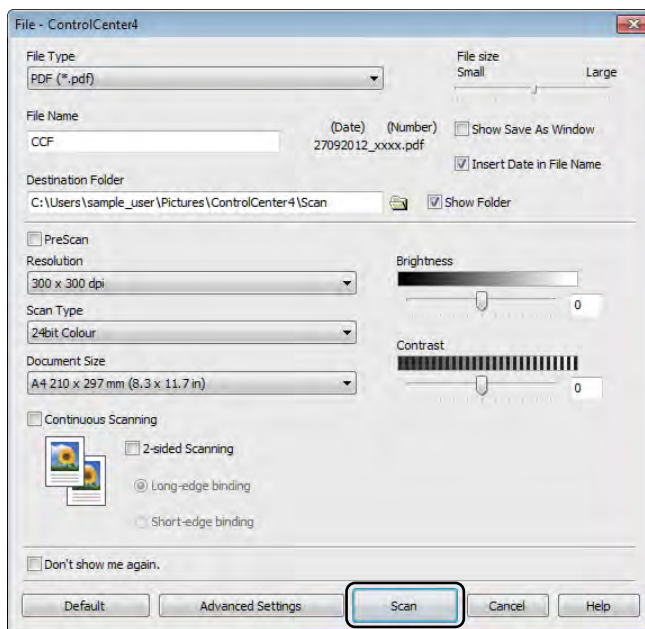

# How to scan a document as a PDF file using the Touchscreen

- 1 Load your document (see *How to load documents* on page 34).
- 2 Press Scan.



- 3 Swipe left or right to display to File.



will be displayed in the centre of the Touchscreen highlighted in blue.

- 4 Press OK.  
When the machine is connected to a network, press the computer name.  
Do one of the following:
  - If you want to use the default settings, go to step 9.
  - If you want to change the default settings, go to step 5.

- 5 Press Options.

- 6 Press Set with Touch Panel.  
Press On.

- 7 Choose the settings for 2-sided Scan<sup>1</sup>, Scan Type, Resolution, File Type, Scan Size and Remove Background Colour as needed.

- 8 Press OK.

- 9 Press Start.  
The machine starts the scanning process.

<sup>1</sup> MFC-9340CDW

## NOTE

---

The following scan modes are available.

- to USB (MFC-9340CDW)
- to Network (Windows®)
- to FTP
- to E-mail Server
- to E-mail
- to Image
- to OCR
- to File
- WS Scan<sup>1</sup> (Web Services Scan)

---

<sup>1</sup> Windows® users only (Windows Vista® SP2 or later, Windows® 7 and Windows® 8)  
(See Software User's Guide.)

# A

## Routine maintenance

### Replacing the consumable items

You must replace the consumable items when the machine indicates that the life of the consumable is over. You can replace the following consumable items by yourself:

Using non-Brother supplies may affect the print quality, hardware performance, and machine reliability.

#### NOTE

The drum unit and toner cartridge are two separate consumables. Make sure both are installed as an assembly. If the toner cartridge is placed in the machine without the drum unit, the message **Drum !** may be displayed.

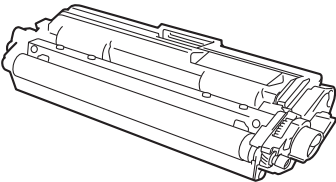
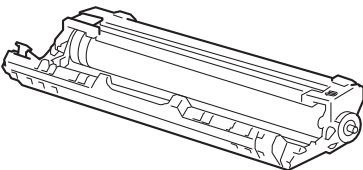
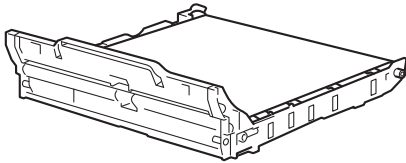
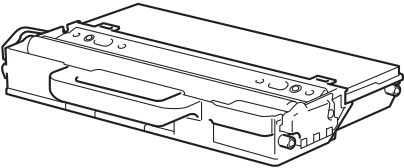
Toner cartridge	Drum unit
<p>See <i>Replacing the toner cartridges</i> on page 73.</p> <p>Model Name: TN-281BK, TN-285C, TN-285M, TN-285Y</p>	<p>See <i>Replacing the drum units</i> on page 80.</p> <p>Model Name: DR-281CL (4 pc. drum set) or DR-281CL-BK, DR-281CL-CMY (single drums)</p>
	
Belt unit	Waste toner box
<p>See <i>Replacing the belt unit</i> on page 86.</p> <p>Model Name: BU-220CL</p>	<p>See <i>Replacing the waste toner box</i> on page 90.</p> <p>Model Name: WT-220CL</p>
	

The messages in the table appear on the Touchscreen in Ready mode. These messages provide advanced warnings to replace the consumable items before they reach end of life. To avoid any inconvenience, you may want to buy spare consumable items before the machine stops printing.

Touchscreen messages	Consumable item to prepare	Approximate life	How to replace	Model name
Toner Low Prepare New Toner Cartridge.	Toner cartridge BK = Black C = Cyan M = Magenta Y = Yellow	<Black> 2,500 pages <sup>1 2</sup> <Cyan, Magenta, Yellow> 2,200 pages <sup>1 2</sup>	See page 73.	TN-281BK TN-285C TN-285M TN-285Y
Drum End SoonX	1 Drum unit X = BK, C, M, Y BK = Black C = Cyan M = Magenta Y = Yellow	15,000 pages <sup>1 3 4</sup>	See page 81.	4 Drum units: DR-281CL  1 Drum unit: DR-281CL-BK DR-281CL-CMY
Belt End Soon	Belt unit	50,000 pages <sup>1</sup>	See page 86.	BU-220CL
WT Box End Soon	Waste toner box	50,000 pages <sup>1</sup>	See page 90.	WT-220CL

<sup>1</sup> A4 or Letter size single-sided pages.

<sup>2</sup> Approx. cartridge yield is declared in accordance with ISO/IEC 19798.

<sup>3</sup> 1 page per job

<sup>4</sup> Drum life is approximate and may vary by type of use.



You must clean the machine regularly and replace the consumable items when the messages in the table are displayed on the Touchscreen.

Touchscreen messages	Consumable item to replace	Approximate life	How to replace	Model name
Replace Toner	Toner cartridge  The Touchscreen shows the toner cartridge colour that you must replace.  BK = Black C = Cyan M = Magenta Y = Yellow	<Black>  2,500 pages <sup>1 2</sup>  <Cyan, Magenta, Yellow>  2,200 pages <sup>1 2</sup>	See page 73.	TN-281BK  TN-285C  TN-285M  TN-285Y
Replace DrumX	Drum unit  X = BK, C, M, Y  BK = Black  C = Cyan  M = Magenta  Y = Yellow	15,000 pages <sup>1 3 4</sup>	See page 81.	4 Drum units: DR-281CL  1 Drum unit: DR-281CL-BK DR-281CL-CMY
Drum Stop	Drum unit			
Replace Belt	Belt unit	50,000 pages <sup>1</sup>	See page 86.	BU-220CL
Replace WT Box	Waste toner box	50,000 pages <sup>1</sup>	See page 90.	WT-220CL
Replace Fuser	Fuser unit	50,000 pages <sup>1</sup>	Contact Brother customer service or your local Brother dealer for a replacement fuser unit.	
Replace PF kit	Paper feeding kit	50,000 pages <sup>1</sup>	Contact Brother customer service or your local Brother dealer for a replacement paper feeding kit.	

<sup>1</sup> A4 or Letter size single-sided pages.

<sup>2</sup> Approx. cartridge yield is declared in accordance with ISO/IEC 19798.

<sup>3</sup> 1 page per job

<sup>4</sup> Drum life is approximate and may vary by type of use.

## NOTE

---

- Discard used consumable items according to local regulations, keeping it separate from domestic waste. If you have questions, call your local waste disposal office. Be sure to reseal the consumable items tightly so that the material inside does not spill.
  - We recommend placing used consumable items on a piece of paper to prevent accidentally spilling or scattering the material inside.
  - If you use paper that is not a direct equivalent for the recommended paper, the life of consumable items and machine parts may be reduced.
  - The projected life for each of the toner cartridges is based on ISO/ICE 19798. Frequency of replacement will vary depending on the print volume, percentage of coverage, types of media used, and powering on/off the machine.
  - Frequency of replacement consumables except toner cartridges will vary depending on the print volume, types of media used, and powering on/off the machine.
-

## Replacing the toner cartridges

---

Model Name: TN-281BK, TN-285C, TN-285M, TN-285Y

The toner cartridge can print approximately 2,500 pages<sup>1</sup> (Black) or approximately 2,200 pages<sup>1</sup> (Cyan, Magenta, Yellow). Actual page count will vary depending on your average type of document.

When a toner cartridge is running low, the Touchscreen shows **Toner Low**.

The toner cartridges that come supplied with the machine must be replaced after approximately 2,500 pages<sup>1</sup> (Black) or approximately 2,200 pages<sup>1</sup> (Cyan, Magenta, Yellow).

<sup>1</sup> Approx. cartridge yield is declared in accordance with ISO/IEC 19798.

### NOTE

---

- The indication of remaining toner life will vary depending on the types of documents printed and customer's usage.
  - It is a good idea to keep a new toner cartridge ready for use when you see the **Toner Low** warning.
  - To ensure high quality printing, we recommend that you use only Brother Original toner cartridges. When you want to buy toner cartridges, contact Brother customer service or your local Brother dealer.
  - We recommend that you clean the machine when you replace the toner cartridge (see *Cleaning and Checking the machine* on page 95).
  - **DO NOT** unpack the new toner cartridge until you are ready to install it.
- 

## Toner Low

If the Touchscreen shows **Toner Low**, buy a new toner cartridge for the colour indicated on the Touchscreen and have it ready before you get a **Replace Toner** message.

### Replace Toner

When the Touchscreen shows **Replace Toner** the machine will stop printing until you replace the toner cartridge.

The Touchscreen shows the toner cartridge colour that you must replace. (BK=Black, C=Cyan, M=Magenta, Y=Yellow).

A new Brother Original toner cartridge will reset the **Replace Toner** message.

## Replacing the toner cartridges

- 1 Make sure the machine is turned on.
- 2 Open the top cover until it locks in the open position.

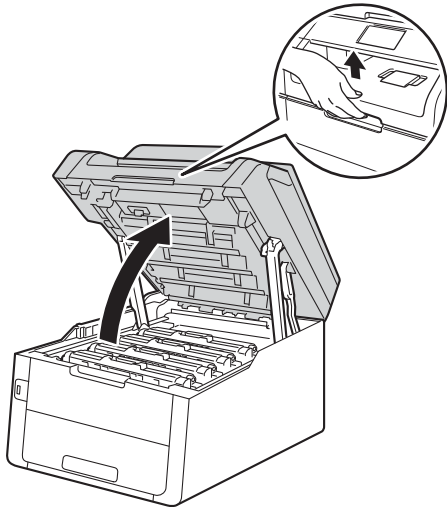

- 3 Remove the toner cartridge and drum unit assembly for the colour shown on the Touchscreen.

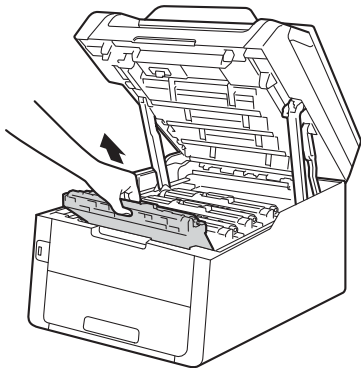

## WARNING

### HOT SURFACE

After you have just used the machine, some internal parts of the machine will be extremely hot. Wait for the machine to cool down before you touch the internal parts.

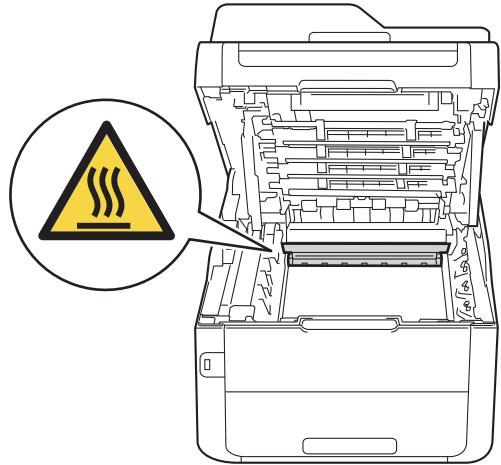

## IMPORTANT

- We recommend that you place the toner cartridge and drum unit assembly on a clean, flat surface with disposable paper underneath it in case you accidentally spill or scatter toner.
- To prevent damage to the machine from static electricity, **DO NOT** touch the electrodes shown in the illustration.

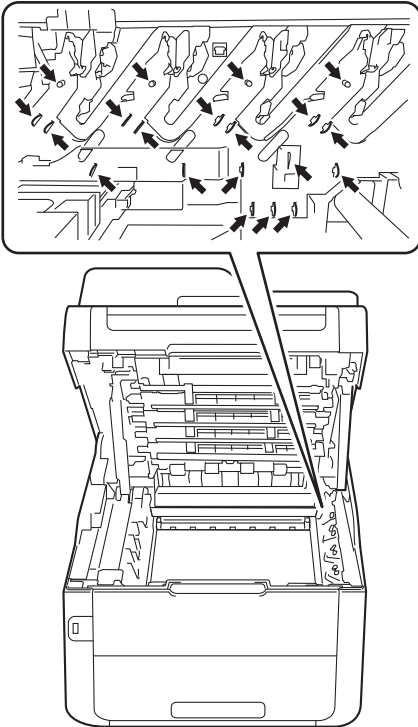

- 4 Push down the green lock lever and take the toner cartridge out of the drum unit.

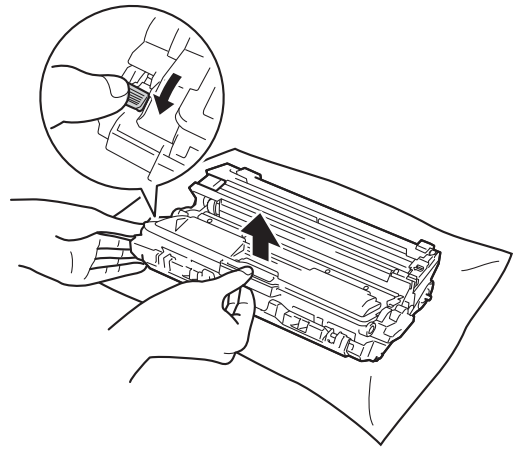

## ! WARNING



- **DO NOT** put a toner cartridge or a toner cartridge and drum unit assembly into a fire. It could explode, resulting in injuries.
- **DO NOT** use flammable substances, any type of spray, or an organic solvent/liquid containing alcohol or ammonia to clean the inside or outside of the product. Doing so could cause a fire or electrical shock. Instead, use only a dry, lint-free cloth.

(See Product Safety Guide: *General precautions.*)



## IMPORTANT

- Handle the toner cartridge carefully. If toner scatters on your hands or clothes, immediately wipe or wash it off with cold water.
- To avoid print quality problems, DO NOT touch the shaded parts shown in the illustrations.

### <Toner cartridge>

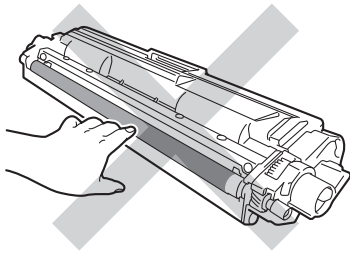

### <Drum unit>

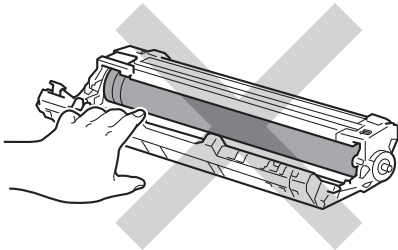
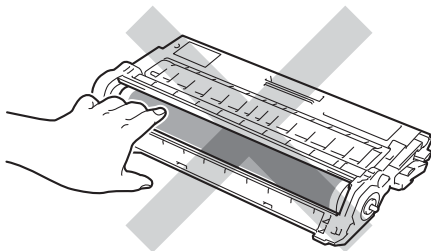

- We recommend that you place the toner cartridge on a clean, flat, level, stable surface with disposable paper underneath it in case you accidentally spill or scatter toner.

## NOTE

- Be sure to seal up the used toner cartridge tightly in a bag so that toner powder does not spill out of the cartridge.
- Discard used consumable items according to local regulations, keeping it separate from domestic waste. If you have questions, call your local waste disposal office. Be sure to reseal the consumable items tightly so that the material inside does not spill.

- 5 Unpack the new toner cartridge. Hold the cartridge level with both hands and gently shake it from side to side several times to spread the toner evenly inside the cartridge.

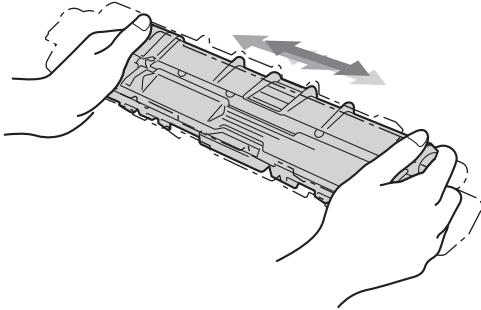

### IMPORTANT

- Unpack the toner cartridge just before you put it in the machine. If a toner cartridge is left unpacked for a long time, the toner life will be shortened.
- If an unpacked drum unit is placed in direct sunlight (or room light for long periods of time), the unit may be damaged.
- Brother machines are designed to work with toner of a particular specification and will work to a level of optimum performance when used with Brother Original toner cartridges. Brother cannot guarantee this optimum performance if toner or toner cartridges of other specifications are used. Brother does not therefore recommend the use of cartridges other than Brother Original cartridges with this machine, or the refilling of empty cartridges with toner from other sources. If damage is caused to the drum unit or other parts of this machine as a result of the use of toner or toner cartridges other than Brother Original products due to the incompatibility or lack of suitability of those products with this machine, any repairs required as a result may not be covered by the warranty.

- 6 Pull off the protective cover.

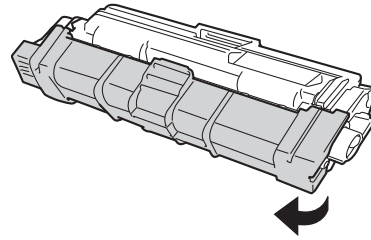

### IMPORTANT

Put the new toner cartridge in the drum unit immediately after you remove its protective cover. To prevent any degradation to the print quality, **DO NOT** touch the shaded parts shown in the illustrations.

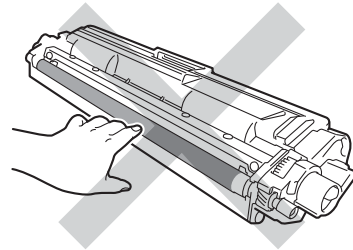

- 7 Put the new toner cartridge firmly into the drum unit until you hear it lock into place. If you put it in correctly, the green lock lever on the drum unit will lift automatically.

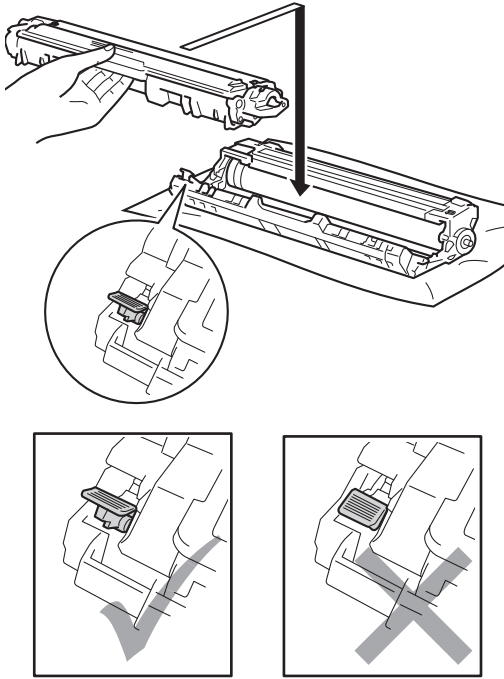

### NOTE

Make sure you put the toner cartridge in correctly or it may separate from the drum unit.

- 8 Clean the corona wire inside the drum unit by gently sliding the green tab from left to right and right to left several times.

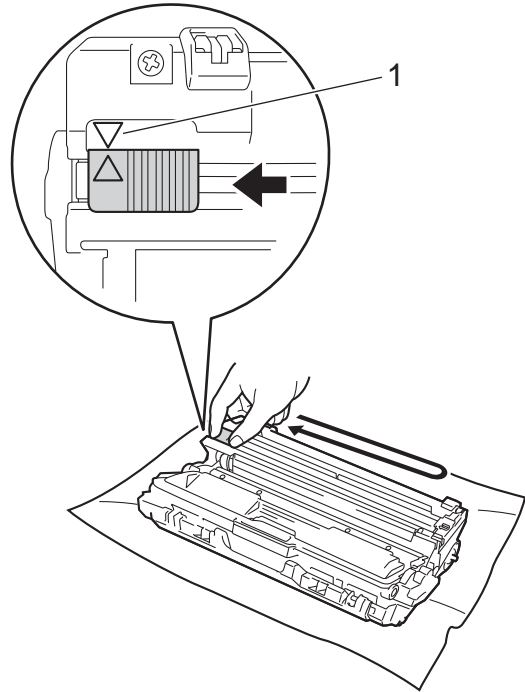

### NOTE

Be sure to return the tab to the Home position (▲) (1). The arrow on the tab must be aligned with the arrow on the drum unit. If it is not, printed pages may have a vertical stripe.

- 9 Repeat step 3 and step 8 to clean each of three remaining corona wires.

### NOTE

When cleaning the corona wires, you do not have to remove the toner cartridge from the drum unit.



- 10 Slide each toner cartridge and drum unit assembly into the machine. Make sure you match the toner cartridge colour to the same colour label on the machine.

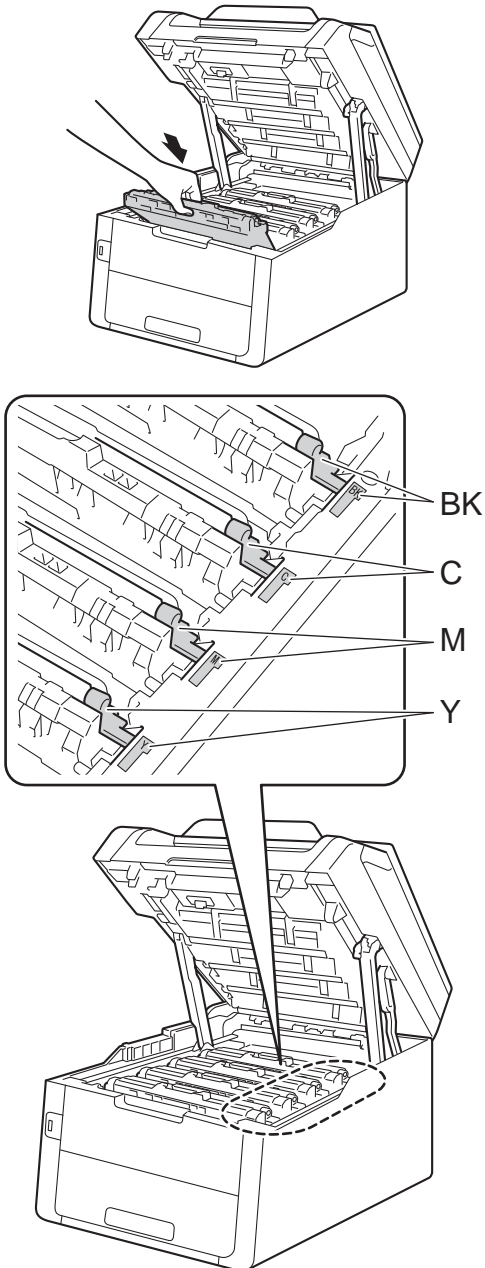

BK = Black, C = Cyan,  
M = Magenta, Y = Yellow

- 11 Close the top cover of the machine.

**NOTE**

After replacing a toner cartridge, DO NOT turn off the machine or open the top cover until the Touchscreen clears the Please wait. message and returns to Ready mode.

## Replacing the drum units

---

Model Name: DR-281CL 4 pc. Drum Set or single drum units DR-281CL-BK, DR-281CL-CMY

A new drum unit can print approximately 15,000 A4 or Letter size single-sided pages.

DR-281CL Drum Set contains four drum units, one Black (DR-281CL-BK) and three Colour (DR-281CL-CMY).

DR-281CL-BK contains one Black drum.  
DR-281CL-CMY contains one Colour drum.

Drum wear and tear occurs due to general use, rotation of the drum and interaction with paper, toner and other materials in the paper path. In designing this product, Brother decided to use the number of rotations of the drum as a reasonable determinant of the drum life. When a drum reaches the factory-established rotation limit corresponding to the rated page yield, the product's Touchscreen LCD will advise you to replace the applicable drum(s). The product will continue to function; however, print quality may not be optimal.

As the drums rotate in unison during the various stages of operation (regardless of whether toner is deposited on the page) and because damage to a single drum unit is not likely, you must replace all of the drums at once (unless you replaced an individual drum [DR-281CL-BK for Black and DR-281CL-CMY for Colour] for reasons other than reaching its rated life). For your convenience, Brother sells the drum units as a set of four (DR-281CL).

### IMPORTANT

---

For best performance, use a Brother Original drum unit and Brother Original toner units. Printing with a third-party drum unit or toner unit may reduce not only the print quality but also the quality and life of the machine itself. Warranty coverage may not apply to problems caused by the use of a third-party drum or toner unit.

---

### Drum !

The corona wires are dirty. Clean the corona wires in the four drum units (see *Cleaning the corona wires* on page 99).

If you cleaned the corona wires and the Drum ! error is still displayed on the Touchscreen, then the drum unit is at the end of its life. Replace the drum units with a new set.

### Drum End SoonX

If only a specified drum is near the end of its life, the Touchscreen shows the Drum End SoonX message. The X indicates the drum unit colour that is near the end of its life. (BK=Black, C=Cyan, M=Magenta, Y=Yellow). We recommend you keep Brother Original drum units ready for installation. Buy a new drum unit DR-281CL-BK (for Black) or a DR-281CL-CMY (for either C, M, Y colour) and have it ready before you get a Replace DrumX message.

### Replace DrumX

If only a specified drum needs to be replaced, the Touchscreen shows the Replace DrumX message. The X indicates the drum unit colour that you must replace. (BK=Black, C=Cyan, M=Magenta, Y=Yellow)

The drum unit has exceeded its rated life. Replace the drum unit with a new one. We recommend a Brother Original drum unit be installed at this time.

When you replace the drum unit with a new one, you must reset the drum counter. Instructions of how to do this can be found in the box your new drum unit came in.

## Drum Stop

We cannot guarantee the print quality. Replace the drum unit with a new one. We recommend a Brother Original drum unit be installed at this time.

When you replace the drum unit with a new one, you must reset the drum counter. Instructions of how to do this can be found in the box your new drum unit came in.

## Replacing the drum units

### IMPORTANT

- While removing the drum unit, handle it carefully because it may contain toner. If toner scatters on your hands or clothes, wipe or wash it off with cold water at once.
- Every time you replace the drum unit, clean the inside of the machine (see *Cleaning and Checking the machine* on page 95).
- DO NOT unpack the new drum unit until you are ready to install it. Exposure to direct sunlight (or room light for long periods of time) may damage the drum unit.

- 1 Make sure the machine is turned on.
- 2 Open the top cover until it locks in the open position.

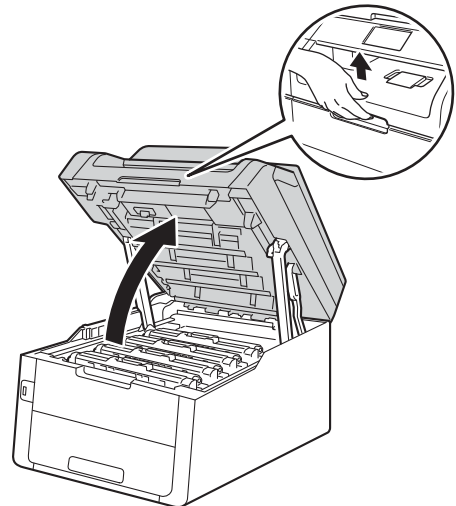

- 3 Remove the toner cartridge and drum unit assembly for the colour shown on the Touchscreen.

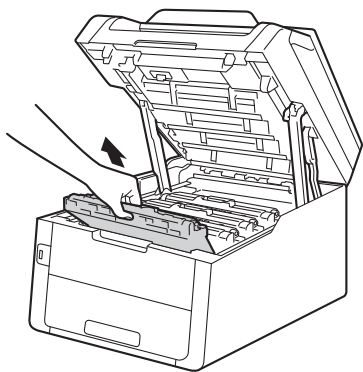

## ⚠ WARNING

### 🔥 HOT SURFACE

After you have just used the machine, some internal parts of the machine will be extremely hot. Wait for the machine to cool down before you touch the internal parts.

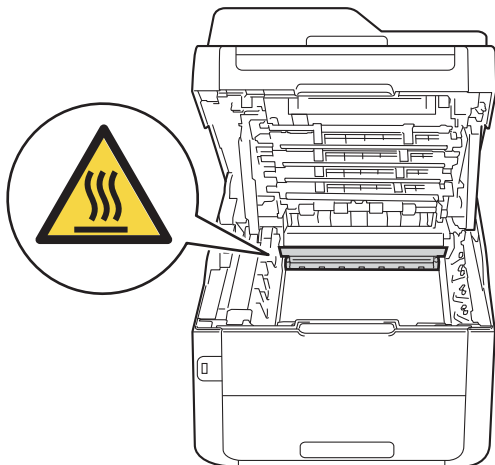

## IMPORTANT

- We recommend that you place the toner cartridge and drum unit assembly on a clean, flat surface with disposable paper underneath it in case you accidentally spill or scatter toner.
- To prevent damage to the machine from static electricity, DO NOT touch the electrodes shown in the illustration.

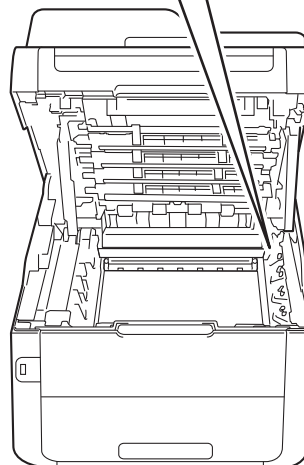
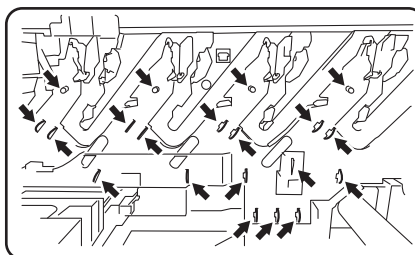

- 4 Push down the green lock lever and take the toner cartridge out of the drum unit.

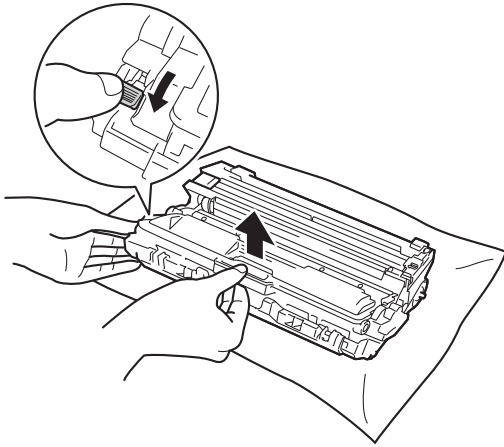

**! WARNING**



- DO NOT put a toner cartridge or a toner cartridge and drum unit assembly into a fire. It could explode, resulting in injuries.
- DO NOT use flammable substances, any type of spray, or an organic solvent/liquid containing alcohol or ammonia to clean the inside or outside of the product. Doing so could cause a fire or electrical shock. Instead, use only a dry, lint-free cloth.

(See Product Safety Guide: *General precautions*.)



**IMPORTANT**

- Handle the toner cartridge carefully. If toner scatters on your hands or clothes, immediately wipe or wash it off with cold water.
- To avoid print quality problems, DO NOT touch the shaded parts shown in the illustrations.

<Toner cartridge>

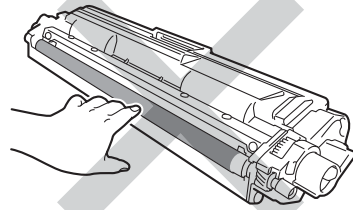

<Drum unit>

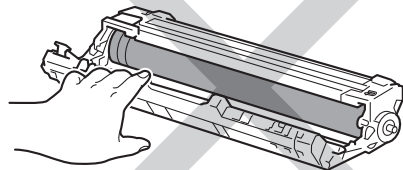
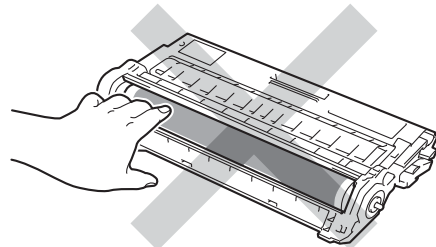

- We recommend that you place the toner cartridge on a clean, flat, level, stable surface with disposable paper underneath it in case you accidentally spill or scatter toner.

## NOTE

- Be sure to seal up the used drum unit tightly in a bag so that toner powder does not spill out of the drum unit.
- Discard used consumable items according to local regulations, keeping it separate from domestic waste. If you have questions, call your local waste disposal office. Be sure to reseal the consumable items tightly so that the material inside does not spill.

5 Unpack the new drum unit.

6 Pull off the protective cover.

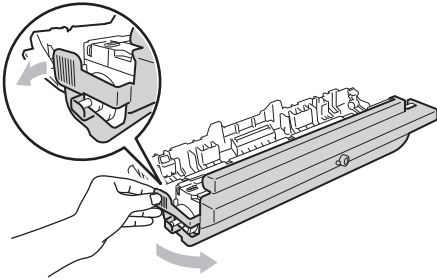

7 Put the toner cartridge firmly into the new drum unit until you hear it lock into place. If you put the cartridge in correctly, the green lock lever will lift automatically.

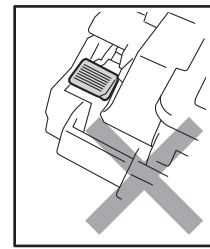
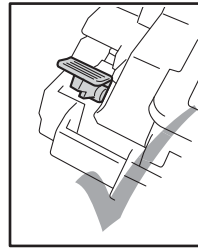
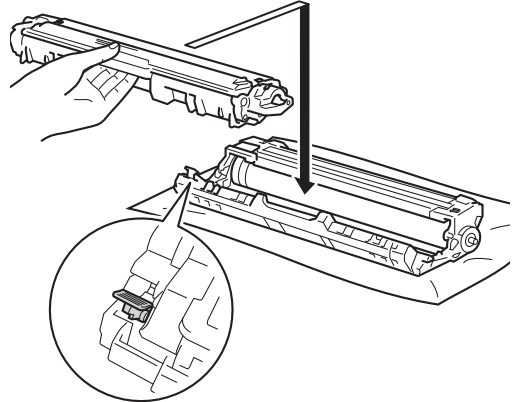

## NOTE

Make sure you put the toner cartridge in correctly or it may separate from the drum unit.

- 8 Clean the corona wire inside the drum unit by gently sliding the green tab from left to right and right to left several times.

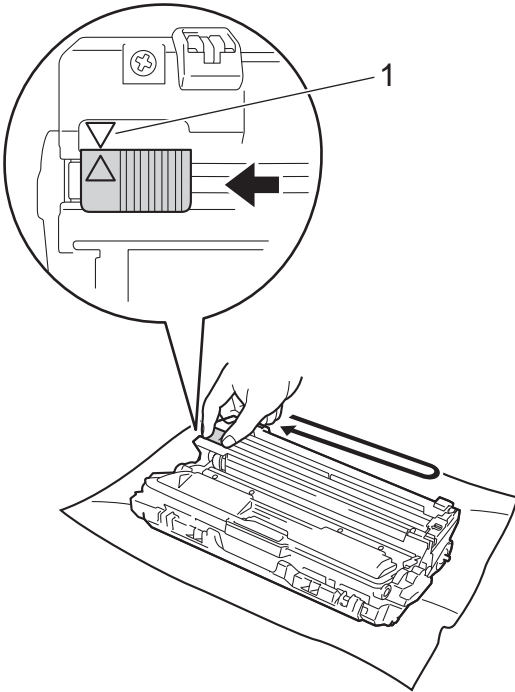

**NOTE**

Be sure to return the tab to the Home position (▲) (1). The arrow on the tab must be aligned with the arrow on the drum unit. If it is not, printed pages may have a vertical stripe.

- 9 Repeat step 3 and step 8 to clean each of the three remaining corona wires.

**NOTE**

When cleaning the corona wires, you do not have to remove the toner cartridge from the drum unit.

- 10 Slide each toner cartridge and drum unit assembly into the machine. Make sure you match the toner cartridge colour to the same colour label on the machine.

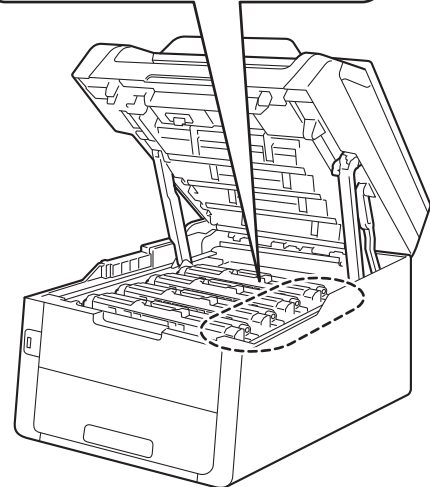
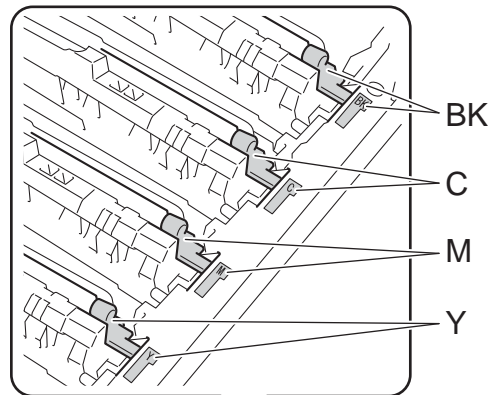
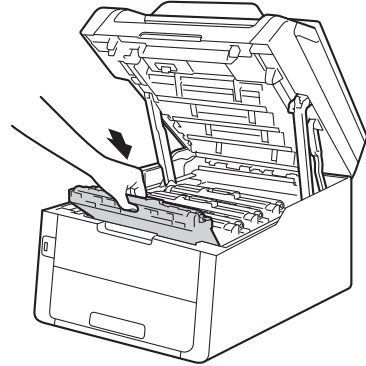

BK = Black, C = Cyan,  
M = Magenta, Y = Yellow

- 11 Close the top cover of the machine.
- 12 When you replace the drum unit with a new one, you must reset the drum counter. Instructions of how to do this can be found in the box your new drum unit came in.

## Replacing the belt unit

---

Model name: BU-220CL

A new belt unit can print approximately 50,000 A4 or Letter size single-sided pages.

### Replace Belt

When the `Replace Belt` message appears on the Touchscreen, you must replace the belt unit.

When you replace the belt unit with a new one, you must reset the belt unit counter. Instructions of how to do this can be found in the box your new belt unit came in.

### IMPORTANT

---

- DO NOT touch the surface of the belt unit. If you touch it, it could decrease print quality.
  - Damage caused by incorrect handling of the belt unit may void your warranty.
- 

- 1 Make sure the machine is turned on.
- 2 Open the top cover until it locks in the open position.

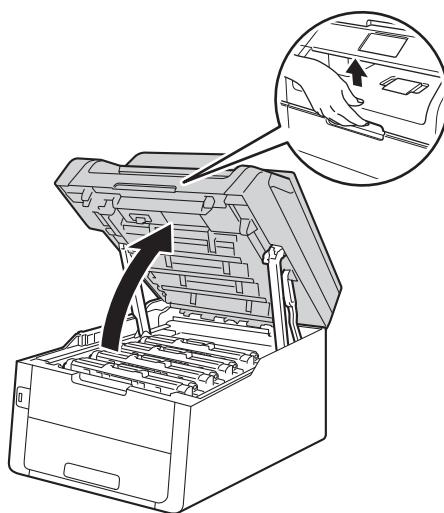



- 3 Remove all of the toner cartridge and drum unit assemblies.

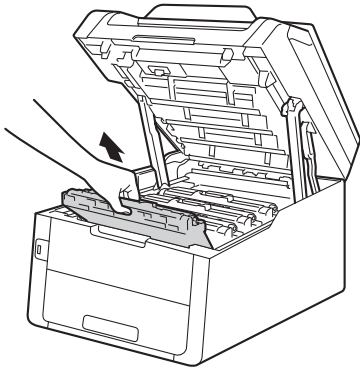

## ⚠ WARNING

### 🔥 HOT SURFACE

After you have just used the machine, some internal parts of the machine will be extremely hot. Wait for the machine to cool down before you touch the internal parts.

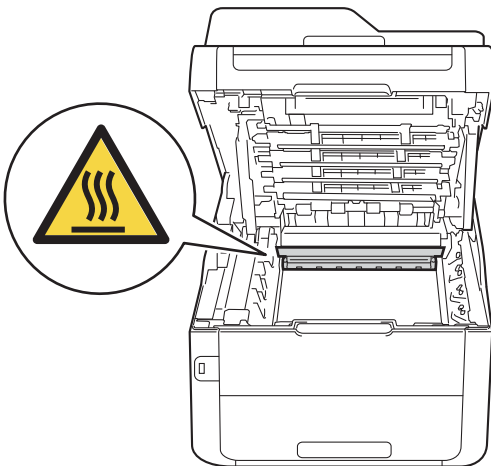

## IMPORTANT

- We recommend that you place the toner cartridge and drum unit assemblies on a clean, flat surface with disposable paper underneath them in case you accidentally spill or scatter toner.
- To prevent damage to the machine from static electricity, DO NOT touch the electrodes shown in the illustration.

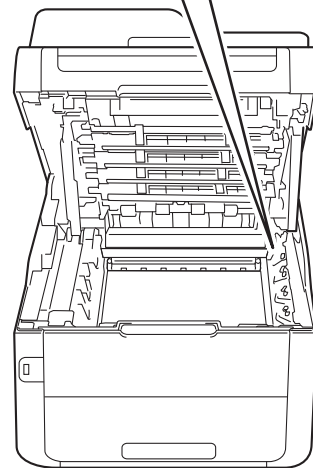
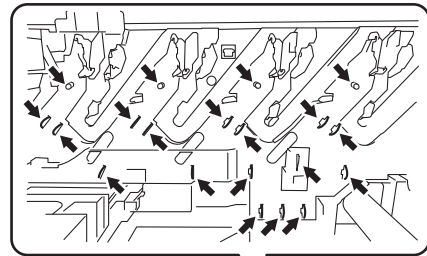

- 4 Hold the green handle of the belt unit and lift the belt unit up, and then pull it out.

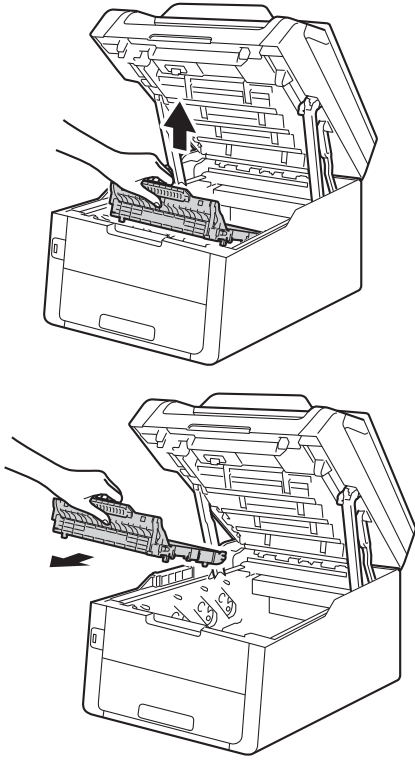

- 5 Unpack the new belt unit and put the new belt unit in the machine.

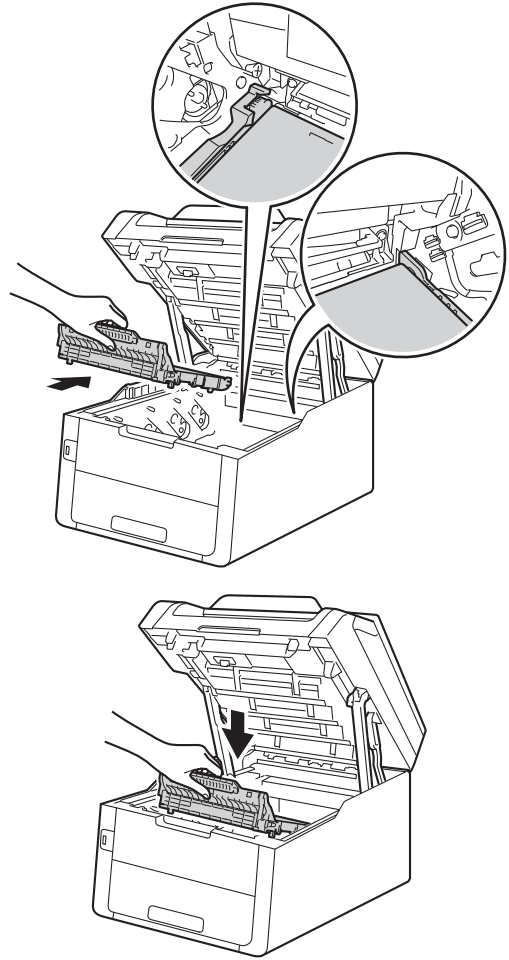

## IMPORTANT

To avoid print quality problems, **DO NOT** touch the shaded parts shown in the illustrations.

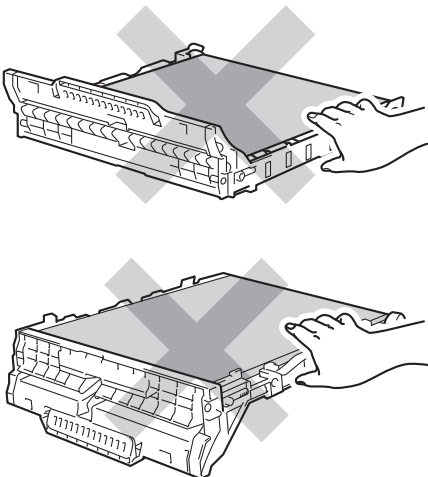

- 6 Slide each toner cartridge and drum unit assembly into the machine, making sure you match the toner cartridge colours to the same colour labels on the machine.

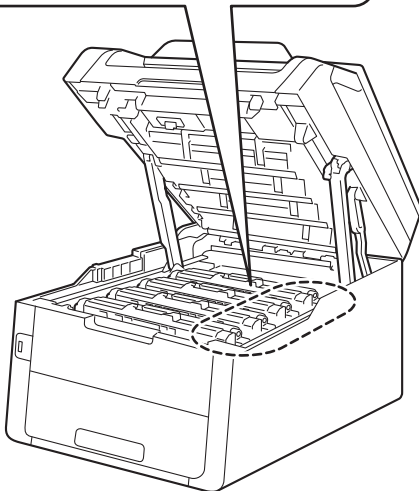
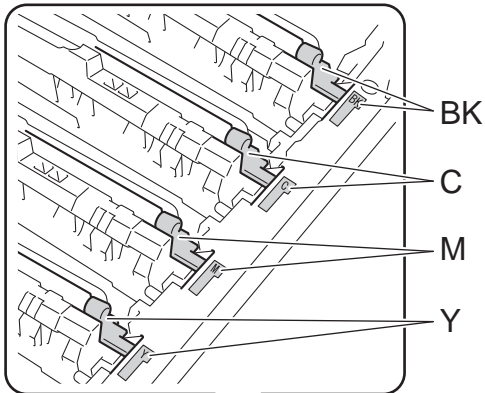
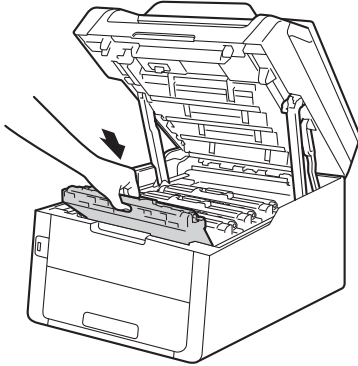

BK = Black, C = Cyan,  
M = Magenta, Y = Yellow

- 7 Close the top cover of the machine.
- 8 When you replace the belt unit with a new one, you must reset the belt unit counter. Instructions of how to do this can be found in the box your new belt unit came in.

## Replacing the waste toner box

Model name: WT-220CL

The life of a waste toner box is approximately 50,000 A4 or Letter size single-sided pages.

### WT Box End Soon

If the Touchscreen shows **WT Box End Soon**, it means the waste toner box is near the end of its life. Buy a new waste toner box and have it ready before you get a **Replace WT Box** message.

### Replace WT Box

When the **Replace WT Box** message appears on the Touchscreen, you must replace the waste toner box.

- 1 Make sure the machine is turned on.
- 2 Open the top cover until it locks in the open position.

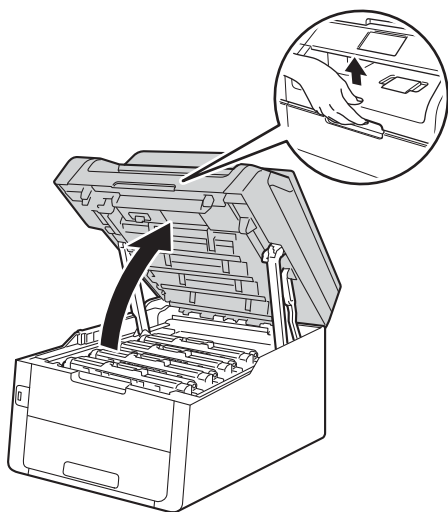

- 3 Remove all of the toner cartridge and drum unit assemblies.

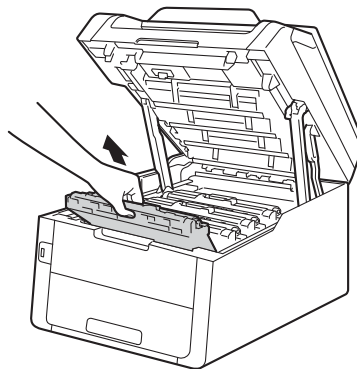

### ! WARNING

#### ! HOT SURFACE

After you have just used the machine, some internal parts of the machine will be extremely hot. Wait for the machine to cool down before you touch the internal parts.

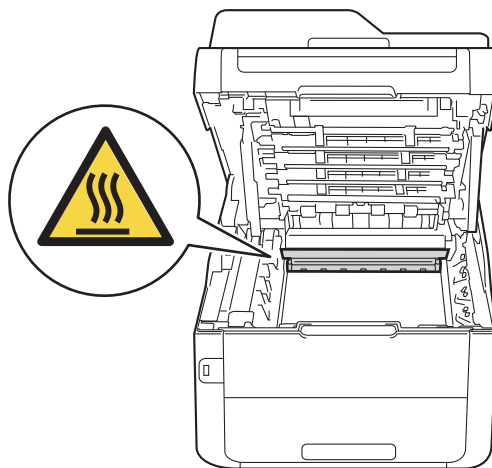

## IMPORTANT

- We recommend that you place the toner cartridge and drum unit assemblies on a clean, flat surface with disposable paper underneath them in case you accidentally spill or scatter toner.
- To prevent damage to the machine from static electricity, **DO NOT** touch the electrodes shown in the illustration.

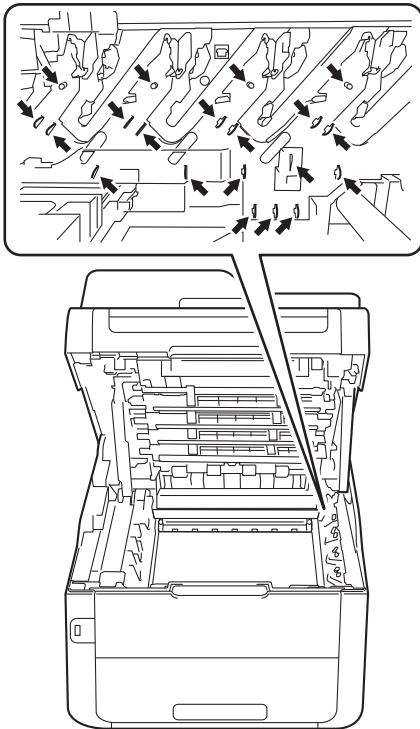

- 4 Hold the green handle of the belt unit and lift the belt unit up, and then pull it out.

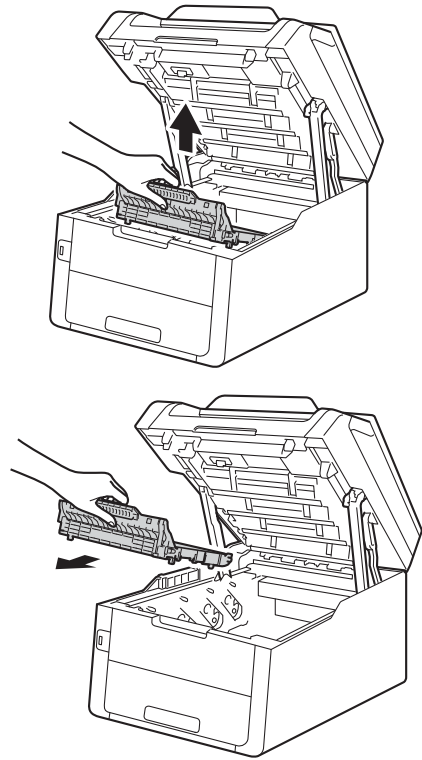

## IMPORTANT

To avoid print quality problems, **DO NOT** touch the shaded parts shown in the illustrations.

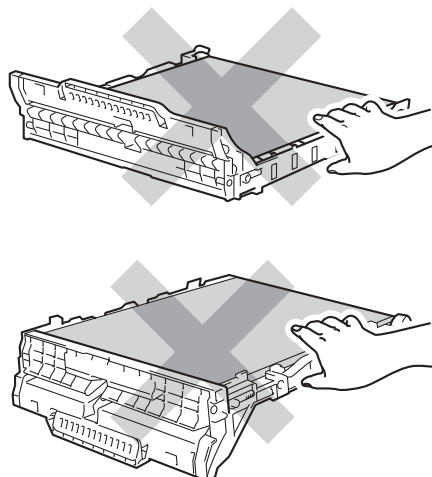

- 5 Remove the orange packing material and discard it.

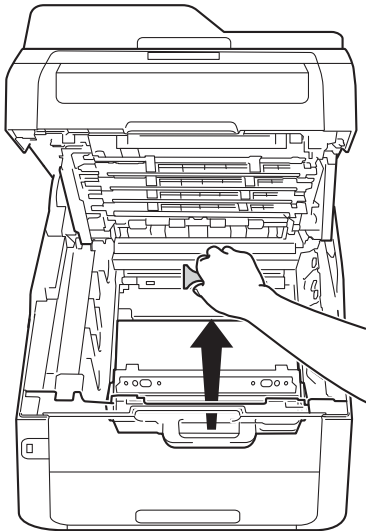
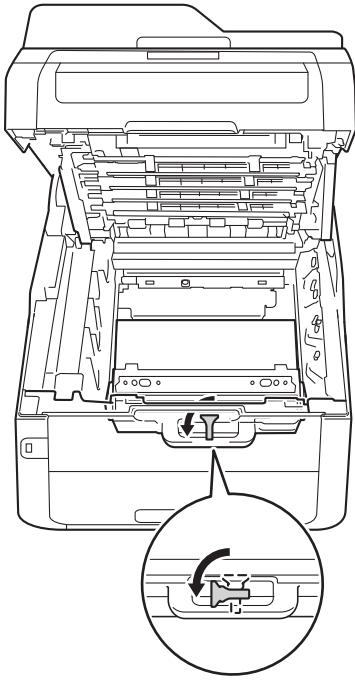

- 6 Hold the green handle of the waste toner box and remove the waste toner box from the machine.

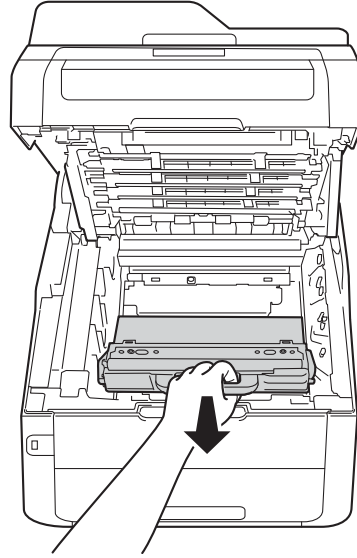

## NOTE

This step is only necessary when you are replacing the waste toner box for the first time, and is not required for the replacement waste toner box. The orange packing piece is installed at the factory to protect your machine during shipment.

**⚠ WARNING**

- DO NOT put the waste toner box into a fire. It could explode, resulting in injuries.
- DO NOT use flammable substances, any type of spray, or an organic solvent/liquid containing alcohol or ammonia to clean the inside or outside of the product. Doing so could cause a fire or electrical shock. Instead, use only a dry, lint-free cloth.

(See Product Safety Guide: *General precautions*.)

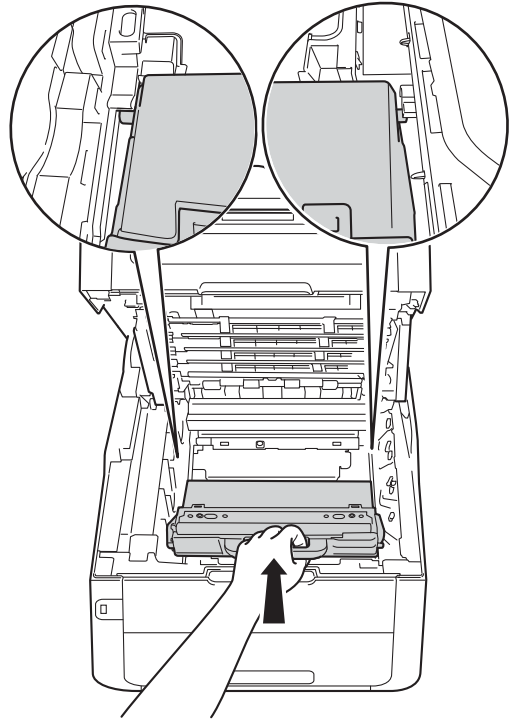

- 7** Unpack the new waste toner box and place it in the machine.

**IMPORTANT**

DO NOT reuse the waste toner box.

**NOTE**

- Be sure to seal up the waste toner box tightly in a bag so that toner powder does not spill out of the waste toner box.
- Discard the used waste toner box according to local regulations, keeping it separate from domestic waste. If you have questions, call your local waste disposal office.

- 8 Put the belt unit back in the machine.

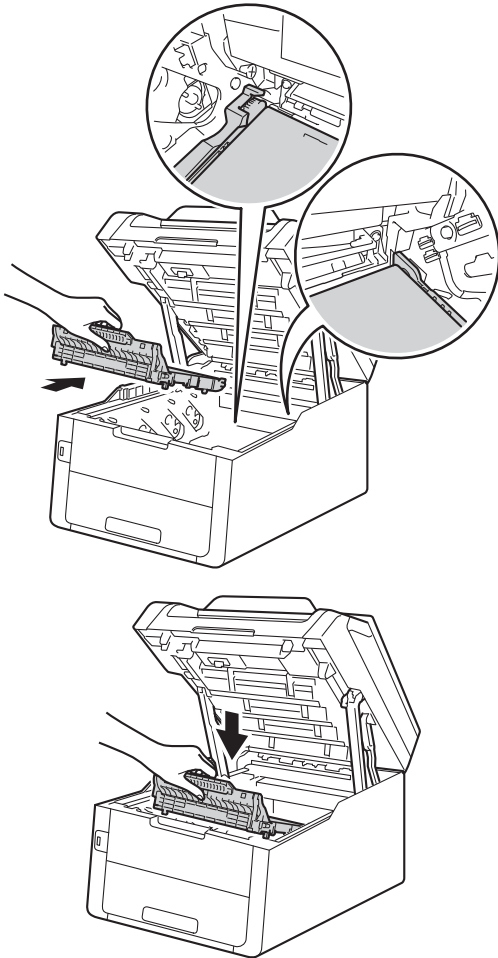

- 9 Slide each toner cartridge and drum unit assembly into the machine, making sure you match the toner cartridge colours to the same colour labels on the machine.

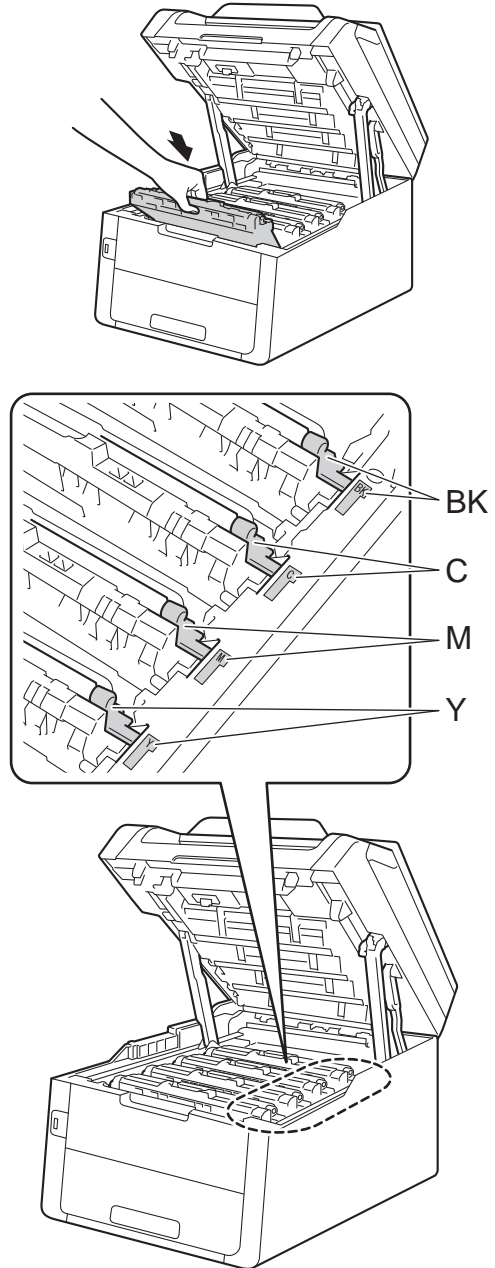

BK = Black, C = Cyan,  
M = Magenta, Y = Yellow

- 10 Close the top cover of the machine.



## Cleaning and Checking the machine

Clean the outside and inside of the machine regularly with a dry, lint-free cloth. When you replace the toner cartridge or the drum unit, make sure that you clean the inside of the machine. If printed pages are stained with toner, clean the inside of the machine with a dry, lint-free cloth.

### WARNING



- DO NOT put a toner cartridge or a toner cartridge and drum unit assembly into a fire. It could explode, resulting in injuries.
- DO NOT use flammable substances, any type of spray, or an organic solvent/liquid containing alcohol or ammonia to clean the inside or outside of the product. Doing so could cause a fire or electrical shock. Instead, use only a dry, lint-free cloth.

(See Product Safety Guide: *General precautions*.)



### IMPORTANT

- Use neutral detergents. Cleaning with volatile liquids such as thinner or benzene will damage the surface of the machine.
- DO NOT use cleaning materials that contain ammonia.
- DO NOT use isopropyl alcohol to remove dirt from the control panel. It may crack the panel.

## Cleaning the outside of the machine

### IMPORTANT

DO NOT use any type of liquid cleaners (including ethanol).

### Cleaning the Touchscreen

- 1 Press and hold down  to turn the machine off.
- 2 Clean the Touchscreen with a *dry*, soft lint-free cloth.

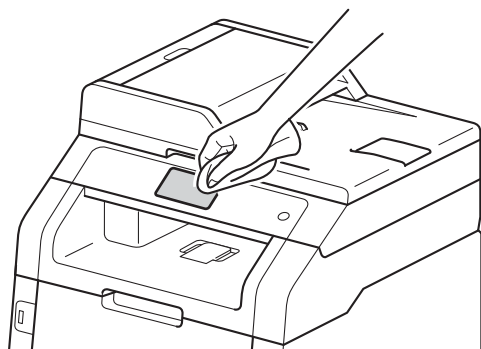

- 3 Turn on the machine.

### Cleaning the outside of the machine

- 1 Press and hold down  to turn the machine off.

- 2 Wipe the outside of the machine with a dry, lint-free cloth to remove dust.

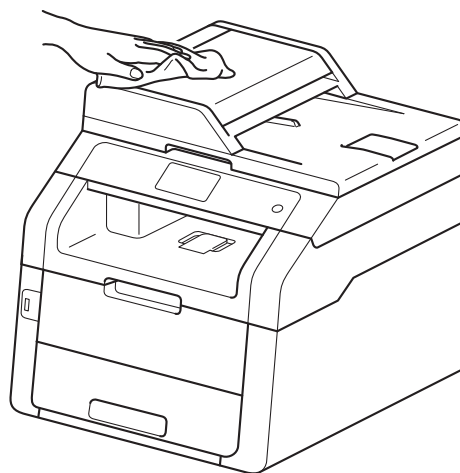

- 3 Pull the paper tray completely out of the machine.

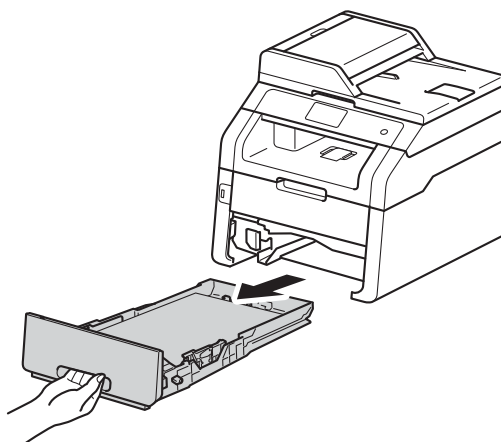

- 4 If paper is loaded in the paper tray, remove it.
- 5 Remove anything that is stuck inside the paper tray.

- 6 Wipe the inside and the outside of the paper tray with a dry, lint-free cloth to remove dust.

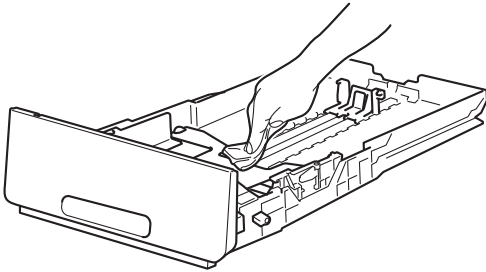

- 7 Re-load the paper and put the paper tray firmly back in the machine.
- 8 Turn on the machine.

## Cleaning the LED heads

If there is a problem with the print quality, such as light or faded colours or white streaks or bands down the page, clean the LED heads as follows:

### IMPORTANT

DO NOT touch the windows of the LED heads with your fingers.

- 1 Press and hold down  to turn the machine off.
- 2 Open the top cover until it locks in the open position.

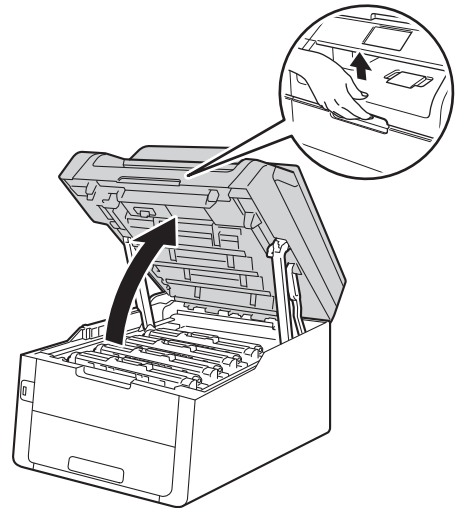

- 3 Wipe the windows of all four LED heads (1) with a dry, lint-free cloth. Be careful not to touch the windows of the LED heads (1) with your fingers.

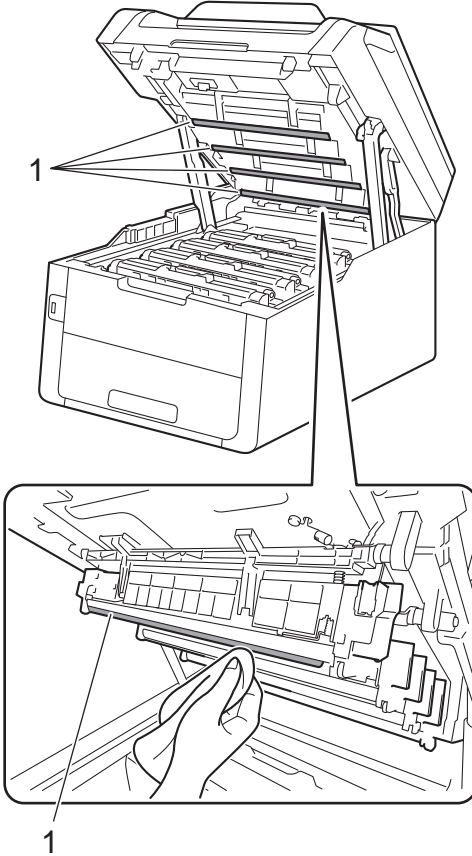

- 4 Close the top cover of the machine.  
5 Turn on the machine.

## Cleaning the scanner glass

- 1 Press and hold down  to turn the machine off.
- 2 (MFC-9340CDW)  
Unfold the ADF document support (1) and then open the ADF cover (2). Clean the white bar (3) and the scanner glass strip (4) underneath it with a soft lint-free cloth slightly moistened with water.  
Close the ADF cover (2) and fold the ADF document support (1).

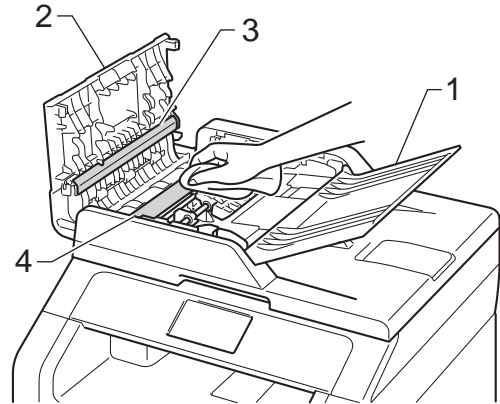

- 3 Lift the document cover (1). Clean the white plastic surface (2) and scanner glass (3) underneath it with a soft lint-free cloth slightly moistened with water.

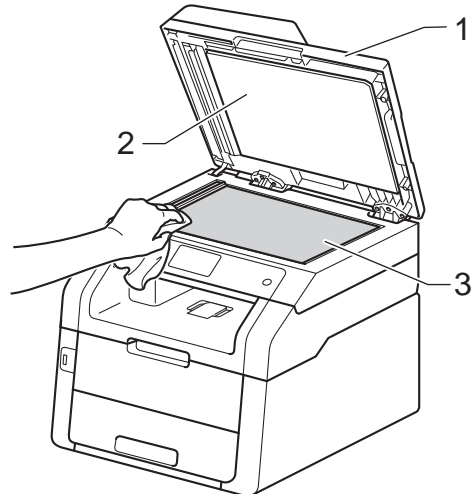

- 4 In the ADF unit, clean the white bar (1) and the scanner glass strip (2) underneath it with a soft lint-free cloth slightly moistened with water.

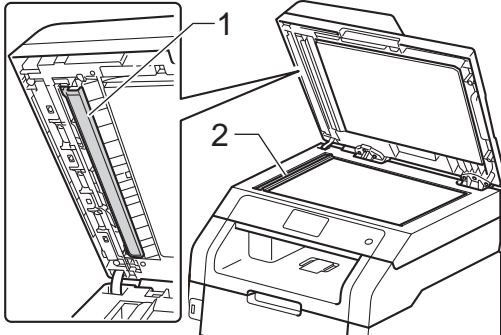

### NOTE

In addition to cleaning the scanner glass and glass strip with a soft lint-free cloth slightly moistened with water, run your finger tip over the glass to see if you can feel anything on it. If you feel dirt or debris, clean the glass again concentrating on that area. You may need to repeat the cleaning process three or four times. To test, make a copy after each cleaning.

- 5 Close the document cover.  
6 Turn on the machine.

## Cleaning the corona wires

If you have print quality problems or the Touchscreen shows **Drum !**, clean the corona wires as follows:

- 1 Open the top cover until it locks in the open position.

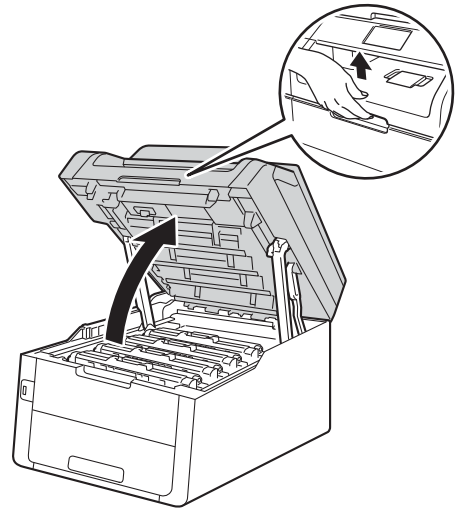

- 2 Remove the toner cartridge and drum unit assembly.

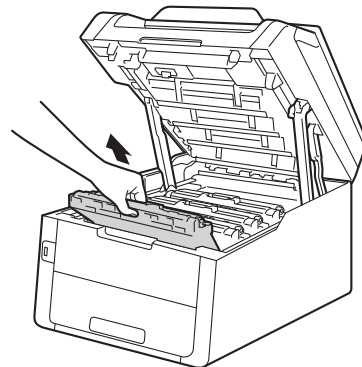

## WARNING

### HOT SURFACE

After you have just used the machine, some internal parts of the machine will be extremely hot. Wait for the machine to cool down before you touch the internal parts.

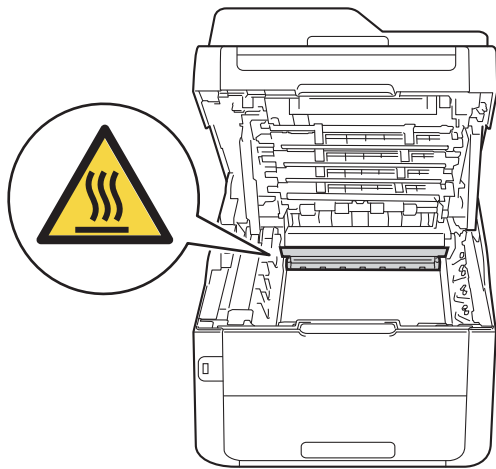

## IMPORTANT

- We recommend that you place the toner cartridge and drum unit assembly on a clean, flat surface with disposable paper underneath it in case you accidentally spill or scatter toner.
- To prevent damage to the machine from static electricity, **DO NOT** touch the electrodes shown in the illustration.

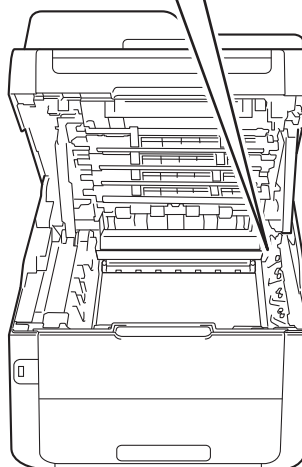
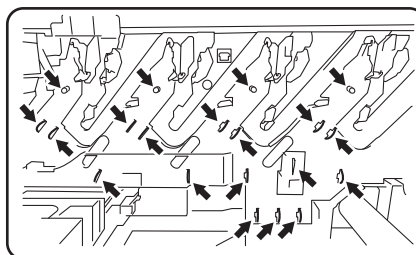

- 3 Clean the corona wire inside the drum unit by gently sliding the green tab from left to right and right to left several times.

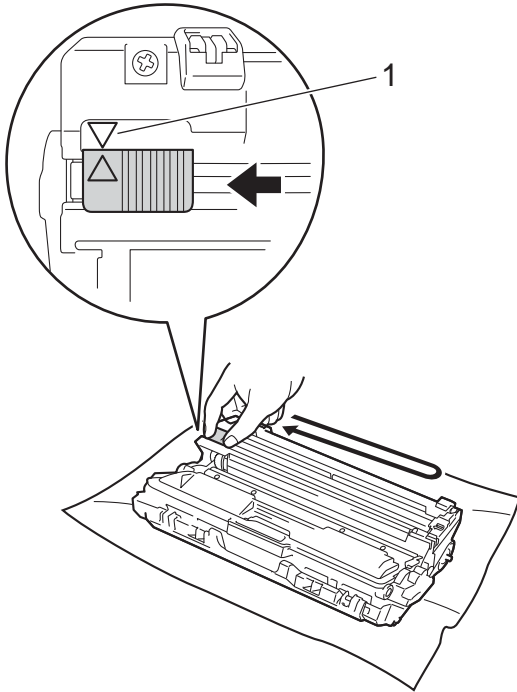

**NOTE**

Be sure to return the tab to the Home position (▲) (1). The arrow on the tab must be aligned with the arrow on the drum unit. If it is not, printed pages may have a vertical stripe.

- 4 Slide the toner cartridge and drum unit assembly into the machine. Make sure that you match the toner cartridge colour to the same colour label on the machine.

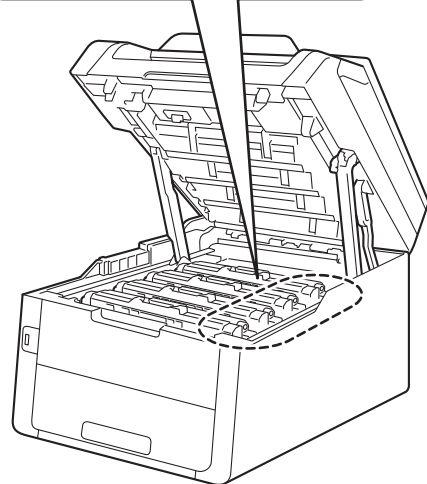
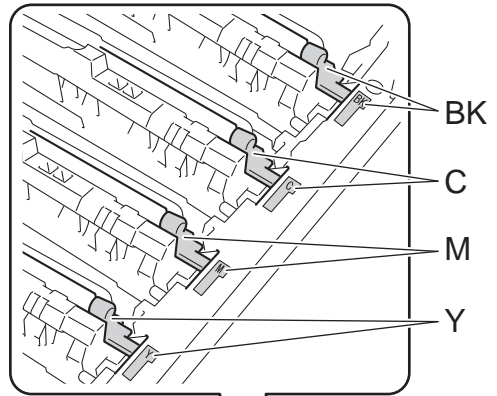
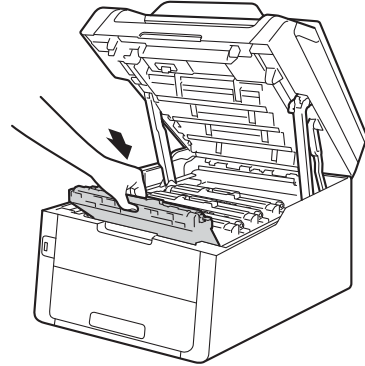

BK = Black, C = Cyan,  
M = Magenta, Y = Yellow

- 5 Repeat steps 2 - 4 to clean the three remaining corona wires.



## NOTE

When cleaning the corona wires, you do not have to remove the toner cartridge from the drum unit.

- 6 Close the top cover of the machine.

## Cleaning the drum unit

If your printout has dots at 94 mm intervals, follow the steps below to solve the problem.

- 1 Make sure that the machine is in the Ready mode.
- 2 Press .
- 3 Press All Settings.
- 4 Swipe up or down, or press ▲ or ▼ to display Print Reports.
- 5 Press Print Reports.
- 6 Swipe up or down, or press ▲ or ▼ to display Drum Dot Print.
- 7 Press Drum Dot Print.
- 8 The machine will display Press [OK]. Press OK.
- 9 The machine will print the Drum Dot Check Sheet. Then press .
- 10 Press and hold down  to turn the machine off.



- 11 Open the top cover until it locks in the open position.

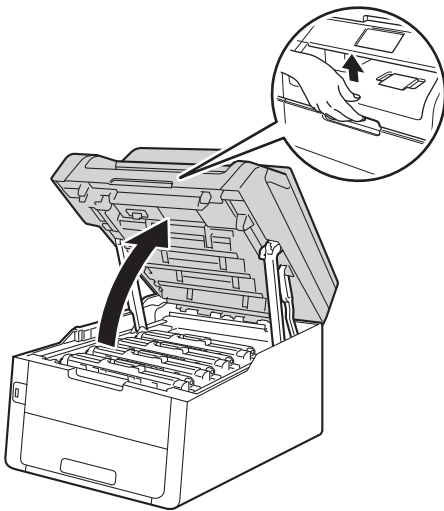

- 12 The colour of printed dots is the colour of the drum you should clean. Remove the toner cartridge and drum unit assembly of the colour causing the problem.

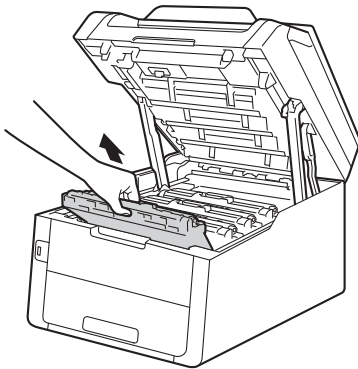

**! WARNING**

**! HOT SURFACE**

After you have just used the machine, some internal parts of the machine will be extremely hot. Wait for the machine to cool down before you touch the internal parts.

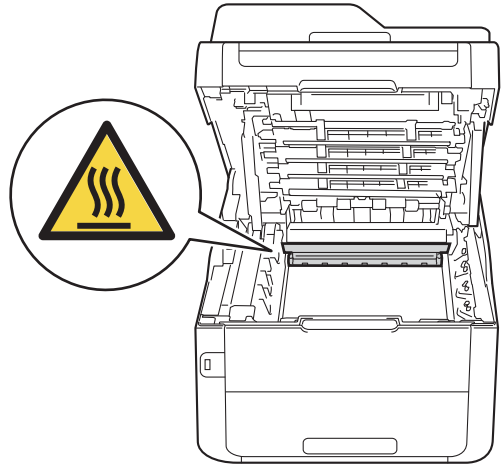

## IMPORTANT

- We recommend that you place the toner cartridge and drum unit assembly on a clean, flat surface with disposable paper underneath it in case you accidentally spill or scatter toner.
- To prevent damage to the machine from static electricity, DO NOT touch the electrodes shown in the illustration.

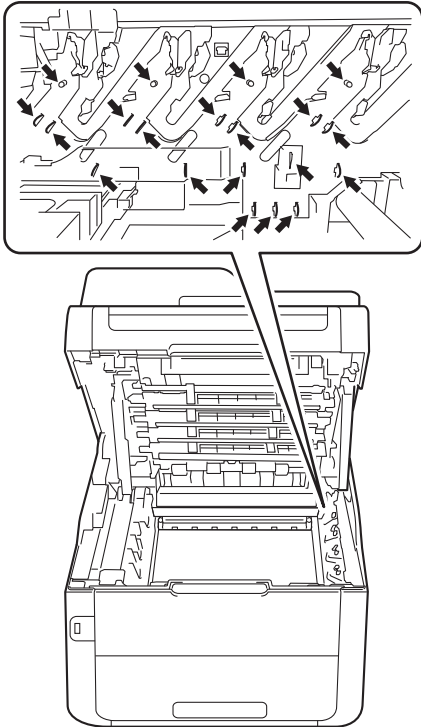

- 13 Push down the green lock lever and take the toner cartridge out of the drum unit.

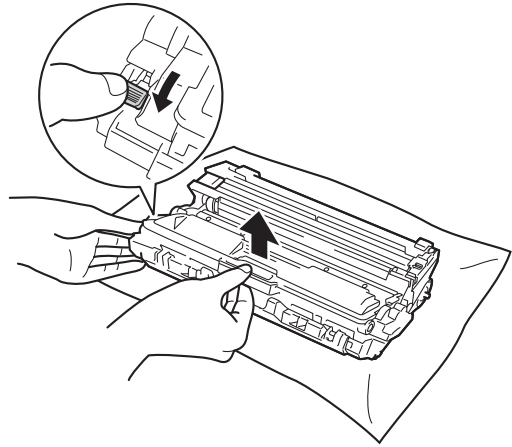

## IMPORTANT

- Handle the toner cartridge carefully. If toner scatters on your hands or clothes, immediately wipe or wash it off with cold water.
- To avoid print quality problems, DO NOT touch the shaded parts shown in the illustrations.

### <Toner cartridge>

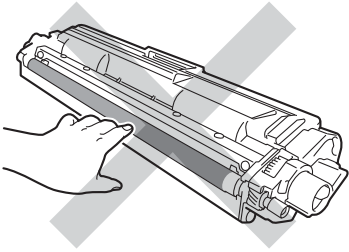

### <Drum unit>

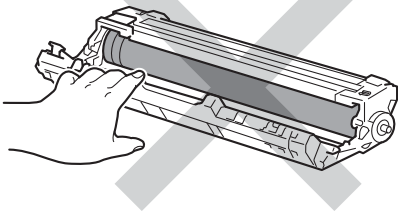
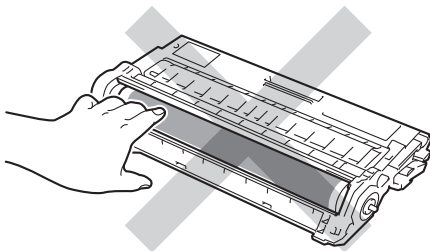

- We recommend that you place the toner cartridge on a clean, flat, level, stable surface with disposable paper underneath it in case you accidentally spill or scatter toner.

- 14 Turn the drum unit as shown in the illustration. Make sure that the drum unit gear (1) is on the left side.

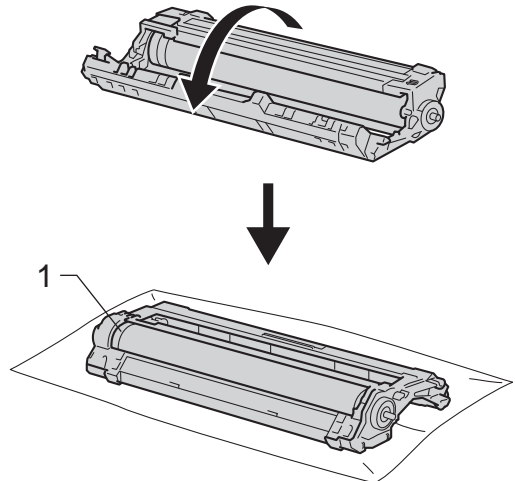

- 15 Read the following information from the Drum Dot Check Sheet.

■ Dot location:

The sheet has eight numbered columns. The number of the column with the printed dot in it is used to find the dot position on the drum.

- 16 Use the numbered markers next to the drum roller to find the mark. For example, a dot in column 2 on the Drum Dot Check Sheet would mean that there is a mark in the "2" region of the drum.

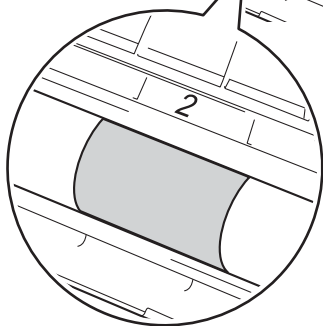
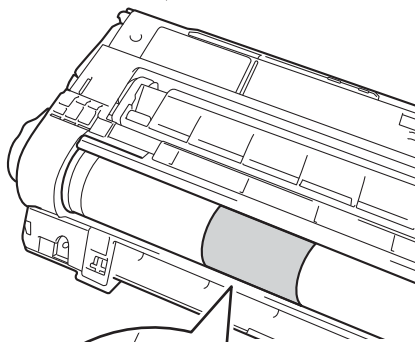
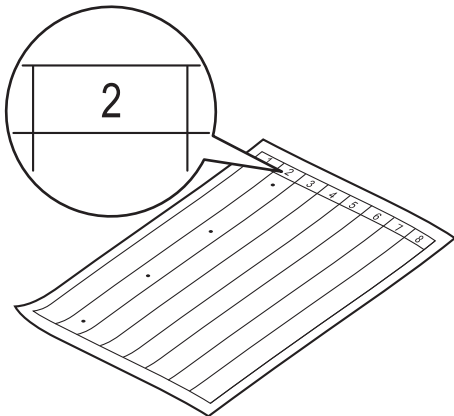

- 17 Turn the edge of the drum unit toward you by hand while looking at the surface of the suspected area.

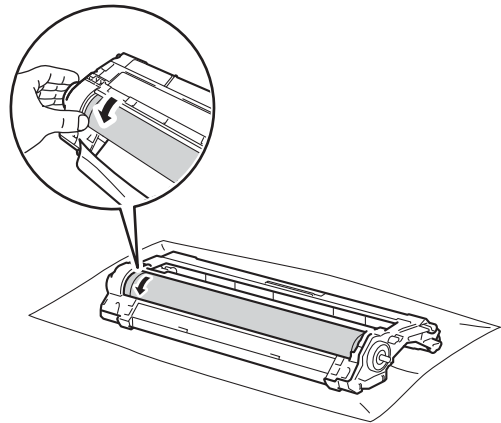

#### NOTE

DO NOT touch the drum's surface. To avoid print quality problems, hold the edges of the drum unit.

- 18 When you have found the mark on the drum that matches the Drum Dot Check Sheet, wipe the surface of the drum gently with a dry cotton swab until the mark on the surface comes off.

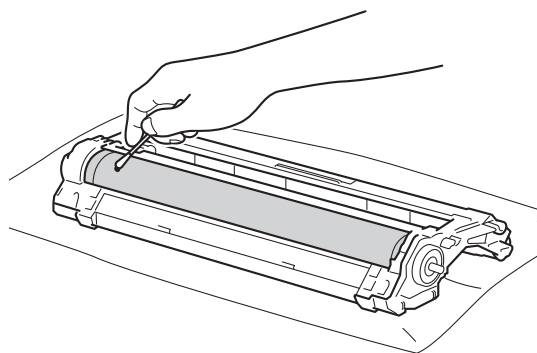

#### IMPORTANT

DO NOT clean the surface of the photosensitive drum with a sharp object or any liquids.

- 19 Turn the drum unit back over.

- 20 Put the toner cartridge firmly into the drum unit until you hear it lock into place. If you put the cartridge in correctly, the green lock lever will lift automatically.

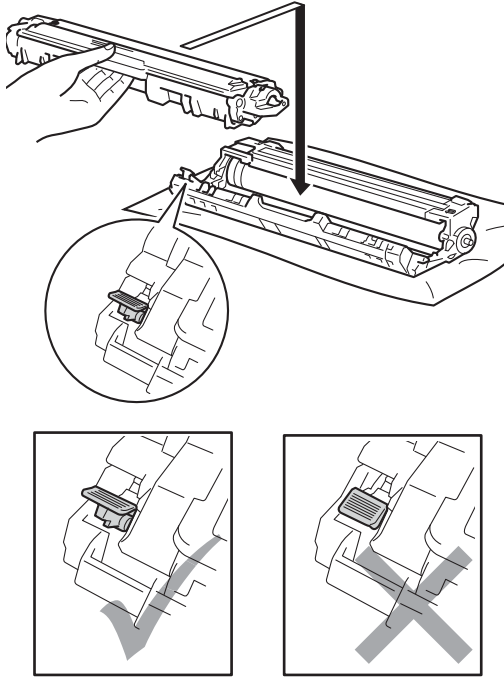

**NOTE**

Make sure you put the toner cartridge in correctly or it may separate from the drum unit.

- 21 Slide the toner cartridge and drum unit assembly into the machine. Make sure that you match the toner cartridge colour to the same colour label on the machine.

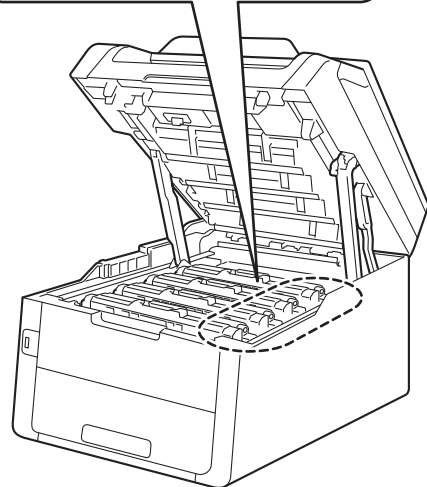
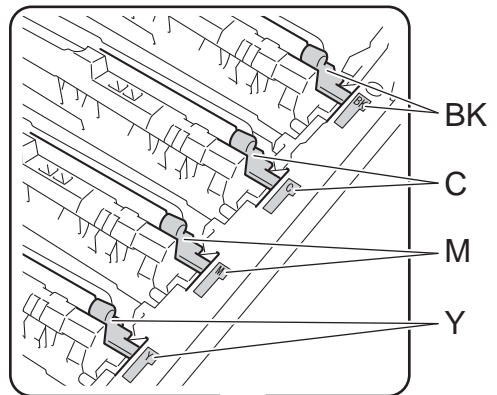
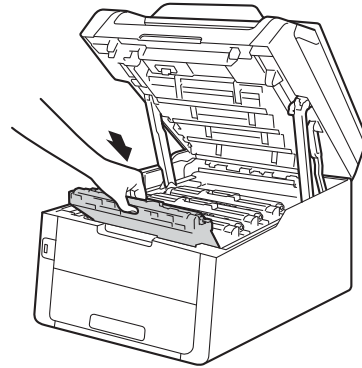

BK = Black, C = Cyan,  
M = Magenta, Y = Yellow

- 22 Close the top cover of the machine.
- 23 Turn on the machine and try a test print.

## Cleaning the paper pick-up rollers

---

Cleaning the paper pick-up roller periodically may prevent paper jams by ensuring the correct feeding of the paper.

If you have paper feed problems, clean the pick-up rollers as follows:

- 1 Press and hold down  to turn the machine off.
- 2 Pull the paper tray completely out of the machine.

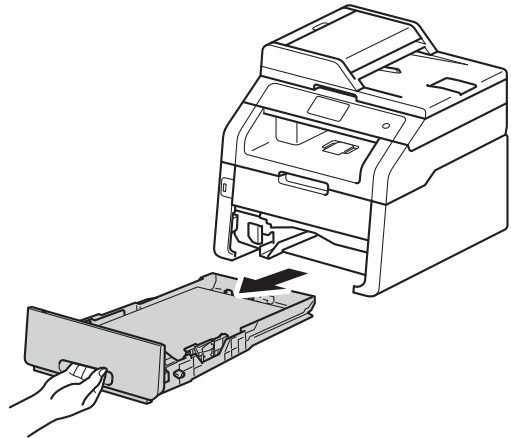

- 3 If paper is loaded in the paper tray, remove it.

- 4 Tightly wring out a lint-free cloth soaked in lukewarm water, and then wipe the separator pad (1) on the paper tray to remove dust.

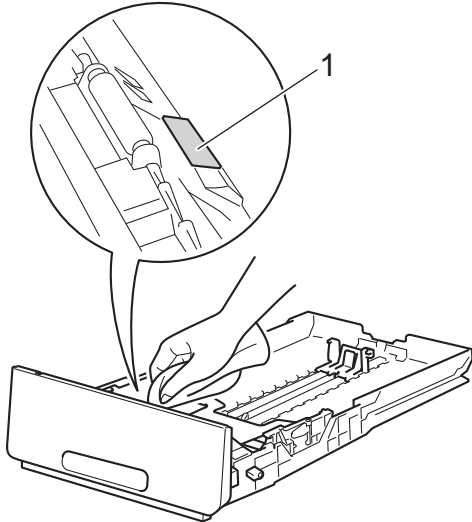

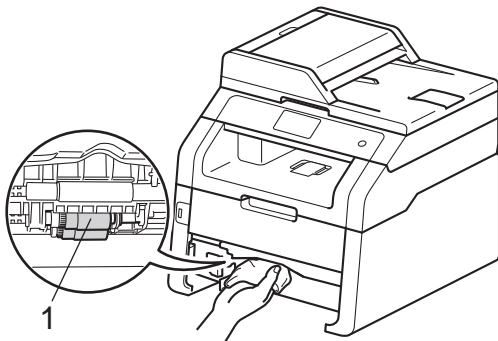

- 5 Wipe the two pick-up rollers (1) inside the machine to remove dust.





- 6 Put the paper tray back in the machine.
- 7 Reload the paper and put the paper tray firmly back in the machine.
- 8 Turn on the machine.

## Calibration

The output density for each colour may vary depending on the machine's environment, such as temperature and humidity. Calibration helps you to improve the colour density.

- 1 Press .
- 2 Press Calibration.
- 3 Press Calibrate.
- 4 Press Yes to confirm.
- 5 The machine will display Completed.
- 6 Press .

You can reset the calibration parameters back to the factory settings.

- 1 Press .
- 2 Press Calibration.
- 3 Press Reset.
- 4 Press Yes to confirm.
- 5 The machine will display Completed.
- 6 Press .

## NOTE

---

- If an error message is displayed, press **OK** and try again.



(For more information, see *Error and maintenance messages* on page 114.)

- If you are using the Windows® printer driver, the driver will get the calibration data automatically if both **Use Calibration Data** and **Get Device Data Automatically** are selected. The default settings are on (see Software User's Guide).
  - If you are using the Macintosh printer driver, you must perform the calibration using the Status Monitor. Turn on the Status Monitor, and then select **Color Calibration** from the **Control** menu (see Software User's Guide).
- 

## Auto Registration

---

If solid areas of colour or images have cyan, magenta or yellow fringes, you can use the auto-registration feature to correct the problem.



- 1 Press .
- 2 Press **Auto Regist..**
- 3 Press **Yes** to confirm.
- 4 The machine will display **Completed**.
- 5 Press .



## Frequency (Colour Correction)

---

You can set how often the colour correction (Colour Calibration and Auto Registration) occurs. The default setting is Normal. The colour correction process consumes some amount of the toner.

- 1 Press .
- 2 Press All Settings.
- 3 Swipe up or down, or press ▲ or ▼ to display Printer.
- 4 Press Printer.
- 5 Swipe up or down, or press ▲ or ▼ to display Frequency.
- 6 Press Frequency.
- 7 Press Normal, Low or Off.
- 8 Press .

# B

# Troubleshooting

If you think there is a problem with your machine, check each of the items below first and follow the troubleshooting tips.

You can correct most problems by yourself. If you need additional help, the Brother Solutions Center offers the latest FAQs and troubleshooting tips.

Visit us at <http://solutions.brother.com/>.

## Identifying your problem

First, check the following:

- The machine's power cord is connected correctly and the machine's power is on. If the machine does not turn on after connecting the power cord, see *Other difficulties* on page 143.
- All of the protective parts have been removed.
- Paper is inserted correctly in the paper tray.
- The interface cables are securely connected to the machine and the computer, or the wireless connection is set up on both the machine and your computer.

- Touchscreen Messages

(See *Error and maintenance messages* on page 114.)

If you did not solve your problem with the above checks, identify your problem and then go to the page suggested below.

Paper handling and Printing problems:

- *Printing difficulties* on page 135
- *Paper handling difficulties* on page 136
- *Printing received faxes* on page 137

Telephone and Fax problems:

- *Telephone line or connections* on page 137
- *Handling incoming calls* on page 140
- *Receiving Faxes* on page 138
- *Sending faxes* on page 139

Copying problems:

- *Copying difficulties* on page 140

Scanning problems:

- *Scanning difficulties* on page 141

Software and Network problems:



- *Software difficulties* on page 141
- *Network difficulties* on page 142

## Error and maintenance messages

As with any sophisticated office product, errors may occur and consumable items may have to be replaced. If this happens, your machine identifies the error or required routine maintenance and shows the appropriate message. The most common error and maintenance messages are shown in the table.

You can clear most errors and perform routine maintenance by yourself. If you need more help, the Brother Solutions Center offers the latest FAQs and troubleshooting tips:

Visit us at <http://solutions.brother.com/>.



Error Message	Cause	Action
2-sided Disabled	The back cover of the machine is not closed completely.	Close the back cover of the machine until it locks into the closed position.
Access Denied	The function you want to use is restricted by Secure Function Lock 2.0.	Contact your administrator to check your Secure Function Lock Settings.
Access Error	The device was removed from the USB direct interface while the data was processing.	Press  . Reinsert the device and try to print with Direct Print.
Calibration failed.	Calibration failed.	<p>Press <b>OK</b> and try it again.</p> <ul style="list-style-type: none"> <li>■ Press and hold down  to turn off the machine. Wait a few seconds, and then turn on the machine again.</li> <li>■ Perform the colour calibration again using the Touchscreen or the printer driver (see <i>Calibration</i> on page 109).</li> <li>■ Put in a new belt unit (see <i>Replacing the belt unit</i> on page 86).</li> <li>■ If the problem continues, contact Brother customer service or your local Brother dealer.</li> </ul>
Cartridge Error Put the Toner Cartridge back inX <sup>1</sup>	The toner cartridge is not installed correctly.	<p>Pull out the toner cartridge and drum unit assembly for the colour that is indicated on the Touchscreen. Remove the toner cartridge, and put it back into the drum unit again. Put the toner cartridge and drum unit assembly back in the machine.</p> <p>If the problem continues, contact Brother customer service or your local Brother dealer.</p>
<sup>1</sup> (x) shows the toner cartridge colour with the problem. (BK)=Black, (Y)=Yellow, (M)=Magenta, (C)=Cyan.		

Error Message	Cause	Action
Comm.Error	Poor telephone line quality caused a communication error.	Try sending the fax again or try connecting the machine to another telephone line. If the problem continues, contact the telephone company and ask them to check your telephone line.
Connection Failed	You tried to poll a fax machine that is not in Polled Waiting mode.	Check the other fax machine's polling setup.
Cooling Down Wait for a while	The temperature of the drum unit or toner cartridge is too hot. The machine will pause its current print job and go into cooling down mode. During the cooling down mode, you will hear the cooling fan running while the Touchscreen shows Cooling Down, and Wait for a while.	<p>Make sure you can hear the fan in the machine spinning and that the exhaust outlet is not blocked by something.</p> <p>If the fan is spinning, remove any obstacles that surround the exhaust outlet, and then leave the machine turned on but do not use it for several minutes.</p> <p>If the fan is not spinning, disconnect the machine from the power for several minutes, then reconnect it.</p>
Cover is Open.	The top cover is not completely closed.	Close the top cover of the machine.
	The fuser cover is not completely closed or paper was jammed in the back of the machine when you turned on the power.	<ul style="list-style-type: none"> <li>■ Close the fuser cover located inside the back cover of the machine.</li> <li>■ Make sure paper is not jammed behind the fuser cover at the back of the machine, then close the fuser cover and press Start (see <i>Paper is jammed at the back of the machine</i> on page 128).</li> </ul>
	The ADF cover is not completely closed.	Close the ADF cover of the machine.
	The ADF cover is open while loading a document.	Close the ADF cover of the machine, then press  .
Disconnected	The other person or other person's fax machine stopped the call.	Try to send or receive again.
Document Jam	The document was not inserted or fed correctly, or the document scanned from the ADF was too long.	See <i>Document is jammed in the top of the ADF unit</i> on page 124 or <i>Using the automatic document feeder (ADF)</i> on page 34.
Drum End SoonX <sup>1</sup>	The drum unit for the colour indicated on the Touchscreen is near the end of its life.	Order a new drum unit for the colour indicated on the Touchscreen before you get a Replace DrumX message.



<sup>1</sup> (x) shows the drum unit colour that is near the end of its life.  
(BK)=Black,  
(Y)=Yellow,  
(M)=Magenta,  
(C)=Cyan.



Error Message	Cause	Action
Drum !	The corona wires on the drum units must be cleaned.	Clean the corona wires on the drum units (see <i>Cleaning the corona wires</i> on page 99).
	The drum unit or the toner cartridge and drum unit assembly is not installed correctly.	Put the toner cartridge into the drum unit that is indicated on the Touchscreen. Then reinstall the toner cartridge and drum unit assembly into the machine.
Drum Stop	It is time to replace the drum unit.	Replace the drum unit for the colour indicated on the Touchscreen. (see <i>Replacing the drum units</i> on page 81).
Fuser Error	The temperature of the fuser unit does not rise to a specified temperature within the specified time.	Press and hold down  to turn the machine off, wait a few seconds, and then turn it on again. Leave the machine idle for 15 minutes with the power on.
	The fuser unit is too hot.	
Jam 2-Sided	The paper is jammed underneath the paper tray or the fuser unit.	See <i>Paper is jammed underneath the paper tray</i> on page 133.
Jam Inside	The paper is jammed inside the machine.	See <i>Paper is jammed inside the machine</i> on page 130.
Jam Manual Feed	The paper is jammed in the manual feed slot of the machine.	See <i>Paper is jammed in the manual feed slot</i> on page 126.
Jam Rear	The paper is jammed in the back of the machine.	See <i>Paper is jammed at the back of the machine</i> on page 128.
Jam Tray	The paper is jammed in the paper tray of the machine.	See <i>Paper is jammed in the paper tray</i> on page 126.
Limit Exceeded	The number of pages you are allowed to print has been exceeded. The print job will be cancelled.	Contact your administrator to check your Secure Function Lock Settings.
Log Access Error	The machine could not access the print log file in the server.	Contact your administrator to check the Store Print Log to Network settings.  For more information, see Network User's Guide: <i>Store Print Log to Network</i>
Low Temperature	The room temperature is too low for the machine to operate.	Increase the room temperature to allow the machine to operate.
Manual Feed	<b>Manual</b> was selected as the paper source when there was no paper in the manual feed slot.	Place paper in the manual feed slot (see <i>Loading paper in the manual feed slot</i> on page 23).
No Belt Unit	The belt unit is not installed correctly.	Reinstall the belt unit (see <i>Replacing the belt unit</i> on page 86).
No HUB Support	A USB hub device is connected to the USB direct interface.	Disconnect the USB hub device from the USB direct interface.

Error Message	Cause	Action
No Permission	Printing colour documents is restricted by Secure Function Lock 2.0. The print job will be cancelled.	Contact your administrator to check your Secure Function Lock Settings.
No Paper	The machine is out of paper in the paper tray, or paper is not correctly loaded in the paper tray.	Do one of the following: <ul style="list-style-type: none"> <li>■ Refill paper in the paper tray. Make sure the paper guides are set to the correct size.</li> <li>■ Remove the paper and load it again. Make sure the paper guides are set to the correct size.</li> </ul>
No Response/Busy	The number you dialled does not answer or is busy.	Verify the number and try again.
No Toner	The toner cartridge or the toner cartridge and drum unit assembly is not installed correctly.	Remove the toner cartridge and drum unit assembly for the colour indicated on the Touchscreen. Remove the toner cartridge from the drum unit, and reinstall the toner cartridge back into the drum unit. Reinstall the toner cartridge and drum unit assembly back in the machine. If the problem continues, replace the toner cartridge (see <i>Replacing the toner cartridges</i> on page 73).
No Tray	The paper tray is not installed or not installed correctly.	Reinstall the paper tray.
No Waste Toner	The waste toner box is not installed correctly.	Reinstall the Waste Toner Box (see <i>Replacing the waste toner box</i> on page 90).

Error Message	Cause	Action
Out of Memory	The machine's memory is full.	<p><b>Fax sending or copy operation in progress</b></p> <p>Do one of the following:</p> <ul style="list-style-type: none"> <li>■ Press <b>Send Now</b>, <b>Partial Print</b> or <b>Quit</b> to send or copy the scanned pages.</li> <li>■ Press  and wait until the other operations in progress finish, and then try again.</li> <li>■ Clear the faxes from the memory.</li> </ul> <p>Print the faxes that are stored in the memory to restore the memory to 100%. Then turn off Fax Storage to avoid storing more faxes in the memory (see <i>Advanced User's Guide: Printing a fax from the memory and Fax Storage</i>).</p> <p><b>Print operation in process</b></p> <p>Do one of the following:</p> <ul style="list-style-type: none"> <li>■ Reduce the print resolution. (See <i>Software User's Guide</i>.)</li> <li>■ Clear the faxes from the memory (see the above explanation).</li> </ul>
Out of Memory Secure Print Data is full. Press Stop Key and delete the previously stored data.	The machine's memory is full.	Press  and delete the previously stored secure print data.
Print Unable XX (XX = Error Code)	The machine has a mechanical problem.	<p>Do one of the following:</p> <ul style="list-style-type: none"> <li>■ Press and hold down  to turn the machine off, wait a few minutes, and then turn it on again (see <i>Transferring your faxes or Fax Journal report</i> on page 122).</li> <li>■ If the problem continues, contact Brother customer service for support.</li> </ul>



Error Message	Cause	Action
Registration failed.	Registration failed.	<p>Press <b>OK</b> and try again.</p> <ul style="list-style-type: none"> <li>■ Press and hold down  to turn off the machine.</li> </ul> <p>Wait a few seconds, then turn it on again.</p> <p>Perform the auto colour registration using the Touchscreen (see <i>Auto Registration</i> on page 110).</p> <ul style="list-style-type: none"> <li>■ Put in a new belt unit (see <i>Replacing the belt unit</i> on page 86).</li> <li>■ If the problem continues, contact Brother customer service.</li> </ul>
Rename the File	There is already a file on the USB Flash memory drive with the same name as the file you are trying to save.	Change the file name of the file on the USB Flash memory drive or the file you are trying to save.
Replace Belt	It is time to replace the belt unit.	Replace the belt unit (see <i>Replacing the belt unit</i> on page 86).
Replace DrumX <sup>1</sup>	It is time to replace the drum unit.	Replace the drum unit for the colour indicated on the Touchscreen (see <i>Replacing the drum units</i> on page 81).
<sup>1</sup> (x) shows drum unit colour that must be replaced. BK=Black, C=Cyan, M=Magenta, Y=Yellow.	The drum unit counter was not reset when a new drum was installed.	Reset the drum unit counter. (see <i>Replacing the drum units</i> on page 81).
Replace Fuser	It is time to replace the fuser unit.	Contact Brother customer service or a Brother Authorized Service Center to replace the fuser unit.
Replace PF kit	It is time to replace the paper feeding kit.	Contact Brother customer service or a Brother Authorized Service Center to replace the PF Kit.
Replace Toner <sup>1</sup>	The toner cartridge is at the end of its life. The machine will stop all print operations.	Replace the toner cartridge for the colour indicated on the Touchscreen (see <i>Replacing the toner cartridges</i> on page 73).
<sup>1</sup> The Touchscreen shows the toner cartridge colour that you must replace. BK=Black, C=Cyan, M=Magenta, Y=Yellow	While memory is available, faxes will be stored in the memory.	
Replace WT Box	It is time to replace the waste toner box.	Replace the waste toner box (see <i>Replacing the waste toner box</i> on page 90).
Scan Unable	Document is too long for 2-sided scanning.	Press  . Use the appropriate size of paper for 2-sided scanning (see <i>Print media</i> on page 209).

Error Message	Cause	Action
Scan Unable XX (XX = Error Code)	The machine has a mechanical problem.	<ul style="list-style-type: none"> <li>■ Press and hold down  to turn the machine off, and then turn it on again (see <i>Transferring your faxes or Fax Journal report</i> on page 122).</li> <li>■ If the problem continues, contact Brother customer service for support.</li> </ul>
Short paper	The length of the paper in the tray is too short for the machine to deliver it to the Face down output tray.	Open the back cover (face-up output tray) to let the printed page exit onto the face up output tray. Remove the printed pages and then press <i>Start</i> .
Size Error 2-sided	The paper size defined in the printer driver and the Touchscreen menu is not available for automatic 2-sided printing.	Press  . Choose a paper size that is supported by 2-sided printing. The paper size you can use for automatic 2-sided printing is A4.
	The paper in the tray is not the correct size and is not available for automatic 2-sided printing.	Load the correct size of paper in the tray and set the size of paper for the tray (see <i>Paper Size</i> on page 28). The paper size you can use for automatic 2-sided printing is A4.
Size mismatch	The paper in the tray is not the correct size.	Load the correct size of paper in the tray and set the size of paper to the tray (see <i>Paper Size</i> on page 28).
Small paper	The paper size specified in the printer driver is too small for the machine to deliver it to the Face-down output tray.	Open the back cover (back output tray) to let the printed paper out on the back output tray and then press <i>Start</i> .
Toner Error	One or more toner cartridges are not installed correctly.	Pull out the drum units. Remove all of the toner cartridges, and then put them back into the drum units.
Toner Low	If the Touchscreen shows <i>Toner Low</i> you can still print; however, the machine is telling you that the toner cartridge is near the end of its life.	Order a new toner cartridge for the colour that is indicated on the Touchscreen now so a replacement toner cartridge will be available when the Touchscreen shows <i>Replace Toner</i> .
Too Many Files	There are too many files stored on the USB Flash memory drive.	Reduce the number of files stored on the USB Flash memory drive.
Touchscreen Initialisation Failed	The Touchscreen was pressed before the power on initialization was completed.	Make sure nothing is touching or resting on the Touchscreen.
	Debris may be stuck between the lower part of the Touchscreen and its frame.	Insert a piece of stiff paper between the lower part of the Touchscreen and its frame and slide it back and forth to push out the debris.

Error Message	Cause	Action
Unusable Device Remove the Device. Turn the power off and back on again.	A defective USB device or a high power consumption USB device has been connected to the USB direct interface.	Unplug the device from the USB direct interface. Press and hold down  to turn the machine off, and then turn it on again.
Unusable Device	A USB device or USB Flash memory drive that is not supported/is encrypted has been connected to the USB direct interface.	Unplug the device from the USB direct interface (see the specifications for supported USB Flash memory drives in <i>Printing data from a USB Flash memory drive or digital camera supporting mass storage (For MFC-9340CDW)</i> on page 59).
USB Access Error	The device was removed from USB direct interface while accessing the USB device.	Press <b>Close</b> . Reinsert the device and try to store the scanned data to the device.
USB Write-protected	The protect switch of the USB Flash memory drive is on.	Turn off the protect switch of the USB Flash memory drive.
WT Box End Soon	The waste toner box is near the end of its life.	Buy a new waste toner box before you get a <b>Replace WT Box</b> message.

## Transferring your faxes or Fax Journal report

---

If the Touchscreen shows:

- Print Unable XX
- Scan Unable XX

We recommend transferring your faxes to another fax machine or to your computer (see *Transferring faxes to another fax machine* on page 122 or *Transferring faxes to your computer* on page 123).

You can also transfer the Fax Journal report to see if there are any faxes you must transfer (see *Transferring the Fax Journal report to another fax machine* on page 123).

### NOTE



---

If there is an error message on the Touchscreen after the faxes have been transferred, disconnect the machine from the power source for several minutes, and then reconnect it.

---

## Transferring faxes to another fax machine

If you have not set up your Station ID, you cannot enter fax transfer mode (see Quick Setup Guide: *Enter personal information (Station ID)*).



- 1 Press  to interrupt the error temporarily.
- 2 Press .
- 3 Press All Settings.
- 4 Swipe up or down, or press ▲ or ▼ to display Service.
- 5 Press Service.
- 6 Press Data Transfer.
- 7 Press Fax Transfer.
- 8 Do one of the following:
  - If the Touchscreen shows No Data, there are no faxes left in the machine's memory. Press Close.
  - Enter the fax number to which faxes will be forwarded.
- 9 Press Fax Start.

## Transferring faxes to your computer

You can transfer the faxes from your machine's memory to your computer.



- 1 Press  to interrupt the error temporarily.
- 2 Make sure you have installed **MFL-Pro Suite** and then turn on **PC-Fax Receiving** on the computer. Follow the instructions for the operating system you are using.
  - (Windows<sup>®</sup> XP, Windows Vista<sup>®</sup> and Windows<sup>®</sup> 7)
 

From the  (**Start**) menu, select **All Programs > Brother > MFC-XXXX > PC-FAX Receiving > Receive**. (XXXX is your model name.)
  - (Windows<sup>®</sup> 8)
 

Click  (**Brother Utilities**), and then click the drop-down list and select your model name (if not already selected). Click **PC-FAX Receive** in the left navigation bar, and then click **Receive**.
- 3 Make sure you have set **PC Fax Receive** on the machine (see *PC-Fax Receive (For Windows<sup>®</sup> only)* on page 46). If faxes are in the machine's memory when you set up PC-Fax Receive, the Touchscreen will ask if you want to transfer the faxes to your computer.
- 4 Do one of the following:
  - To transfer all faxes to your computer, press **Yes**. If Fax Preview is set to Off, you will be asked if you want to print backup copies.
  - To exit and leave the faxes in the memory, press **No**.
- 5 Press .

## Transferring the Fax Journal report to another fax machine

If you have not set up your Station ID, you cannot enter fax transfer mode (see Quick Setup Guide: *Enter personal information (Station ID)*).

- 1 Press  to interrupt the error temporarily.
- 2 Press .
- 3 Press **All Settings**.
- 4 Swipe up or down, or press **▲** or **▼** to display **Service**.
- 5 Press **Service**.
- 6 Press **Data Transfer**.
- 7 Press **Report Transfer**.
- 8 Enter the fax number to which the Fax Journal report will be forwarded.
- 9 Press **Fax Start**.

## Document Jams

### Document is jammed in the top of the ADF unit

---

- 1 Remove any paper from the ADF that is not jammed.
- 2 Open the ADF cover.
- 3 Pull the jammed document out to the left.

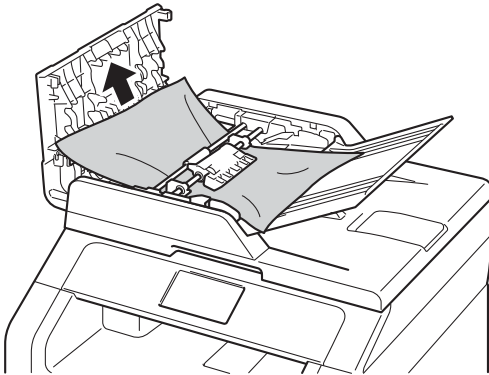

If the document rips or tears, be sure you remove all small paper scraps to prevent future jams.

- 4 Close the ADF cover.
- 5 Press .

### Document is jammed under the document cover

---

- 1 Remove any paper from the ADF that is not jammed.
- 2 Lift the document cover.
- 3 Pull the jammed document out to the right.

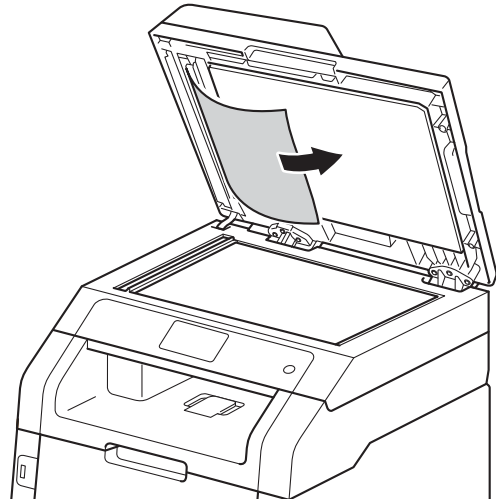



If the document rips or tears, be sure you remove all small paper scraps to prevent future jams.

- 4 Close the document cover.
- 5 Press .

## Removing small documents jammed in the ADF

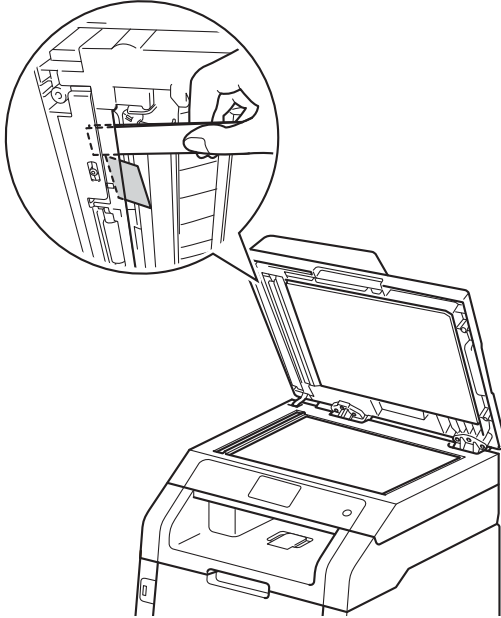
- 1 Lift the document cover.
- 2 Insert a piece of stiff paper, such as cardstock, into the ADF to push any small paper scraps through.



- 3 Close the document cover.
- 4 Press .

## Document is jammed at the output tray

- 1 Remove any paper from the ADF that is not jammed.
- 2 Pull the jammed document out to the right.

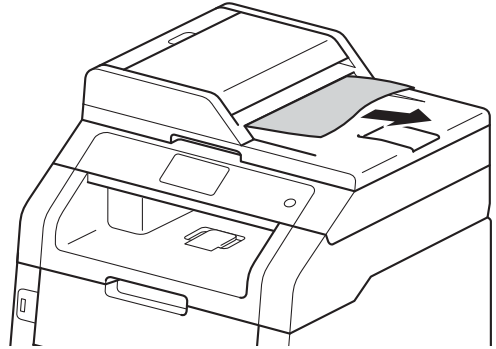

- 3 Press .

## Paper Jams

Always remove the remaining paper from the paper tray and straighten the stack when you are adding new paper. This helps prevent multiple sheets of paper from feeding through the machine at one time and prevents paper jams.

### Paper is jammed in the manual feed slot

If the Touchscreen shows **Jam Manual Feed**, follow these steps:

- 1 Remove any paper that is jammed in and around the manual feed slot.

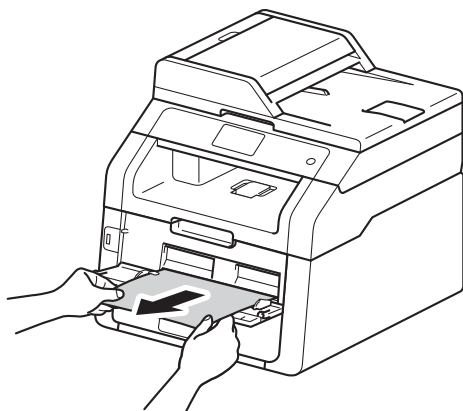

- 2 Press **Start** to resume printing.

### Paper is jammed in the paper tray

If the Touchscreen shows **Jam Tray**, follow these steps:

- 1 Pull the paper tray completely out of the machine.

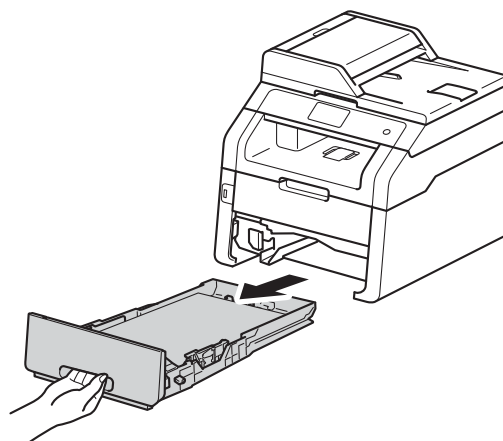

- 2 Use both hands to slowly pull out the jammed paper.

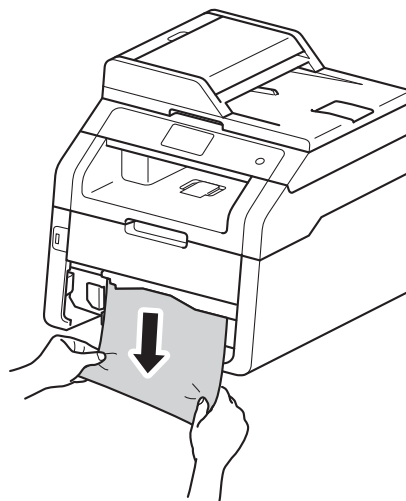

#### NOTE

Pulling the jammed paper downward allows you to remove the paper more easily.



- 3 Make sure the paper is below the maximum paper mark (▼▼▼) in the paper tray. While pressing the green paper-guide release lever, slide the paper guides to fit the paper size. Make sure the guides are firmly in the slots.
- 4 Put the paper tray firmly back in the machine.

## Paper is jammed at the output paper tray

When the paper is jammed at the output paper tray, follow the these steps:

- 1 Use both hands to open the scanner.

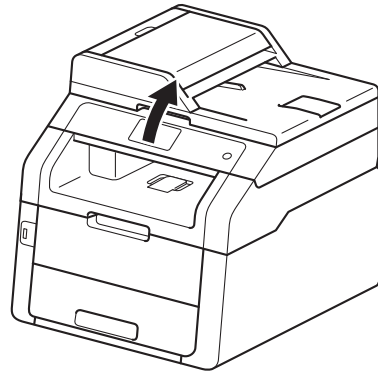

### NOTE

When the top cover is open, you cannot open the scanner.

- 2 Remove the paper.

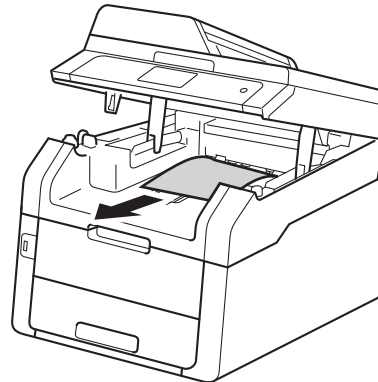

- 3 Push the scanner down with both hands to close it.

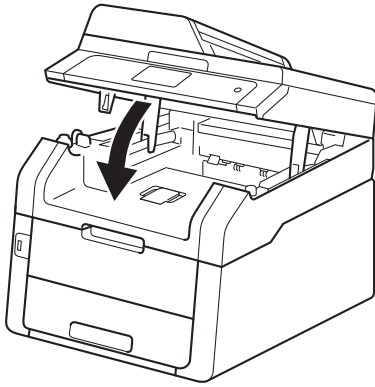

## Paper is jammed at the back of the machine

If the Touchscreen shows *Jam Rear*, follow these steps:

- 1 Leave the machine turned on for 10 minutes for the internal fan to cool the extremely hot parts inside the machine.
- 2 Open the back cover.

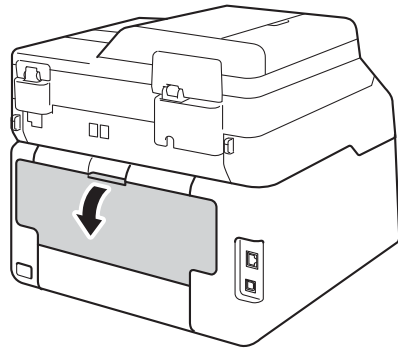

### WARNING

#### HOT SURFACE

After you have just used the machine, some internal parts of the machine will be extremely hot. Wait for the machine to cool down before you touch the internal parts.

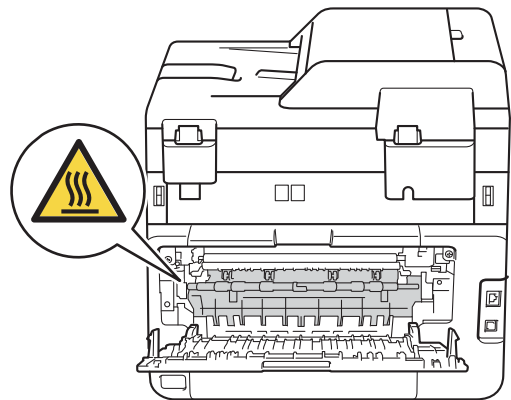

- 3 Pull the green tabs at the left and right sides down to release the fuser cover (1).

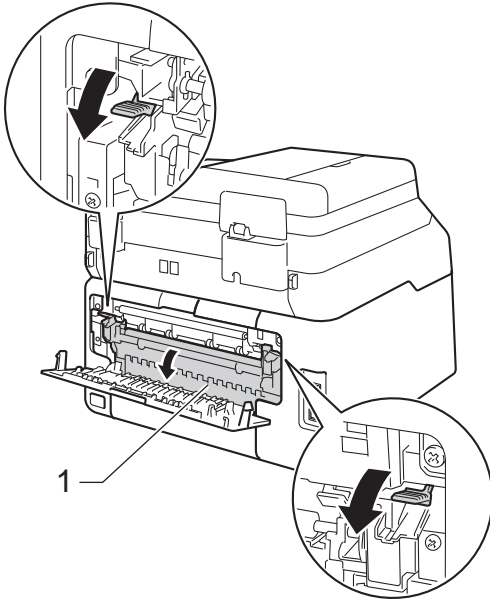

- 5 Close the fuser cover (1). Make sure the green tabs at the left and right sides lock into place.

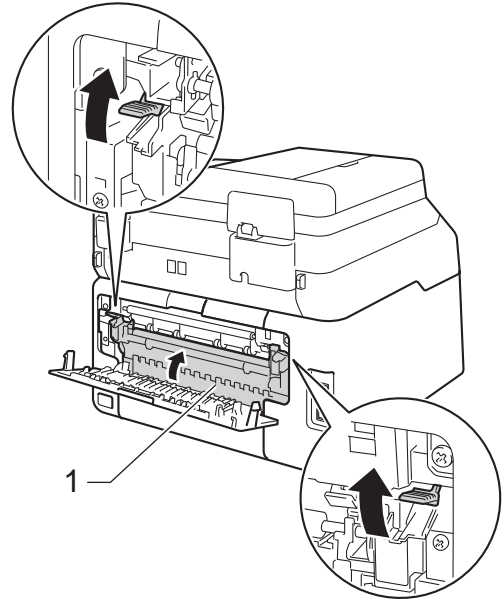

- 4 Use both hands to gently pull the jammed paper out of the fuser unit.

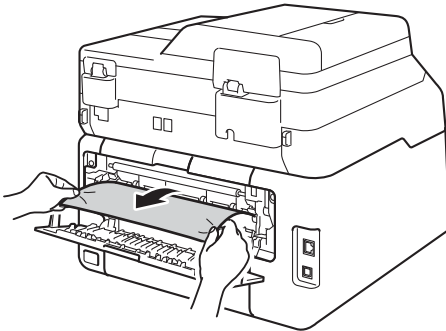

- 6 Close the back cover until it locks in the closed position.

## Paper is jammed inside the machine

If the Touchscreen shows **Jam Inside**, follow these steps:

- 1 Leave the machine turned on for 10 minutes for the internal fan to cool the extremely hot parts inside the machine.
- 2 Open the top cover until it locks in the open position.

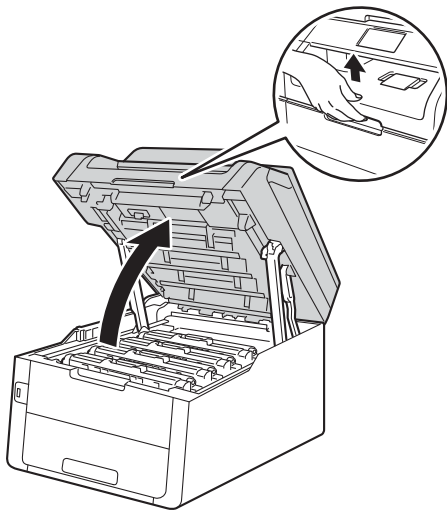

- 3 Remove all of the toner cartridge and drum unit assemblies.

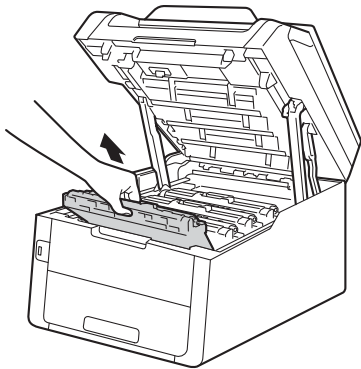

## WARNING

### HOT SURFACE

After you have just used the machine, some internal parts of the machine will be extremely hot. Wait for the machine to cool down before you touch the internal parts.

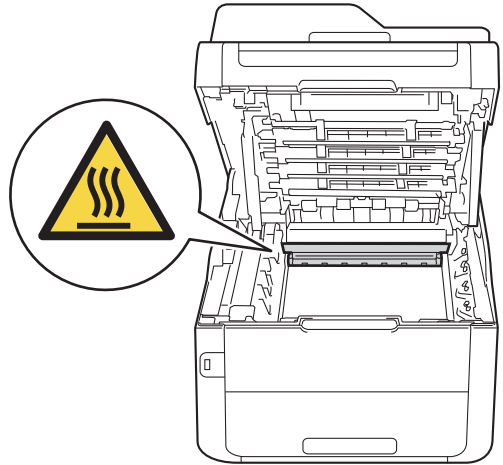

## IMPORTANT

- We recommend that you place the toner cartridge and drum unit assemblies on a clean, flat surface with disposable paper underneath them in case you accidentally spill or scatter toner.
- To prevent damage to the machine from static electricity, DO NOT touch the electrodes shown in the illustration.

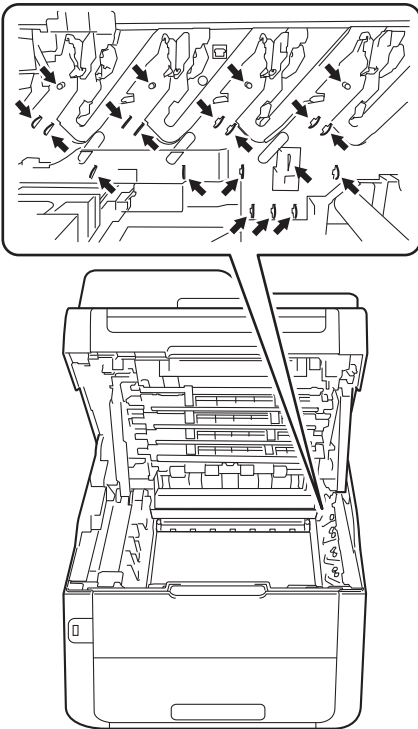

- 4 Pull out the jammed paper slowly.

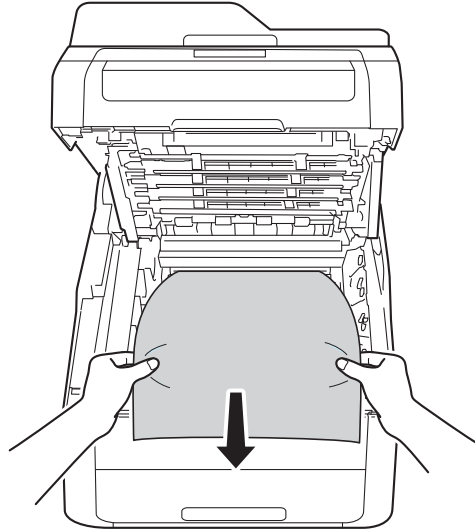

- 5 Slide each toner cartridge and drum unit assembly into the machine, making sure you match the toner cartridge colours to the same colour labels on the machine.

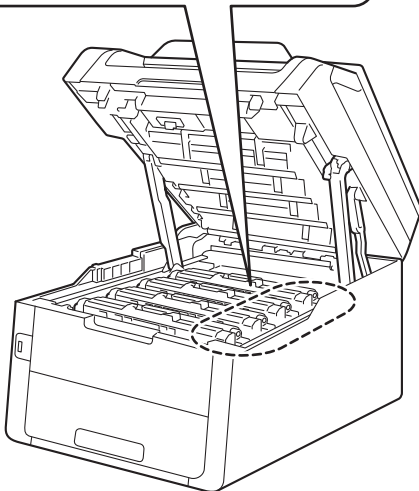
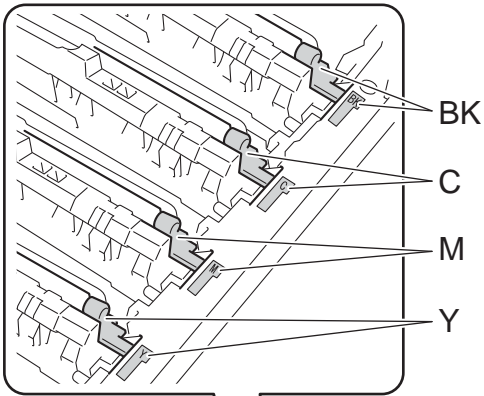
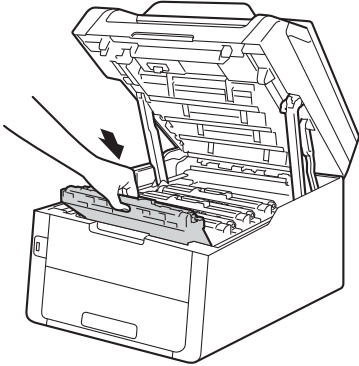

BK = Black, C = Cyan,  
M = Magenta, Y = Yellow

- 6 Close the top cover of the machine.

**NOTE**

If you turn off the machine during *Jam Inside* is on the Touchscreen, the machine will print incomplete data from your computer when it is turned on. Before you turn on the machine, delete the job from your computer's print spooler.

## Paper is jammed underneath the paper tray

If the Touchscreen shows **Jam 2-sided**, follow these steps:

- 1 Leave the machine turned on for 10 minutes for the internal fan to cool the extremely hot parts inside the machine.
- 2 Pull the paper tray completely out of the machine.

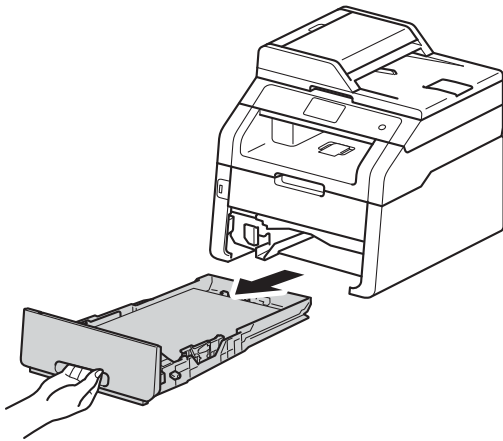

- 3 Make sure the jammed paper does not remain inside the machine.

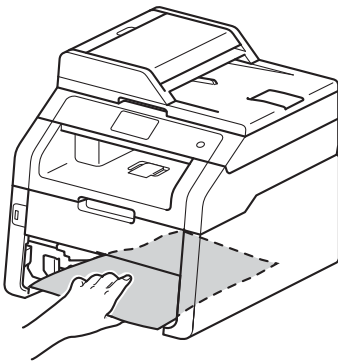

- 4 If paper is not caught inside the machine, check underneath the paper tray.

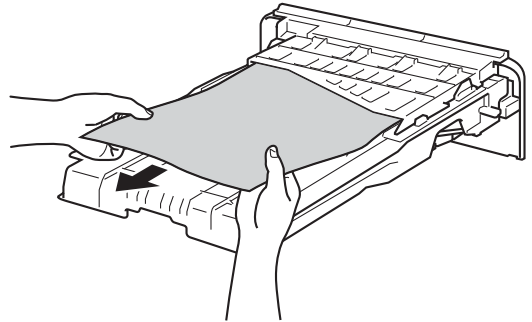

- 5 If the paper is not caught in the paper tray, open the back cover.

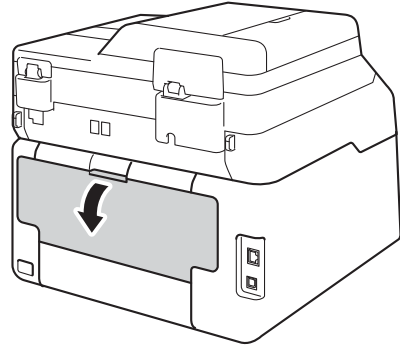

## WARNING

### HOT SURFACE

After you have just used the machine, some internal parts of the machine will be extremely hot. Wait for the machine to cool down before you touch the internal parts.

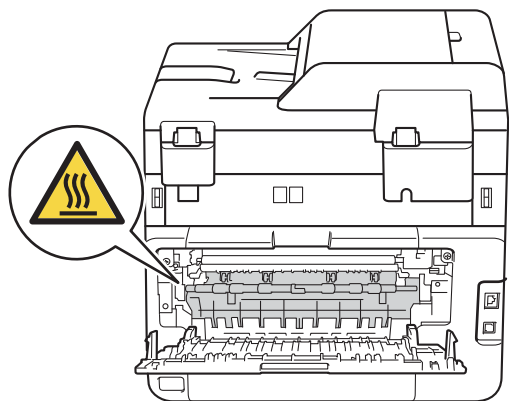

- 6 Use both hands to gently pull the jammed paper out of the back of the machine.

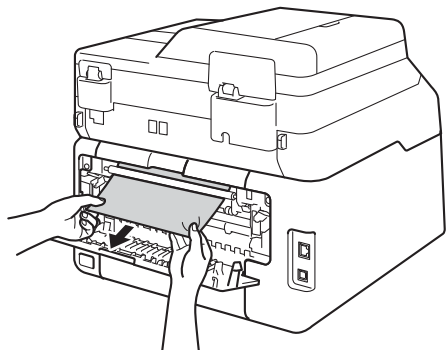

- 7 Close the back cover until it locks in the closed position.
- 8 Put the paper tray firmly back in the machine.





# If you are having difficulty with your machine

## IMPORTANT

- For technical help, you must call the country where you bought the machine. Calls must be made from within that country.
- If you think there is a problem with your machine, check the chart below and follow the troubleshooting tips. You can correct most problems by yourself.
- If you need additional help, the Brother Solutions Center offers the latest FAQs and troubleshooting tips.

Visit us at <http://solutions.brother.com/>.

## Printing difficulties

Difficulties	Suggestions
No printout.	<p>Check that the correct printer driver has been installed and selected.</p> <p>Check to see if the Touchscreen is showing an error message (see <i>Error and maintenance messages</i> on page 114).</p> <p>Check the machine is online: (Windows® 7 and Windows Server® 2008 R2) Click the  (<b>Start</b>) button &gt; <b>Devices and Printers</b>. Right-click <b>Brother MFC-XXXX Printer</b> and click <b>See what's printing</b>. Click <b>Printer</b> in the menu bar. Make sure <b>Use Printer Offline</b> is cleared. (Windows Vista® and Windows Server® 2008) Click the  (<b>Start</b>) button &gt; <b>Control Panel</b> &gt; <b>Hardware and Sound</b> &gt; <b>Printers</b>. Right-click <b>Brother MFC-XXXX Printer</b>. Make sure <b>Use Printer Online</b> is not listed. If it is listed, click this option to set the driver Online. (Windows® XP and Windows Server® 2003) Click the <b>Start</b> button &gt; <b>Printers and Faxes</b>. Right-click <b>Brother MFC-XXXX Printer</b>. Make sure <b>Use Printer Online</b> is not listed. If it is listed, click this option to set the driver Online. (Windows® 8 and Windows Server® 2012) Move your mouse to the lower right corner of your desktop. When the menu bar appears, click <b>Settings</b> &gt; <b>Control Panel</b>. In the <b>Hardware and Sound</b> (Hardware) group, click <b>View devices and printers</b>. Right-click the <b>Brother MFC-XXXX Printer</b> &gt; <b>See what's printing</b>. If printer driver options appear, select your printer driver. Click <b>Printer</b> in the menu bar and make sure that <b>Use Printer Offline</b> is not selected.</p> <p>Contact your administrator to check your Secure Function Lock settings.</p>
The machine is not printing or has stopped printing.	<p>Press .</p> <p>The machine will cancel the print job and clear it from the memory. The printout may be incomplete.</p>
The headers or footers appear when the document displays on the screen but they are not on the printed page.	<p>There is an unprintable area on the top and bottom of the page. Adjust the top and bottom margins in your document to allow for this (see <i>Unscannable and unprintable areas</i> on page 27).</p>

## Printing difficulties (continued)

Difficulties	Suggestions
The machine prints unexpectedly or it prints garbage.	Press  to cancel print jobs.
	Check the settings in your application to make sure they are set up to work with your machine.
The machine prints the first couple of pages correctly, then some pages have missing text.	Check the settings in your application to make sure they are set up to work with your machine.
	Your computer is not recognising the full signal of the machine's input buffer. Make sure you connected the interface cable correctly (see Quick Setup Guide).
The machine does not print on both sides of the paper even though the printer driver setting is 2-sided.	Check the paper size setting in the printer driver. You must choose A4 (60 to 105 g/m <sup>2</sup> ).
The machine does not display the USB menu when a USB flash memory drive is connected to the USB direct interface.	When the machine is in Deep Sleep mode, the machine does not wake up even if you connect a USB flash memory drive to the USB direct interface. Press the Touchscreen to wake up the machine.
Cannot perform 'Page Layout' printing.	Check that the paper size setting in the application and in the printer driver are the same.
Print speed is too slow.	Try changing the printer driver setting. The highest resolution needs longer data processing, sending and printing time.
The machine does not print from Adobe® Illustrator®.	Try to reduce the print resolution (see Software User's Guide).
Poor print quality	See <i>Improving the print quality</i> on page 145.

## Paper handling difficulties

Difficulties	Suggestions
The machine does not feed paper.	If the Touchscreen shows a Paper Jam message and you still have a problem, see <i>Error and maintenance messages</i> on page 114.
	If the paper tray is empty, load a new stack of paper into the paper tray.
	If there is paper in the paper tray, make sure it is straight. If the paper is curled, straighten it. Sometimes it is helpful to remove the paper, turn the stack over and put it back in the paper tray.
	Reduce the amount of paper in the paper tray, and then try again.
	Make sure <b>Manual</b> is not selected for <b>Paper Source</b> in the printer driver.
	Clean the paper pick-up rollers (see <i>Cleaning the paper pick-up rollers</i> on page 108).
The machine does not feed paper from the Manual feed slot.	Use both hands to push one sheet of paper firmly into the manual feed slot until the top edge of the paper presses against the paper feed rollers. Continue pressing the paper against the rollers until the machine grabs the paper and pulls it in further.
	Put only one sheet of paper in the manual feed slot.
	Make sure <b>Manual</b> is selected for <b>Paper Source</b> in the printer driver.
How do I print on envelopes?	Load one envelope at a time in the manual feed slot. Your application must be set to print the envelope size you are using. This is usually done in the Page Setup or Document Setup menu of your application (see your application's manual for more information).

## Printing received faxes

Difficulties	Suggestions
<ul style="list-style-type: none"> <li>■ Condensed print</li> <li>■ Horizontal streaks</li> <li>■ Top and bottom sentences are cut off</li> <li>■ Missing lines</li> </ul>	Usually this is caused by a poor telephone connection. Make a copy; if your copy looks good, you probably had a bad connection, with static or interference on the telephone line. Ask the other party to send the fax again.
Vertical black lines when receiving	<p>The corona wires for printing may be dirty. Clean the corona wires on the drum units (see <i>Cleaning the corona wires</i> on page 99).</p> <p>The sender's scanner may be dirty. Ask the sender to make a copy to see if the problem is with the sending machine. Try receiving from another fax machine.</p>
Received faxes appear as split or blank pages.	<p>Left and right margins are cut off or a single page is printed on two pages (see <i>Paper Size</i> on page 28).</p> <p>Turn on Auto Reduction (see <i>Advanced User's Guide: Printing a reduced incoming fax</i>).</p>

## Telephone line or connections

Difficulties	Suggestions
Dialling does not work. (No dial tone)	Check all line cord connections. Make sure the telephone line cord is plugged directly into the telephone wall socket and the LINE socket of the machine.
	Change <b>Tone/Pulse</b> setting (see <i>Quick Setup Guide</i> ).
	If an external phone is connected to the machine, send a manual fax by pressing <b>Hook</b> and dialling the number. Wait to hear the fax receiving tones before pressing <b>Fax Start</b> .
	If there is no dial tone, connect a known working telephone and telephone line cord directly into your master telephone wall socket. Then lift the external telephone's handset and listen for a dial tone. If there is still no dial tone, ask your telephone company to check the line and wall socket.
The machine does not answer when called.	<p>Make sure the machine is in the correct receive mode for your setup (see <i>Receive Mode settings</i> on page 41).</p> <p>Check for a dial tone. If possible, call your machine to hear it answer. If there is still no answer, check the telephone line cord connection. If you do not hear ringing when you call your machine, ask your telephone company to check the line.</p>

## Receiving Faxes

Difficulties	Suggestions
<p>Cannot receive a fax.</p>	<p>Make sure your machine has a dial tone by pressing <b>Hook</b>. If you hear static or interference on your fax line, contact your local telephone company.</p>
	<p>Check all line cord connections. Make sure the telephone line cord is directly plugged into the telephone wall socket and the <b>LINE</b> socket of the machine. If you subscribe to DSL or VoIP services, contact your service provider for connection instructions.</p>
	<p>Make sure the machine is in the correct <b>Receive Mode</b>. This is determined by the external devices and telephone subscriber services you have on the same line as the Brother machine (see <i>Receive Mode settings</i> on page 41).</p> <ul style="list-style-type: none"> <li>■ If you have a dedicated fax line and want your Brother machine to automatically answer all incoming faxes, you should select <b>Fax Auto</b> mode.</li> <li>■ If your Brother machine shares a line with an external answering machine, you should select the <b>External TAD</b> mode. In <b>External TAD</b> mode, your Brother machine will automatically receive incoming faxes and voice callers will be able to leave a message on your answering machine.</li> <li>■ If your Brother machine shares a line with other telephones and you want it to automatically answer all incoming faxes, you should select the <b>Fax/Tel</b> mode. In <b>Fax/Tel</b> mode, your Brother machine will automatically receive faxes and produce a fast double-ring to alert you to answer voice calls.</li> <li>■ If you do not want your Brother machine to automatically answer any incoming faxes, you should select the <b>Manual</b> mode. In <b>Manual</b> mode, you must answer every incoming call and activate the machine to receive faxes.</li> </ul>
	<p>Another device or service at your location may be answering the call before your Brother machine answers. To test this, lower the ring delay setting:</p> <ul style="list-style-type: none"> <li>■ If the answer mode is set to <b>Fax Auto</b> or <b>Fax/Tel</b>, reduce the ring delay to 1 ring (see <i>Ring Delay</i> on page 41).</li> <li>■ If the answer mode is set to <b>External TAD</b>, reduce the number of rings programmed on your answering machine to 2.</li> <li>■ If the answer mode is set to <b>Manual</b>, <b>DO NOT</b> adjust the ring delay setting.</li> </ul>
	<p>Have someone send you a test fax:</p> <ul style="list-style-type: none"> <li>■ If you received the test fax successfully, your machine is operating correctly. Remember to reset your ring delay or answering machine setting back to your original setting. If receiving problems recur after resetting the ring delay, then a person, device, or subscriber service is answering the fax call before the machine has a chance to answer.</li> <li>■ If you were not able to receive the fax, then another device or subscriber service may be interfering with your fax reception or there may be a problem with your fax line.</li> </ul>

## Receiving Faxes (continued)

Difficulties	Suggestions
Cannot receive a fax. (continued)	<p>If you are using a telephone answering machine (External TAD mode) on the same line as the Brother machine, make sure your answering machine is set up correctly (see <i>Connecting an external TAD</i> on page 48).</p> <ol style="list-style-type: none"> <li>1 Connect the external TAD as shown in the illustration, see page 48.</li> <li>2 Set your answering machine to answer in one or two rings.</li> <li>3 Record the outgoing message on your answering machine.                             <ul style="list-style-type: none"> <li>■ Record five seconds of silence at the beginning of your outgoing message.</li> <li>■ Limit your speaking to 20 seconds.</li> <li>■ End your outgoing message with your Remote Activation Code for people sending manual faxes. For example: "After the beep, leave a message or press *51 and Start to send a fax."</li> </ul> </li> <li>4 Set your answering machine to answer calls.</li> <li>5 Set your Brother machine's Receive Mode to External TAD (see <i>Receive Mode settings</i> on page 41).</li> </ol>
	<p>Make sure your Brother machine's Fax Detect feature is turned On. Fax Detect is a feature that allows you to receive a fax even if you have answered the call on an external or extension telephone (see <i>Fax Detect</i> on page 42).</p>
	<p>If you often get transmission errors due to possible interference on the telephone line, try changing the Compatibility setting to Basic (for VoIP) (see <i>Telephone line interference / VoIP</i> on page 144).</p>
	<p>Contact your administrator to check your Secure Function Lock Settings.</p>

## Sending faxes

Difficulties	Suggestions
Cannot send a fax.	<p>Check all line cord connections. Make sure the telephone line cord is plugged directly into the telephone wall socket and the LINE socket of the machine.</p>
	<p>Make sure you pressed Fax and the machine is in Fax mode (see <i>How to send a fax</i> on page 36).</p>
	<p>Print the Transmission Verification Report and check for an error (see <i>Advanced User's Guide: Reports</i>).</p>
	<p>Contact your administrator to check your Secure Function Lock Settings.</p>
Poor sending quality.	<p>Ask the other party to check that the receiving machine has paper.</p>
	<p>Try changing your resolution to Fine or S.Fine. Make a copy to check your machine's scanner operation. If the copy quality is not good, clean the scanner (see <i>Cleaning the scanner glass</i> on page 98).</p>

## Sending faxes (continued)

Difficulties	Suggestions
Transmission Verification Report says RESULT:ERROR.	<p>There is probably temporary noise or static on the line. Try sending the fax again. If you are sending a PC-Fax message and get RESULT:ERROR on the Transmission Verification Report, your machine may be out of memory. To free up extra memory, you can turn off fax storage (see Advanced User's Guide: <i>Turning off Remote Fax Options</i>), print fax messages in memory (see Advanced User's Guide: <i>Printing a fax from the memory</i>) or cancel a delayed fax or polling job (see Advanced User's Guide: <i>Checking and cancelling waiting jobs</i>). If the problem continues, ask the telephone company to check your telephone line.</p> <p>If you often get transmission errors due to possible interference on the telephone line, try changing the Compatibility setting to Basic (for VoIP) (see <i>Telephone line interference / VoIP</i> on page 144).</p>
Sent faxes are blank.	Make sure you are loading the document correctly. When using the ADF, the document should be <i>face up</i> . When using the scanner glass, the document should be <i>face down</i> (see <i>Loading documents</i> on page 34).
Vertical black lines when sending.	Black vertical lines on faxes you send are typically caused by dirt or correction fluid on the glass strip (see <i>Cleaning the scanner glass</i> on page 98).

## Handling incoming calls

Difficulties	Suggestions
The machine 'Hears' a voice as a CNG Tone.	If Fax Detect is set to On, your machine is more sensitive to sounds. It may mistakenly interpret certain voices or music on the line as a fax machine calling and respond with fax receiving tones. Deactivate the machine by pressing  . Try avoiding this problem by turning Fax Detect to Off (see <i>Fax Detect</i> on page 42).
Sending a Fax Call to the machine.	<p>If you answered on an external or extension telephone, press your Remote Activation Code (default setting is *51).</p> <p>When your machine answers, hang up.</p>
Custom features on a single line.	<p>If you have Call Waiting, Call Waiting/Caller ID, Caller ID, Voice Mail, an answering machine, an alarm system or other custom feature on a single telephone line with your machine, it may create a problem sending or receiving faxes.</p> <p><b>For Example:</b> If you subscribe to Call Waiting or some other custom service and its signal comes through the line while your machine is sending or receiving a fax, the signal can temporarily interrupt or disrupt the faxes. Brother's ECM (Error Correction Mode) feature should help overcome this problem. This condition is related to the telephone system industry and is common to all devices that send and receive information on a single, shared line with custom features. If avoiding a slight interruption is crucial to your business, a separate line with no custom features is recommended.</p>

## Copying difficulties

Difficulties	Suggestions
Cannot make a copy.	<p>Make sure you pressed Copy and the machine is in Copy mode (see <i>How to copy</i> on page 57).</p> <p>Contact your administrator to check your Secure Function Lock Settings.</p>

### Copying difficulties (continued)

Difficulties	Suggestions
Vertical black line appears in copies.	Black vertical lines on copies are typically caused by dirt or correction fluid on the scanner glass, or the corona wires are dirty. Clean the glass strip and scanner glass and also the white bar and white plastic above them (see <i>Cleaning the scanner glass</i> on page 98 and <i>Cleaning the corona wires</i> on page 99).
Copies are blank.	Make sure you are loading the document correctly (see <i>Using the automatic document feeder (ADF)</i> on page 34 or <i>Using the scanner glass</i> on page 35).

### Scanning difficulties

Difficulties	Suggestions
TWAIN or WIA errors appear when starting to scan. (Windows®)	Make sure the Brother TWAIN or WIA driver is selected as the primary source. In PageManager, click <b>File &gt; Select Source</b> and choose the Brother TWAIN/WIA driver.
TWAIN or ICA errors appear when starting to scan. (Macintosh)	Make sure the Brother TWAIN driver is selected as the primary source. In PageManager, click <b>File &gt; Select Source</b> and choose the Brother TWAIN driver.  Macintosh users can also scan documents using the ICA Scanner Driver (see Software User's Guide).
OCR does not work.	Try increasing the scanning resolution.  (Macintosh users) Presto! PageManager must be downloaded and installed before use. For further instructions, see <i>Accessing Brother Support (Macintosh)</i> on page 6.
Network scanning does not work.	See <i>Network difficulties</i> on page 142.
Cannot scan.	Contact your administrator to check your Secure Function Lock Settings.

### Software difficulties





Difficulties	Suggestions
Cannot install software or print.	<b>(Windows® only)</b>  Run the <b>Repair MFL-Pro Suite</b> program on the CD-ROM. This program will repair and reinstall the software.

## Network difficulties

Difficulties	Suggestions
Cannot print and scan over a network after completing the software installation.	<p>When the <i>Cannot print to the networked printer.</i> screen appears, follow the on-screen instructions.</p> <p>If the problem is not solved, see Network User's Guide: <i>Troubleshooting</i>.</p>
The network scanning feature does not work.	<p><b>(Windows® and Macintosh)</b></p> <p>The network scanning feature may not work due to the firewall settings. Change or disable the firewall settings. It is necessary to set the third-party Security/Firewall Software to allow Network scanning. To add port 54925 for Network scanning, enter the information below:</p> <ul style="list-style-type: none"> <li>■ In Name: Enter any description, for example Brother NetScan.</li> <li>■ In Port number: Enter 54925.</li> <li>■ In Protocol: Ensure UDP is selected.</li> </ul> <p>See the instruction manual that came with your third-party Security/Firewall Software or contact the software manufacturer.</p> <p>For more information, you can read FAQs and troubleshooting suggestions at <a href="http://solutions.brother.com/">http://solutions.brother.com/</a>.</p> <p><b>(Macintosh)</b></p> <p>Re-select your machine in the <b>Device Selector</b> window from the Model pop-up menu in the main screen of <b>ControlCenter2</b>.</p>
The network PC-Fax Receive feature does not work.	<p><b>(Windows® only)</b></p> <p>It is necessary to set the third-party Security/Firewall Software to allow PC-FAX Rx. To add port 54926 for Network PC-FAX Rx, enter the information below:</p> <ul style="list-style-type: none"> <li>■ In Name: Enter any description, for example Brother PC-FAX Rx.</li> <li>■ In Port number: Enter 54926.</li> <li>■ In Protocol: UDP is selected.</li> </ul> <p>See the instruction manual that came with your third-party Security/Firewall Software or contact the software manufacturer.</p> <p>For more information, read FAQs and troubleshooting suggestions at <a href="http://solutions.brother.com/">http://solutions.brother.com/</a>.</p>
The Brother software cannot be installed.	<p><b>(Windows®)</b></p> <p>If the Security Software warning appears on the computer screen during the installation, change the Security Software settings to permit the Brother product setup program or other program to run.</p> <p><b>(Macintosh)</b></p> <p>If you are using a firewall function of anti-spyware or antivirus security software, temporarily disable it and then install the Brother software.</p>
Cannot connect to the wireless network. (MFC-9340CDW)	<p>Investigate the problem using the WLAN Report. Press , All Settings, Print Reports, WLAN Report and then press OK (see Quick Setup Guide).</p>



## Other difficulties

Difficulties	Suggestions
<p>The machine will not turn on.</p>	<p>Adverse conditions on the power connection (such as lightning or a power surge) may have triggered the machine's internal safety mechanisms. Press and hold down  to turn off the machine and unplug the power cord. Wait for ten minutes, then plug in the power cord and press  to turn on the machine.</p> <p>If the problem is not solved and you are using a power breaker, disconnect it to make sure it is not the problem. Plug the machine's power cord directly into a different known working wall electrical socket. If there is still no power, try a different power cable.</p>
<p>The machine cannot print EPS data that includes binary with the BR-Script3 printer driver.</p>	<p><b>(Windows®)</b> To print EPS data, do the following:</p> <p><b>1</b> For Windows® 7 and Windows Server® 2008 R2: Click the  (<b>Start</b>) button &gt; <b>Devices and Printers</b>.</p> <p>For Windows Vista® and Windows Server® 2008: Click the  (<b>Start</b>) button &gt; <b>Control Panel</b> &gt; <b>Hardware and Sound</b> &gt; <b>Printers</b>.</p> <p>For Windows® XP and Windows Server® 2003: Click the <b>Start</b> button &gt; <b>Printers and Faxes</b>.</p> <p>For Windows® 8 and Windows Server® 2012: Move your mouse to the lower right corner of your desktop. When the menu bar appears, click <b>Settings</b> &gt; <b>Control Panel</b>. In the <b>Hardware and Sound</b><sup>1</sup> group, click <b>View devices and printers</b>.</p> <p><b>2</b> For Windows® 7, Windows® XP, Windows Vista®, Windows Server® 2003, Windows Server® 2008 and Windows Server® 2008R2: Right-click the <b>Brother MFC-XXXX</b><sup>2</sup> icon and select <b>Printer properties</b><sup>3</sup>, and then select <b>Brother MFC-XXXX BR-Script3</b>.</p> <p>For Windows® 8 and Windows Server® 2012: Right-click the <b>Brother MFC-XXXX BR-Script3</b> icon, select <b>Printer properties</b>.</p> <p><b>3</b> From the <b>Device Settings</b> tab, choose <b>TBCP</b> (Tagged binary communication protocol) in <b>Output Protocol</b>.</p> <p><b>(Macintosh)</b> If your machine is connected to a computer with a USB interface, you cannot print EPS data that includes binary. You can print the EPS data at the machine through a network. For help installing the BR-Script3 printer driver through the network, visit the Brother Solutions Center at <a href="http://solutions.brother.com/">http://solutions.brother.com/</a>.</p>

<sup>1</sup> For Windows Server® 2012: **Hardware**.



<sup>2</sup> For Windows® XP, Windows Vista®, Windows Server® 2003 and Windows Server® 2008: **Brother MFC-XXXX BR-Script3**.

<sup>3</sup> For Windows® XP, Windows Vista®, Windows Server® 2003 and Windows Server® 2008: **Properties**.

## Setting Dial Tone detection

---

When you send a fax automatically, by default your machine will wait for a fixed amount of time before it starts to dial the number. By changing the Dial Tone setting to Detection you can make your machine dial as soon as it detects a dial tone. This setting can save a small amount of time when sending a fax to many different numbers. If you change the setting and start having problems with dialling you should change back to the default No Detection setting.

- 1 Press .
- 2 Press All Settings.
- 3 Swipe up or down, or press ▲ or ▼ to display Initial Setup.
- 4 Press Initial Setup.
- 5 Swipe up or down, or press ▲ or ▼ to display Dial Tone.
- 6 Press Dial Tone.
- 7 Press Detection or No Detection.
- 8 Press .

## Telephone line interference / VoIP

---

If you are having difficulty sending or receiving a fax due to possible interference on the telephone line, we recommend that you adjust the Equalization for compatibility to reduce the modem speed for fax operations.

- 1 Press .
- 2 Press All Settings.
- 3 Swipe up or down, or press ▲ or ▼ to display Initial Setup.

- 4 Press Initial Setup.
- 5 Swipe up or down, or press ▲ or ▼ to display Compatibility.
- 6 Press Compatibility.
- 7 Press High, Normal or Basic(for VoIP).
  - Basic(for VoIP) reduces the modem speed to 9600 bps and turns off ECM (error correction mode). Unless interference is a recurring problem on your telephone line, you may prefer to use it only when needed.

To improve compatibility with most VoIP services, Brother recommends changing the compatibility setting to Basic(for VoIP).
  - Normal sets the modem speed at 14400 bps.
  - High sets the modem speed at 33600 bps.
- 8 Press .

### NOTE

---

- VoIP (Voice over IP) is a type of phone system that uses an Internet connection, rather than a traditional phone line.
  - Brother does not recommend the use of a VoIP line. VoIP limitations in general can cause some functions of the fax machine not to work correctly.
-



# Improving the print quality

If you have a print quality problem, print a test page first ( , All Settings, Printer, Print Options, Test Print). If the printout looks good, the problem is probably not the machine. Check the interface cable connections and try printing a different document. If the printout or test page printed from the machine has a quality problem, check the following steps first. And then, if you still have a print quality problem, check the chart below and follow the recommendations.

## NOTE

Brother does not recommend the use of cartridges other than Brother Original cartridges or the refilling of used cartridges with toner from other sources.

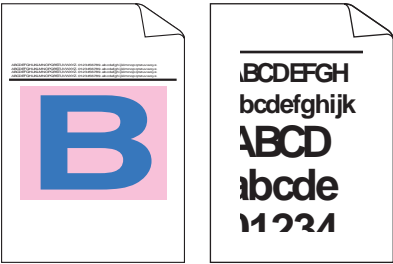
- 1 To get the best print quality, we suggest using recommended paper. Make sure you use paper that meets our specifications (see *Acceptable paper and other print media* on page 29).
- 2 Check that the drum units and toner cartridges are installed correctly.

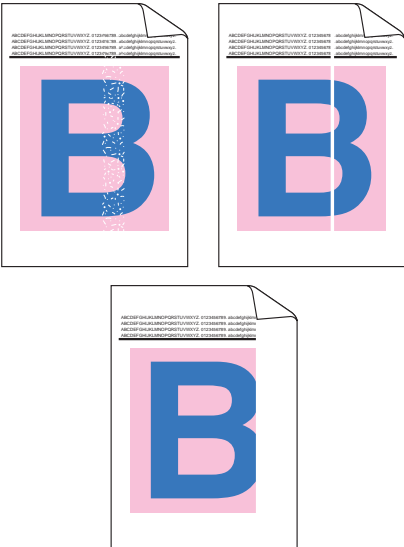

Examples of poor print quality	Recommendation
 <p><b>Printed pages are compressed, horizontal stripes appear, or characters in the top, bottom, left and right margins are cut off</b></p>	<ul style="list-style-type: none"> <li>■ Adjust the print margins on your application and reprint the job.</li> </ul>
 <p><b>Coloured letters and thin letters in the original document are unclear in the copy</b></p>	<ul style="list-style-type: none"> <li>■ Choose <i>Text</i> or <i>Receipt</i> in the copy quality setting (see <i>Advanced User's Guide: Improving copy quality</i>).</li> <li>■ Adjust the copy density and contrast (see <i>Advanced User's Guide: Adjusting Density and Contrast</i>).</li> </ul>

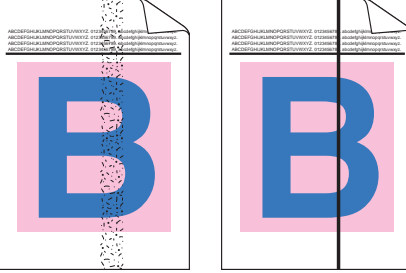
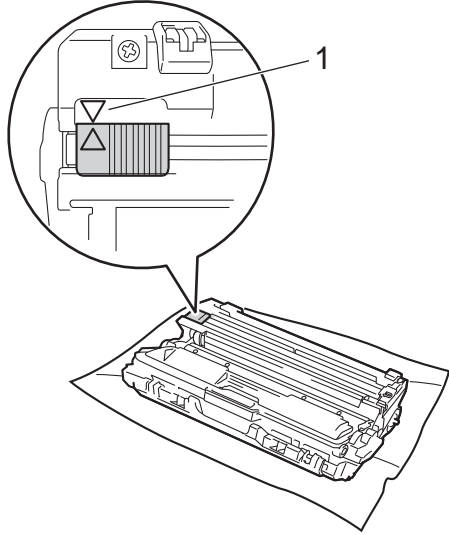
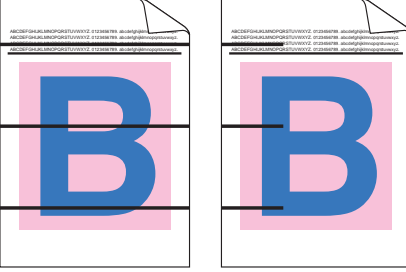
Examples of poor print quality	Recommendation
 <p data-bbox="120 556 514 614"><b>Colours are light or unclear on the whole page</b></p>	<ul style="list-style-type: none"> <li data-bbox="550 266 1204 324">■ Perform the calibration using the Touchscreen or the printer driver (see <i>Calibration</i> on page 109).</li> <li data-bbox="550 340 1159 421">■ Adjust the copy density and contrast if you are copying (see <i>Advanced User's Guide: Adjusting Density and Contrast</i>).</li> <li data-bbox="550 436 1204 494">■ Make sure Toner Save mode is off in the Touchscreen or the printer driver.</li> <li data-bbox="550 510 1204 591">■ Make sure the media type setting in the driver matches the type of paper you are using (see <i>Acceptable paper and other print media</i> on page 29).</li> <li data-bbox="550 606 975 635">■ Shake all four toner cartridges gently.</li> <li data-bbox="550 651 1195 709">■ Wipe the windows of all four LED heads with a <i>dry</i> lint free soft cloth (see <i>Cleaning the LED heads</i> on page 97).</li> </ul>
 <p data-bbox="127 1284 506 1342"><b>White streaks or bands down the page</b></p>	<ul style="list-style-type: none"> <li data-bbox="550 720 1195 778">■ Wipe the windows of all four LED heads with a <i>dry</i> lint free soft cloth (see <i>Cleaning the LED heads</i> on page 97).</li> <li data-bbox="550 794 1177 852">■ Wipe the scanner glass strip with a <i>dry</i> lint free soft cloth (see <i>Cleaning the scanner glass</i> on page 98).</li> <li data-bbox="550 867 1204 948">■ Make sure foreign material such as a torn piece of paper, sticky notes or dust is not inside the machine and around the drum unit and toner cartridge.</li> <li data-bbox="550 964 1092 1022">■ Clean the drum unit (see <i>Cleaning the drum unit</i> on page 102).</li> </ul>

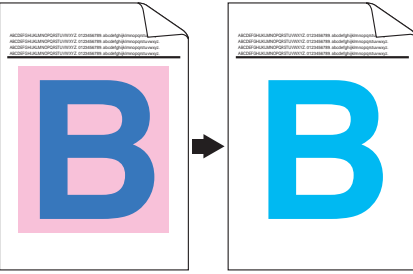
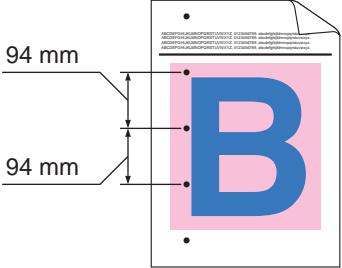
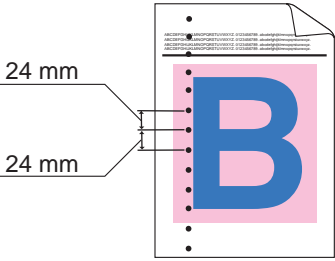
Examples of poor print quality	Recommendation
 <p data-bbox="157 598 535 666"><b>Coloured streaks or bands down the page</b></p>	<ul style="list-style-type: none"> <li>■ Wipe the scanner glass strip with a <i>dry</i> lint free soft cloth (see <i>Cleaning the scanner glass</i> on page 98).</li> <li>■ Clean all four corona wires (one for each colour) inside the drum unit by sliding the green tab (see <i>Cleaning the corona wires</i> on page 99).</li> <li>■ Make sure the green tab of the corona wire is at the home position (▲)(1).</li> </ul>  <ul style="list-style-type: none"> <li>■ Replace the toner cartridge that matches the colour of the streak or band (see <i>Replacing the toner cartridges</i> on page 74). To identify the colour of the toner cartridge, visit us at <a href="http://solutions.brother.com/">http://solutions.brother.com/</a> to view our FAQs and troubleshooting tips.</li> <li>■ The drum unit may be damaged. Install a new drum unit (see <i>Replacing the drum units</i> on page 81.) To identify the colour of the drum unit, visit us at <a href="http://solutions.brother.com/">http://solutions.brother.com/</a> to view our FAQs and troubleshooting tips.</li> </ul>
 <p data-bbox="164 1729 528 1758"><b>Coloured lines across the page</b></p>	<ul style="list-style-type: none"> <li>■ Identify the colour causing the problem and replace the toner cartridge that matches the colour of the line (see <i>Replacing the toner cartridges</i> on page 74). To identify the colour of the toner cartridge, visit us at <a href="http://solutions.brother.com/">http://solutions.brother.com/</a> to view our FAQs and troubleshooting tips.</li> <li>■ Identify the colour causing the problem and install a new drum unit (see <i>Replacing the drum units</i> on page 81). To identify the colour of the drum unit, visit us at <a href="http://solutions.brother.com/">http://solutions.brother.com/</a> to view our FAQs and troubleshooting tips.</li> </ul>

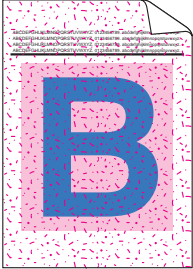
Examples of poor print quality	Recommendation
 <p data-bbox="161 562 474 591"><b>White spots or hollow print</b></p>	<ul style="list-style-type: none"> <li data-bbox="550 266 1204 349">■ Make sure the media type setting in the driver matches the type of paper you are using (see <i>Acceptable paper and other print media</i> on page 29).</li> <li data-bbox="550 365 1204 479">■ Check the machine's environment. Conditions such as high humidity can cause hollow print (see <i>Product Safety Guide: Choose a safe location for your product</i>).</li> <li data-bbox="550 494 1204 581">■ If the problem is not solved after printing a few pages, foreign material, such as glue from a label, may be stuck on the drum surface (see <i>Cleaning the drum unit</i> on page 102).</li> <li data-bbox="550 596 1204 749">■ Identify the colour causing the problem and install a new drum unit (see <i>Replacing the drum units</i> on page 81). To identify the colour of the drum unit, visit us at <a href="http://solutions.brother.com/">http://solutions.brother.com/</a> to view our FAQs and troubleshooting tips.</li> </ul>
 <p data-bbox="134 1058 502 1112"><b>Blank page or some colours are missing</b></p>	<ul style="list-style-type: none"> <li data-bbox="550 768 1204 952">■ Identify the colour causing the problem and put in a new toner cartridge (see <i>Replacing the toner cartridges</i> on page 74). To identify the colour of the toner cartridge, visit us at <a href="http://solutions.brother.com/">http://solutions.brother.com/</a> to view our FAQs and troubleshooting tips.</li> <li data-bbox="550 967 1204 1122">■ Identify the colour causing the problem and install a new drum unit (see <i>Replacing the drum units</i> on page 81). To identify the colour of the drum unit, visit us at <a href="http://solutions.brother.com/">http://solutions.brother.com/</a> to view our FAQs and troubleshooting tips.</li> </ul>
 <p data-bbox="172 1431 463 1460"><b>Coloured spots at 94 mm</b></p>	<ul style="list-style-type: none"> <li data-bbox="550 1141 1204 1251">■ If the problem is not solved after printing a few blank pages, foreign material, such as glue from a label, may be stuck on the drum surface. Clean the drum unit (see <i>Cleaning the drum unit</i> on page 102).</li> <li data-bbox="550 1267 1204 1421">■ Identify the colour causing the problem and install a new drum unit (see <i>Replacing the drum units</i> on page 81). To identify the colour of the drum unit, visit us at <a href="http://solutions.brother.com/">http://solutions.brother.com/</a> to view our FAQs and troubleshooting tips.</li> </ul>
 <p data-bbox="172 1750 463 1779"><b>Coloured spots at 24 mm</b></p>	<ul style="list-style-type: none"> <li data-bbox="550 1470 1204 1653">■ Identify the colour causing the problem and put in a new toner cartridge (see <i>Replacing the toner cartridges</i> on page 74). To identify the colour of the toner cartridge, visit us at <a href="http://solutions.brother.com/">http://solutions.brother.com/</a> to view our FAQs and troubleshooting tips.</li> </ul>

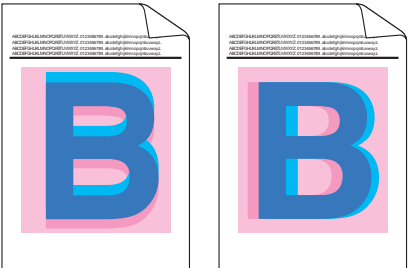
Examples of poor print quality	Recommendation
 <p data-bbox="190 558 504 585"><b>Toner scatter or toner stain</b></p>	<ul style="list-style-type: none"> <li data-bbox="581 266 1232 349">■ Check the machine's environment. Conditions such as high humidity and high temperatures may cause this print quality problem.</li> <li data-bbox="581 369 1201 452">■ Identify the colour causing the problem and put in a new toner cartridge (see <i>Replacing the toner cartridges</i> on page 74).  To identify the colour of the toner cartridge, visit us at <a href="http://solutions.brother.com/">http://solutions.brother.com/</a> to view our FAQs and troubleshooting tips.</li> <li data-bbox="581 568 1201 651">■ Identify the colour causing the problem and install a new drum unit (see <i>Replacing the drum units</i> on page 81).  To identify the colour of the drum unit, visit us at <a href="http://solutions.brother.com/">http://solutions.brother.com/</a> to view our FAQs and troubleshooting tips.</li> </ul>
<p data-bbox="152 739 541 790"><b>The colour of your printouts is not what you expected</b></p>	<ul style="list-style-type: none"> <li data-bbox="581 739 1212 823">■ To improve the colour density, calibrate the colours using first the Touchscreen and then the printer driver (see <i>Calibration</i> on page 109).</li> <li data-bbox="581 842 1199 925">■ To adjust the print position of colours for sharper edges, perform an automatic colour registration using the Touchscreen (see <i>Auto Registration</i> on page 110).</li> <li data-bbox="581 944 1185 1027">■ Adjust the copy density and contrast if you are copying (see <i>Advanced User's Guide: Adjusting Density and Contrast</i>).</li> <li data-bbox="581 1047 1232 1097">■ Make sure Toner Save mode is off in the Touchscreen or the printer driver (see <i>Software User's Guide</i>).</li> <li data-bbox="581 1116 1232 1166">■ If the print quality is poor, clear the <b>Improve Gray Color</b> check box in the printer driver (see <i>Software User's Guide</i>).</li> <li data-bbox="581 1186 1232 1269">■ If the print quality of the black portion is not what you expected, select the <b>Enhance Black Printing</b> check box in the printer driver (see <i>Software User's Guide</i>).</li> <li data-bbox="581 1288 1201 1371">■ Identify the colour causing the problem and put in a new toner cartridge (see <i>Replacing the toner cartridges</i> on page 74).  To identify the colour of the toner cartridge, visit us at <a href="http://solutions.brother.com/">http://solutions.brother.com/</a> to view our FAQs and troubleshooting tips.</li> <li data-bbox="581 1487 1201 1570">■ Identify the colour causing the problem and install a new drum unit (see <i>Replacing the drum units</i> on page 81).  To identify the colour of the drum unit, visit us at <a href="http://solutions.brother.com/">http://solutions.brother.com/</a> to view our FAQs and troubleshooting tips.</li> </ul>

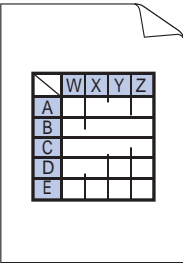
Examples of poor print quality	Recommendation
 <p data-bbox="189 556 447 581"><b>Colour misregistration</b></p>	<ul style="list-style-type: none"> <li data-bbox="552 266 1108 291">■ Make sure the machine is on a solid level surface.</li> <li data-bbox="552 307 1201 363">■ Perform the auto colour registration using the Touchscreen (see <i>Auto Registration</i> on page 110).</li> <li data-bbox="552 378 1174 434">■ Identify the colour causing the problem and install a new drum unit (see <i>Replacing the drum units</i> on page 81). To identify the colour of the drum unit, visit us at <a href="http://solutions.brother.com/">http://solutions.brother.com/</a> to view our FAQs and troubleshooting tips.</li> <li data-bbox="552 552 1101 608">■ Install a new belt unit (see <i>Replacing the belt unit</i> on page 86).</li> </ul>
 <p data-bbox="156 911 480 967"><b>Uneven density appears periodically across the page</b></p>	<ul style="list-style-type: none"> <li data-bbox="552 622 1201 678">■ Perform the calibration using the Touchscreen or the printer driver (see <i>Calibration</i> on page 109).</li> <li data-bbox="552 693 1156 778">■ Adjust the copy density and contrast if you are copying (see <i>Advanced User's Guide: Adjusting Density and Contrast</i>).</li> <li data-bbox="552 794 1160 850">■ Clear the <b>Improve Gray Color</b> check box in the printer driver. (See <i>Software User's Guide</i>.)</li> <li data-bbox="552 865 1170 950">■ Identify the colour causing the problem and put in a new toner cartridge (see <i>Replacing the toner cartridges</i> on page 74). To identify the colour of the toner cartridge, visit us at <a href="http://solutions.brother.com/">http://solutions.brother.com/</a> to view our FAQs and troubleshooting tips.</li> <li data-bbox="552 1068 1174 1124">■ Identify the colour causing the problem and install a new drum unit (see <i>Replacing the drum units</i> on page 81). To identify the colour of the drum unit, visit us at <a href="http://solutions.brother.com/">http://solutions.brother.com/</a> to view our FAQs and troubleshooting tips.</li> </ul>
 <p data-bbox="156 1522 480 1547"><b>Missing thin lines in images</b></p>	<ul style="list-style-type: none"> <li data-bbox="552 1236 1201 1292">■ Make sure Toner Save mode is off in the Touchscreen or the printer driver (see <i>Software User's Guide</i>).</li> <li data-bbox="552 1307 872 1333">■ Change the print resolution.</li> <li data-bbox="552 1348 1146 1433">■ If you use a Windows printer driver, choose <b>Improve pattern printing</b> in Print Setting of Basic tab (see <i>Software User's Guide</i>).</li> </ul>

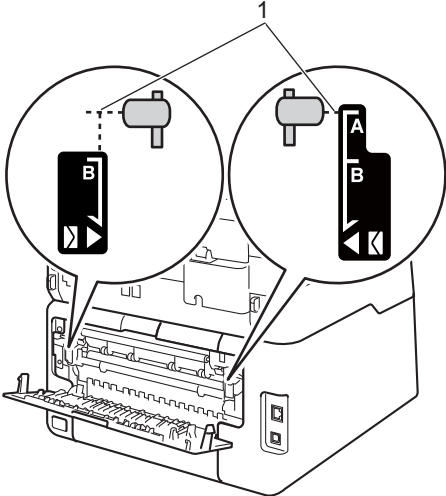

Examples of poor print quality	Recommendation
 <p data-bbox="303 556 391 581"><b>Wrinkle</b></p>	<ul style="list-style-type: none"> <li data-bbox="581 266 1085 291">■ Make sure the back cover is closed correctly.</li> <li data-bbox="581 307 1240 363">■ Make sure the two grey levers inside the back cover are in the up position (1). Pull up the two grey levers until they stop.</li> </ul>  <ul style="list-style-type: none"> <li data-bbox="581 902 1240 987">■ Make sure the media type setting in the driver matches the type of paper you are using (see <i>Acceptable paper and other print media</i> on page 29).</li> </ul>

### Examples of poor print quality

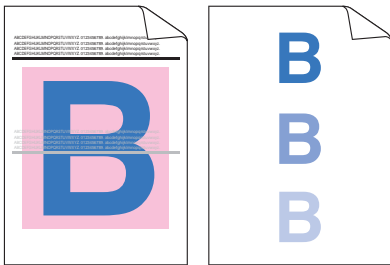

**Ghost**

### Recommendation

- Check the machine's environment. Conditions such as low humidity and low temperatures may cause this print quality problem (see *Product Safety Guide: Choose a safe location for your product*).
- Make sure the media type setting in the driver matches the type of paper you are using (see *Acceptable paper and other print media* on page 29).
- Make sure the two grey levers inside the back cover are in the up position (1). Pull up the two grey levers until they stop.

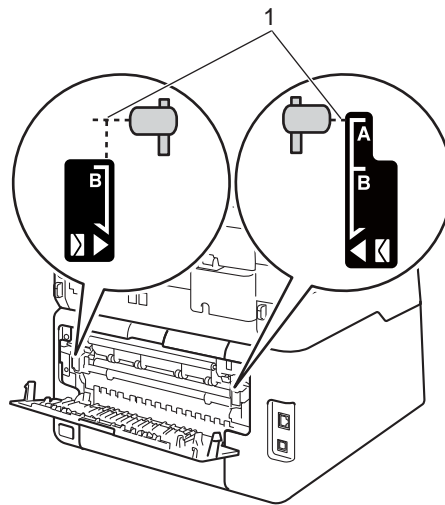

- Identify the colour causing the problem and install a new drum unit (see *Replacing the drum units* on page 81).

To identify the colour of the drum unit, visit us at <http://solutions.brother.com/> to view our FAQs and troubleshooting tips.

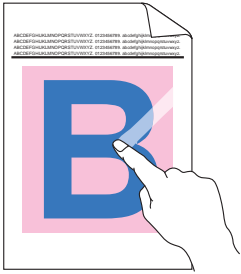
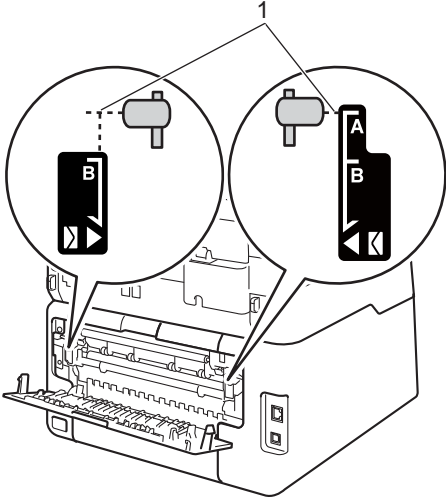
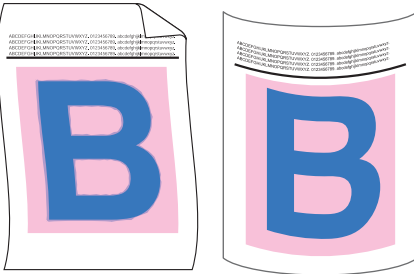
Examples of poor print quality	Recommendation
 <p data-bbox="285 571 408 600">Poor fixing</p>	<ul style="list-style-type: none"> <li>■ Make sure the two grey levers inside the back cover are in the up position (1). Pull up the two grey levers until they stop.</li> </ul>  <ul style="list-style-type: none"> <li>■ Make sure the media type setting in the driver matches the type of paper you are using (see <i>Acceptable paper and other print media</i> on page 29).</li> <li>■ Choose <b>Improve Toner Fixing</b> mode in the printer driver (see Software User's Guide). If this selection does not provide enough improvement, change the printer driver setting in <b>Media Type</b> to a thick setting. If you are printing an envelope, choose <b>Env. Thick</b> in the media type setting.</li> </ul>
 <p data-bbox="262 1452 433 1481">Curled or wavy</p>	<ul style="list-style-type: none"> <li>■ Choose <b>Reduce Paper Curl</b> mode in the printer driver (see Software User's Guide). If the problem is not solved, choose <b>Plain Paper</b> in the media type setting.</li> <li>■ If you are printing an envelope, choose <b>Env. Thin</b> in the Media Type Setting of the printer driver.</li> <li>■ If you do not use the machine often, the paper may have been in the paper tray too long. Turn over the stack of paper in the paper tray. Also, fan the paper stack and then rotate the paper 180° in the paper tray.</li> <li>■ Store the paper where it will not be exposed to high temperatures and high humidity.</li> <li>■ Open the back cover (face-up output tray) to let the printed paper exit onto the face-up output tray.</li> </ul>

### Examples of poor print quality



Envelope Creases

### Recommendation

- Make sure the envelope levers inside the back cover are pulled down to the envelope position when you print envelopes (see *Loading paper in the manual feed slot* on page 23).

### NOTE

When you have finished printing, open the back cover and reset the two grey levers back to their original positions (1). Pull up the two grey levers until they stop.

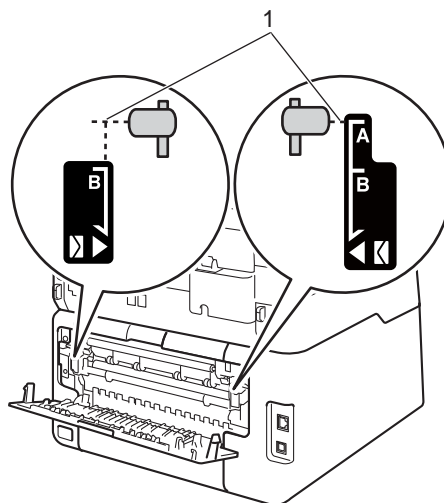



## Machine Information

### Checking the Serial Number

---



You can see the machine's Serial Number on the Touchscreen.

- 1 Press .
- 2 Press All Settings.
- 3 Swipe up or down, or press ▲ or ▼ to display Machine Info..
- 4 Press Machine Info..
- 5 Press Serial No..
- 6 The Touchscreen will display the machines Serial Number.
- 7 Press .

### Checking the Firmware Version

---

You can see the machine's firmware version on the Touchscreen.

- 1 Press .
- 2 Press All Settings.
- 3 Swipe up or down, or press ▲ or ▼ to display Machine Info..
- 4 Press Machine Info..
- 5 Press Firmware Version.
- 6 The Touchscreen will display the machine's firmware version information.
- 7 Press .

## Reset functions

The following reset functions are available:

### 1 Network

You can reset the internal print server back to its default factory settings such as the password and IP address information.

### 2 Address Book & Fax

Address book & Fax resets the following settings:

- Address Book  
(Addresses and Groups)
- Programmed fax jobs in the memory  
(Polled TX, Delayed Fax, Batch TX)
- Station ID  
(name and number)
- Coverage Msg  
(comments)
- Remote Fax Options  
(Remote Access Code, Fax Storage, Fax Forwarding, PC-Fax Send, and PC-Fax Receive (Windows® only))
- Report settings  
(Transmission Verification Report/ Tel Index List/Fax Journal)
- Setting Lock password

### 3 All Settings

You can reset all the machine's settings back to the factory default.

Brother strongly recommends you perform this operation when you dispose of the machine.

## NOTE

Unplug the interface cable before you choose **Network** or **All Settings**.

## How to reset the machine

- 1 Press .
- 2 Press **All Settings**.
- 3 Swipe up or down, or press ▲ or ▼ to display **Initial Setup**.
- 4 Press **Initial Setup**.
- 5 Swipe up or down, or press ▲ or ▼ to display **Reset**.
- 6 Press **Reset**.
- 7 Press **Network**, **Address Book & Fax** or **All Settings** to choose the reset function you want.
- 8 Do one of the following;
  - To reset the settings, press **Yes** and go to step 9.
  - To exit without making changes, press **No** and go to step 10.
- 9 You will be asked to reboot the machine. Do one of the following;
  - To reboot the machine press **Yes** for 2 seconds. The machine will begin the reboot.
  - To exit without rebooting the machine, press **No**. Go to step 10.

## NOTE

If you do not reboot your machine, the reset will not finish and your settings will remain unchanged.

- 10 Press .

## NOTE

You can also reset the Network settings by pressing , **All Settings**, **Network**, **Network Reset**.

## Using the Settings Tables



Your machine's Touchscreen LCD is easy to set up and operate. All you have to do is press the settings and options you want as they are displayed on the screen. We created step-by-step Settings Tables and Features Tables so you can see at-a-glance all the available choices for each setting and feature. You can use these tables to quickly set up your preferred settings in the machine.

# Settings Tables



The Settings tables will help you understand the menu selections and options that are found in the machine's programs. The factory settings are shown in Bold with an asterisk.



## (Settings)

Level 1	Level 2	Level 3	Options	Descriptions	See Page
 (Date & Time)	Date	—	—	Add the date and time on the Touchscreen and in headings of faxes you send.	See ‡.
	Time	—	—		
	Time Zone	—	UTCXXX:XX	Set the time zone for your country.	
 (Toner)	See <i>Toner</i> on page 200.			Access the <i>Toner</i> menus.	200
Network	Wired LAN	See <i>Wired LAN</i> on page 167.		Access the Wired LAN setting menus.	167
	WLAN (MFC-9340CDW)	See <i>WLAN</i> on page 169.		Access the WLAN setting menus.	169
Fax Preview	—	—	On Off*	View faxes you receive on the Touchscreen.	43
Wi-Fi Direct (MFC-9340CDW)	See <i>Wi-Fi Direct</i> on page 171.			Access the Wi-Fi Direct™ setting menus.	171
Tray Setting (MFC-9340CDW)	Paper Type	—	Thin <b>Plain Paper*</b> Thick Thicker Recycled Paper	Set the type of paper in the paper tray.	28
◆ Advanced User's Guide ‡ Quick Setup Guide					
 The factory settings are shown in Bold with an asterisk.					







Level 1	Level 2	Level 3	Options	Descriptions	See Page
Tray Setting (MFC-9340CDW) (continued)	Paper Size	—	<b>A4*</b> Letter Legal EXE A5 A5 L A6 Folio 16K (195x270mm) 16K (184x260mm) 16K (197x273mm)	Set the size of paper in the paper tray.	28
 (Paper Type) (MFC-9140CDN)	—	—	Thin <b>Plain Paper*</b> Thick Thicker Recycled Paper	Set the type of paper in the paper tray.	28
 (Paper Size) (MFC-9140CDN)	—	—	<b>A4*</b> Letter Legal EXE A5 A5 L A6 Folio 16K (195x270mm) 16K (184x260mm) 16K (197x273mm)	Set the size of paper in the paper tray.	28
<b>All settings</b>	See <i>All settings</i> on page 160.			Select your default settings.	160
◆ Advanced User's Guide					
‡ Quick Setup Guide					
 The factory settings are shown in Bold with an asterisk.					





## All settings

Level 1	Level 2	Level 3	Level 4	Options	Descriptions	See Page	
General Setup	Paper Type	—	—	Thin <b>Plain Paper*</b> Thick Thicker Recycled Paper	Set the type of paper in the paper tray.	28	
	Paper Size	—	—	<b>A4*</b> Letter Legal EXE A5 A5 L A6 Folio 16K(195x270mm) 16K(184x260mm) 16K(197x273mm)	Set the size of paper in the paper tray.	28	
	Volume	Ring	—	—	Off Low <b>Med*</b> High	Adjust the ring volume.	20
		Beep	—	—	Off <b>Low*</b> Med High	Adjust the beeper volume.	20
		Speaker	—	—	Off Low <b>Med*</b> High	Adjust the speaker volume.	20
LCD Settings	Backlight	—	—	<b>Light*</b> Med Dark	Adjust the brightness of the Touchscreen backlight.	See <b>◆</b> .	
<b>◆ Advanced User's Guide</b>							
 The factory settings are shown in <b>Bold</b> with an asterisk.							

Level 1	Level 2	Level 3	Level 4	Options	Descriptions	See Page	
General Setup (continued)	LCD Settings (continued)	Dim Timer	—	<b>Off*</b> 10Secs 20Secs 30Secs	Set how long the Touchscreen backlight stays on for after the last key press.	See  .	
		Button Settings	<b>Home Button Settings</b>	—	<b>Home*</b> More Shortcuts 1 Shortcuts 2 Shortcuts 3	Set the screen that is displayed when you press Home (  ) on the Touchpanel.	13
	Ecology	Toner Save	—	On <b>Off*</b>	Increase the page yield of the toner cartridge.	See  .	
		Sleep Time	—	Range varies depending on the model. <b>3 Mins*</b>	Conserve power.		
	Security	Function Lock	Set Password	Verify	You can restrict selected machine operations for up to 25 restricted users and for all other non-authorized Public users.		
			Lock Off⇒On				
		Setting Lock	Set Password	Verify:		Stop unauthorized users from changing the machine's settings.	
			Lock Off⇒On				
	Shortcut Settings	(Choose shortcut button.)	Edit Shortcut Name	—	—	Change the shortcut name.	19
			Delete	—	—	Delete the shortcut.	19
◆ Advanced User's Guide							
 The factory settings are shown in Bold with an asterisk.							

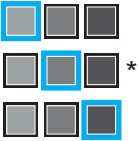

Level 1	Level 2	Level 3	Level 4	Options	Descriptions	See Page		
Fax (continued)	Setup Receive (continued)	Anti-Junk Fax	—	Register	Register up to 100 fax/telephone numbers to the fax blocking list.	See <b>◆</b> .		
				Delete	Delete registered fax/telephone numbers from the fax blocking list.			
				Print Reports	Print a list of registered fax/telephone numbers in the fax blocking list.			
		Print Density	—	 *	Make printouts darker or lighter.			
		Fax Rx Stamp	—	On <b>Off*</b>	Print the received time and date on the top of the received faxes.			
		2-sided	—	On <b>Off*</b>	Print received faxes on both sides of the paper.			
	Setup Send	Batch TX	—	—	On <b>Off*</b>	Combine delayed faxes going to the same fax number at the same time of day into one transmission.		
					Coverage Setting	Print Sample	—	Print a sample of the fax cover page. You can fill in information and fax it with your document.
						Coverage Note	—	Set up your own comments for the fax cover page.
					Destination	—	<b>Display*</b> Hidden	Set the machine to display the destination information on the Touchscreen during fax sending.
	◆ Advanced User's Guide							
	 The factory settings are shown in Bold with an asterisk.							

Level 1	Level 2	Level 3	Level 4	Options	Descriptions	See Page
Fax (continued)	Report Setting	Transmission	—	On On+Image <b>Off*</b> Off+Image	Choose the initial setup for the Transmission Verification Report.	38
		Journal Period	Journal Period	Off <b>Every 50 Faxes*</b> Every 6 Hours Every 12 Hours Every 24 Hours Every 2 Days Every 7 Days	Set the interval for automatic printing of the Fax Journal.  If you select other than Off or Every 50 Faxes, you can set the time for the option.  If you select Every 7 Days, you can also set the day of the week.	See  .
			Time	—		
			Day	<b>Every Monday*</b> Every Tuesday Every Wednesday Every Thursday Every Friday Every Saturday Every Sunday		
	Print Document	—	—	—	Print incoming faxes that are stored in the memory.	
	Remote Access	—	—	---*	Set your own code for Remote Retrieval.	
	Dial Restriction	Dial Pad	—	Enter # Twice On <b>Off*</b>	Set the machine to restrict dialling when using the dial pad.	
		Address Book	—	Enter # Twice On <b>Off*</b>	Set the machine to restrict the dialling when using the Address Book.	
		Shortcuts	—	Enter # Twice On <b>Off*</b>	Set the machine to restrict the dialling when using a Shortcut.	
	Remaining Jobs	—	—	—	Check which scheduled jobs are in the memory and cancel selected jobs.	

 Advanced User's Guide



The factory settings are shown in Bold with an asterisk.

Level 1	Level 2	Level 3	Level 4	Options	Descriptions	See Page
<b>Fax</b> (continued)	Miscellaneous	Caller ID Type	—	<b>Auto*</b> FSK DTMF	Choose the caller ID transmitting standard.	See <b>◆</b> .
		<b>Fax Mode</b>		<b>Easy Mode*</b> Advanced Mode	Choose the transmission process when sending/receiving the faxes manually.	
◆ Advanced User's Guide						
 The factory settings are shown in Bold with an asterisk.						

Level 1	Level 2	Level 3	Level 4	Options	Descriptions	See Page
Printer	<b>Emulation</b>	—	—	<b>Auto*</b> HP LaserJet BR-Script 3	Choose the emulation mode.	See <input type="checkbox"/> .
	<b>Print Options</b>	<b>Internal Font</b>	HP LaserJet BR-Script 3	—	Print a list of the machine's internal fonts.	
		<b>Configuration</b>	—	—	Print a list of the machine's printer settings.	
		<b>Test Print</b>	—	—	Print a test page.	
	<b>2-sided</b>	—	—	<b>Off*</b> Long Edge Short Edge	Enable or disable 2-sided printing and choose long edge or short edge.	
	<b>Auto Continue</b>	—	—	<b>On*</b> Off	Select this setting if you want the machine to clear paper size errors and to use the paper in the tray.	
	<b>Output Colour</b>	—	—	<b>Auto*</b> Colour Black and White	Choose colour or black & white for printed documents. If you choose <b>Auto</b> , the machine selects an appropriate option for the document (colour or black & white).	
	<b>Reset Printer</b>	—	—	Yes No	Restore the printer settings to the factory settings.	
	<b>Calibration</b>	<b>Calibrate</b>	—	Yes No	Adjust the colour density.	109
		<b>Reset</b>	—	Yes No	Return the colour calibration to the factory settings.	
<b>Auto Regist.</b>	—	—	Yes No	Adjust the print position of each colour automatically.	110	
<b>Frequency</b>	—	—	<b>Normal*</b> Low Off	Set the interval time of the auto registration and calibration.	111	
<input type="checkbox"/> Software User's Guide						
 The factory settings are shown in Bold with an asterisk.						



Level 1	Level 2	Level 3	Level 4	Level 5	Options	Descriptions
Network †	Wired LAN	TCP/IP	BOOT Method	—	<b>Auto*</b> Static RARP BOOTP DHCP	Choose the BOOT method that best suits your needs.
			(IP Boot Tries)		<b>3*</b> [0-32767]	Specifies the number of attempts the machine will try to obtain an IP address when the BOOT Method is set to any setting except Static.
			IP Address	—	[000-255]. [000-255]. [000-255]. [000-255]	Enter the IP address.
			Subnet Mask	—	[000-255]. [000-255]. [000-255]. [000-255]	Enter the Subnet mask.
			Gateway	—	[000-255]. [000-255]. [000-255]. [000-255]	Enter the Gateway address.
			Node Name	—	BRNXXXXXXXXXXXX	Enter the Node name. (Up to 32 characters)
			WINS Configuration	—	<b>Auto*</b> Static	Choose the WINS configuration mode.
WINS Server	—	Primary [000-255]. [000-255]. [000-255]. [000-255] Secondary [000-255]. [000-255]. [000-255]. [000-255]	Specifies the IP address of the primary or secondary WINS server.			
† Network User's Guide ♣ Visit the Brother Solutions Center to download the Wi-Fi Direct™ Guide at <a href="http://solutions.brother.com/">http://solutions.brother.com/</a> .						
 The factory settings are shown in Bold with an asterisk.						

Level 1	Level 2	Level 3	Level 4	Level 5	Options	Descriptions
Network + (continued)	Wired LAN (continued)	TCP/IP (continued)	DNS Server	—	Primary [000-255]. [000-255]. [000-255]. [000-255] Secondary [000-255]. [000-255]. [000-255]. [000-255]	Specifies the IP address of the primary or secondary DNS server.
			APIPA	—	On* Off	Automatically allocate the IP address from the link-local address range.
			IPv6	—	On Off*	Enable or Disable the IPv6 protocol. If you want to use the IPv6 protocol, visit <a href="http://solutions.brother.com/">http://solutions.brother.com/</a> for more information.
		Ethernet	—	—	Auto* 100B-FD 100B-HD 10B-FD 10B-HD	Choose the Ethernet link mode.
		Wired Status	—	—	Active 100B-FD Active 100B-HD Active 10B-FD Active 10B-HD Inactive Wired OFF	You can see the current wired status.
		MAC Address	—	—	—	Shows the MAC address of the machine.
		Set to Default	—	—	Yes No	Restore the wired network setting to the factory setting.
		Wired Enable (MFC-9340CDW)	—	—	On* Off	Enable or Disable the Wired LAN manually.

+ Network User's Guide

♣ Visit the Brother Solutions Center to download the Wi-Fi Direct™ Guide at <http://solutions.brother.com/>.



The factory settings are shown in Bold with an asterisk.

Level 1	Level 2	Level 3	Level 4	Level 5	Options	Descriptions
Network + (continued)	WLAN (MFC-9340CDW)	TCP/IP	BOOT Method	—	<b>Auto*</b> Static RARP BOOTP DHCP	Choose the BOOT method that best suits your needs.
			(IP Boot Tries)	—	<b>3*</b> [00000-32767]	Specifies the number of attempts the machine will try to obtain an IP address when the BOOT Method is set to any setting except Static.
			IP Address	—	[000-255]. [000-255]. [000-255]. [000-255]	Enter the IP address.
			Subnet Mask	—	[000-255]. [000-255]. [000-255]. [000-255]	Enter the Subnet mask.
			Gateway	—	[000-255]. [000-255]. [000-255]. [000-255]	Enter the Gateway address.
			Node Name	—	BRWXXXXXXXXXXXX	Enter the Node name. (Up to 32 characters)
			WINS Configuration	—	<b>Auto*</b> Static	Choose the WINS configuration mode.
			WINS Server	—	Primary [000-255]. [000-255]. [000-255]. [000-255] Secondary [000-255]. [000-255]. [000-255]. [000-255]	Specifies the IP address of the primary or secondary WINS server.
<p>+ Network User's Guide</p> <p>♣ Visit the Brother Solutions Center to download the Wi-Fi Direct™ Guide at <a href="http://solutions.brother.com/">http://solutions.brother.com/</a>.</p>						
<p> The factory settings are shown in Bold with an asterisk.</p>						

Level 1	Level 2	Level 3	Level 4	Level 5	Options	Descriptions
Network + (continued)	WLAN (MFC-9340CDW) (continued)	TCP/IP (continued)	DNS Server	—	Primary [000-255]. [000-255]. [000-255]. [000-255] Secondary [000-255]. [000-255]. [000-255]. [000-255]	Specifies the IP address of the primary or secondary DNS server.
			APIPA	—	On* Off	Automatically allocate the IP address from the link-local address range.
			IPv6	—	On Off*	Enable or Disable the IPv6 protocol. If you want to use the IPv6 protocol, visit <a href="http://solutions.brother.com/">http://solutions.brother.com/</a> for more information.
		Setup Wizard	—	—	—	You can configure your internal print server.
		WPS/AOSS	—	—	—	You can easily configure your wireless network settings using the one-button push method.
		WPS w/ PIN Code	—	—	—	You can easily configure your wireless network settings using WPS with a PIN code.
		WLAN Status	Status	—	Active(11b) Active(11g) Active(11n) Wired LAN Active WLAN Off AOSS Active Connection Failed	You can see the current wireless network status.

+ Network User's Guide

♣ Visit the Brother Solutions Center to download the Wi-Fi Direct™ Guide at <http://solutions.brother.com/>.



The factory settings are shown in Bold with an asterisk.

Level 1	Level 2	Level 3	Level 4	Level 5	Options	Descriptions	
Network + (continued)	WLAN (MFC-9340CDW) (continued)	WLAN Status (continued)	Signal	—	Strong Medium Weak None	You can see the current wireless network signal strength.	
			SSID	—	—	You can see the current SSID.	
			Comm. Mode	—	Ad-hoc Infrastructure None	You can see the current Communication Mode.	
		MAC Address	—	—	—	Shows the MAC address of the machine.	
		Set to Default	—	—	Yes No	Restore the wireless network settings to factory setting.	
		WLAN Enable	—	—	On <b>off*</b>	Enable or disable the wireless LAN manually.	
	Wi-Fi Direct ♣ (MFC-9340CDW)	Push Button	—	—	—	You can easily configure your Wi-Fi Direct™ network settings using the one-button push method.	
			PIN Code	—	—	—	You can easily configure your Wi-Fi Direct™ network settings using WPS with a PIN code.
			Manual	—	—	—	You can manually configure your Wi-Fi Direct™ network settings.
			Group Owner	—	—	On <b>off*</b>	Set your machine as the Group Owner.
			Device Information	Device Name	—	—	You can see the device name of your machine.
	<p>+ Network User's Guide</p> <p>♣ Visit the Brother Solutions Center to download the Wi-Fi Direct™ Guide at <a href="http://solutions.brother.com/">http://solutions.brother.com/</a>.</p> <p> The factory settings are shown in Bold with an asterisk.</p>						

Level 1	Level 2	Level 3	Level 4	Level 5	Options	Descriptions
Network + (continued)	Wi-Fi Direct ♣ (MFC-9340CDW) (continued)	Device Information (continued)	SSID	—	—	Shows the SSID of the Group Owner.  When the machine is not connected, Touchscreen shows <b>Not Connected</b> .
			IP Address	—	—	You can see the current IP Address of your machine.
		Status Information	Status	—	G/O Active(**) Client Active Not Connected Off Wired LAN Active ** = the number of devices	You can see the current Wi-Fi Direct™ network status.
			Signal	—	Strong Medium Weak None	You can see the current Wi-Fi Direct™ network signal strength.  When your machine acts as the Group Owner, the Touchscreen always shows <b>Strong</b> .
	I/F Enable	—	—	On <b>Off*</b>	Enable or Disable the Wi-Fi Direct™ connection.	
	E-mail/IFAX (Available after IFAX is downloaded)	Mail Address	—	—	—	Enter the mail address (Up to 60 characters).
		Setup Server	SMTP	SMTP Server	Name (Up to 64 characters) IP Address [000-255]. [000-255]. [000-255]. [000-255]	Enter the SMTP server address.
					SMTP Port	25* [1-65535]

+ Network User's Guide

♣ Visit the Brother Solutions Center to download the Wi-Fi Direct™ Guide at <http://solutions.brother.com/>.





The factory settings are shown in **Bold** with an asterisk.

Level 1	Level 2	Level 3	Level 4	Level 5	Options	Descriptions
Network † (continued)	E-mail/IFAX (Available after IFAX is downloaded) (continued)	Setup Server (continued)	SMTP (continued)	Auth. for SMTP	<b>None*</b> SMTP-AUTH POP bef. SMTP	Select the Security method for E-mail notification.
				SMTP SSL/TLS	<b>None*</b> SSL TLS	Send or receive an E-mail via an E-mail server that requires secure SSL/TLS communication.
				Verify SMTPCert.	On <b>Off*</b>	Verify the SMTP Server Certificate automatically.
			POP3	POP3 Server	Name (Up to 64 characters) IP Address [000-255]. [000-255]. [000-255]. [000-255]	Enter the POP3 server address.
				POP3 Port	110* [1-65535]	Enter the POP3 port number.
				Mailbox Name	—	Enter the mail box name (Up 60 characters).
				Mailbox Password	—	Enter the password to log in to the POP3 server (Up 32 characters).
				POP3 SSL/TLS	<b>None*</b> SSL TLS	You can send or receive an E-mail via an E-mail server that requires secure SSL/TLS communication.
				Verify POP3Cert.	On <b>Off*</b>	Verify the POP3 Server Certificate automatically.
				APOP	On <b>Off*</b>	Enable or disable APOP.
Setup Mail RX	Auto Polling	Auto Polling	<b>On*</b> Off	Automatically check the POP3 server for new messages.		
† Network User's Guide						
♣ Visit the Brother Solutions Center to download the Wi-Fi Direct™ Guide at <a href="http://solutions.brother.com/">http://solutions.brother.com/</a> .						
 The factory settings are shown in Bold with an asterisk.						

Level 1	Level 2	Level 3	Level 4	Level 5	Options	Descriptions
Network † (continued)	E-mail/IFAX (Available after IFAX is downloaded) (continued)	Setup Mail RX (continued)	Auto Polling (continued)	Poll Frequency (When Auto Polling is set to On.)	1Min 3Mins 5Mins <b>10Mins*</b> 30Mins 60Mins	Set the interval for checking for new messages on the POP3 server.
			Header	—	All Subject+From+To <b>None*</b>	Select the contents of the mail header to be printed.
			Delete Error Mail	—	<b>On*</b> Off	Delete error mails automatically.
			Notification	—	On MDN <b>Off*</b>	Receive notification messages.
		Setup Mail TX	Sender Subject	—	—	Display the subject that is attached to the Internet Fax data.
			Size Limit	—	On <b>Off*</b>	Limit the size of E-mail documents.
			Notification	—	On <b>Off*</b>	Send notification messages.
		Setup Relay	Relay Broadcast	—	On <b>Off*</b>	Relay a document to another fax machine.
			Relay Domain	—	—	Register the Domain name.
			Relay Report	—	On <b>Off*</b>	Print the Relay Broadcast Report.
		Manual POP3 Receive	—	—	—	Manually checks the POP3 server for new messages.
		Fax to Server (Available after IFAX is downloaded)	Fax to Server	—	—	On <b>Off*</b>
	Prefix		—	—	—	
	Suffix		—	—	—	
	† Network User's Guide					
♣ Visit the Brother Solutions Center to download the Wi-Fi Direct™ Guide at <a href="http://solutions.brother.com/">http://solutions.brother.com/</a> .						
 The factory settings are shown in Bold with an asterisk.						



Level 1	Level 2	Level 3	Level 4	Level 5	Options	Descriptions
<b>Network</b> + (continued)	<b>Network Reset</b>	—	—	—	Yes No	Restore all network settings to the factory settings.
<p>+ Network User's Guide</p> <p>♣ Visit the Brother Solutions Center to download the Wi-Fi Direct™ Guide at <a href="http://solutions.brother.com/">http://solutions.brother.com/</a>.</p>						
 The factory settings are shown in Bold with an asterisk.						

Level 1	Level 2	Level 3	Level 4	Options	Descriptions	See Page
Print Reports	XMIT Verify	View on LCD	—	—	Display and print a Transmission Verification Report for your last transmission.	See ◆.
		Print Report	—	—		
	Address Book	—	—	—	List names and numbers stored in the Address Book.	
	Fax Journal	—	—	—	List information about your last 200 incoming and outgoing faxes. (TX means Transmit. RX means Receive.)	
	User Settings	—	—	—	List your settings.	
	Network Configuration	—	—	—	List your Network settings.	
	Drum Dot Print	—	—	—	Print the Drum Dot Check Sheet.	102
	WLAN Report (MFC-9340CDW)	—	—	—	Print the result of wireless LAN connectivity diagnosis.	See ‡.
	Caller ID history	—	—	—	Prints the caller Id list of incoming calls and faxes.	See ◆.
◆ Advanced User's Guide						
‡ Quick Setup Guide						
 The factory settings are shown in Bold with an asterisk.						

Level 1	Level 2	Level 3	Level 4	Options	Descriptions	See Page	
Machine Info.	Serial No.	—	—	—	Check the serial number of your machine.	155	
	Firmware Version	Main Version	—	—	—	Check the firmware version of your machine.	155
		Sub1 Version	—	—			
		Sub2 Version	—	—			
	Page Counter	Total	—	—	Colour Black and White	Check the number of total colour or black & white pages the machine has printed during its life.	See ◆.
		Fax/List	—	—	Colour Black and White		
		Copy	—	—	Colour Black and White		
		Print	—	—	Colour Black and White		
	Parts Life	Drum Black(BK)	—	—	—	Check the remaining life of a machine part.	
		Drum Cyan(C)	—	—	—		
		Drum Magenta(M)	—	—	—		
		Drum Yellow(Y)	—	—	—		
		Belt Unit	—	—	—		
Fuser		—	—	—			
PF kit		—	—	—			
◆ Advanced User's Guide							
	The factory settings are shown in Bold with an asterisk.						

Level 1	Level 2	Level 3	Level 4	Options	Descriptions	See Page
Initial Setup	Date & Time	Date	—	—	Put the date and time on the Touchscreen and in the headings of faxes you send.	See ‡.
		Time	—	—		
		Time Zone	—	UTCXXX:XX	Set the time zone for your country.	
	Station ID	—	—	Fax Tel Name	Set up your name and fax number to appear on each page you fax.	
	Tone/Pulse	—	—	<b>Tone*</b> Pulse	Choose the dialling mode.	
	Dial Tone	—	—	Detection <b>No Detection*</b>	You can shorten the dial tone detect pause.	144
	Dial Prefix	—	—	On <b>Off*</b>	Sets a prefix number that will always be added before the fax number every time you dial.	See ◆.
	Compatibility	—	—	<b>High*</b> Normal Basic(for VoIP)	Adjust the equalization for transmission difficulties.  VoIP service providers offer fax support using various standards. If you regularly experience fax transmission errors, choose Basic(for VoIP).	144
	Reset	Network	—	Yes No	Restore all network settings to the factory settings.	156
		Address Book & Fax	—	Yes No	Restore all stored phone numbers and fax settings.	
All Settings		—	Yes No	Restore all the machine settings to the factory settings.		
Local Language	—	—	中文* English	Allows you to change the Touchscreen language.	See ‡.	
◆ Advanced User's Guide						
‡ Quick Setup Guide						
 The factory settings are shown in Bold with an asterisk.						

# Features Tables



## Fax (When Fax Preview is Off)

Level 1	Level 2	Level 3	Options	Descriptions	See Page
Redial (Pause)	—	—	—	Redial the last number called. When you are entering a fax or telephone number on the Touchpanel, Redial changes to Pause on the Touchscreen. Press Pause when you need a delay while dialing numbers, such as access codes and credit card numbers. You can also store a pause when you set up addresses.	—
Hook	—	—	—	Press before dialing when you want to listen to make sure a fax machine has answered, and then press Fax Start.	—
Address Book	 (Search)	—	—	Search within the Address Book.	53
	Edit	—	Add New Address	Store Address Book numbers, so you can dial by pressing Address Book on the Touchscreen (and Fax Start).	54
			Setup Groups	Set up Group numbers for Broadcasting.	See ♦.
			Change	Change Address Book numbers.	55 and
			Delete	Delete Address Book numbers.	see ♦.
—	<b>Apply</b>	—	Start sending a fax using the address book.	—	

♦ Advanced User's Guide



The factory settings are shown in Bold with an asterisk.

Level 1	Level 2	Level 3	Options	Descriptions	See Page
Call History	Outgoing Call	<b>Edit</b>	Add to Address Book Delete	Choose a number from the Outgoing Call history and then send a fax to it, add it to Address Book, or delete it.	See <b>◆</b> .
		<b>Apply</b>	—		
	Caller ID history	<b>Edit</b>	Add to Address Book Delete	Choose a number from the Caller ID history and then add it to Address Book, or delete it.	
Fax Start	—	—	—	Send a fax.	—
Options	Fax Resolution	—	<b>Standard*</b> Fine S.Fine Photo	Set the resolution for outgoing faxes.	See <b>◆</b> .
	2-sided Fax (MFC-9340CDW)	—	<b>Off*</b> 2-sided Scan: Long Edge 2-sided Scan: Short Edge	Set the 2-sided scanning format.	
	Contrast	—	<b>Auto*</b> Light Dark	Change the lightness or darkness of faxes you send.	
	Broadcasting	<b>Add Number</b>	Add Number	Send the same fax message to more than one fax number.	
			Add from Address book		
			Search in Address book		
	Delayed Fax	<b>Delayed Fax</b>	On <b>Off*</b>	Set the time of day that delayed faxes will be sent.	
		<b>Set Time</b>	—		
Real Time TX	—	On <b>Off*</b>	Send a fax without using the memory.		
Polled TX	—	Standard Secure <b>off*</b>	Set up your machine with a document to be retrieved by another fax machine.		

◆ Advanced User's Guide



The factory settings are shown in Bold with an asterisk.

Level 1	Level 2	Level 3	Options	Descriptions	See Page
Options (continued)	Coverpage Setup	Coverpage Setup	On <b>Off*</b>	Automatically send a cover page you programmed.	See <b>◆</b> .
		Coverpage Note	1.Comment Off 2.Please Call 3.Urgent 4.Confidential 5. 6.		
		Total Pages	—		
	Polling RX	—	Standard Secure Timer <b>Off*</b>	Set up your machine to poll another fax machine.	
	Overseas Mode	—	On <b>Off*</b>	If you are having difficulty sending faxes overseas, set this to On.	
	Glass Scan Size	—	Letter <b>A4*</b>	To fax a Letter size document, you must change the Glass Scan Size setting.	37
	Set New Default	—	Yes No	Save your fax settings as the default settings.	See <b>◆</b> .
Factory Reset	—	Yes No	Restore all the fax settings you changed back to the factory settings.		
Save as Shortcut	—	—	—	Register the current settings as a shortcut.	
◆ Advanced User's Guide					
 The factory settings are shown in Bold with an asterisk.					



## Fax (When Fax Preview is On)

Level 1	Level 2	Level 3	Options	Descriptions	See Page
<b>Sending Faxes</b>	See <i>Fax (When Fax Preview is Off)</i> on page 179.				
<b>Received Faxes</b>	<b>Print/Delete</b>	<b>Print All(New Faxes)</b>	—	Print the new received faxes.	44
		<b>Print All(Old Faxes)</b>	—	Print the old received faxes.	
		<b>Delete All(New Faxes)</b>	—	Delete the new received faxes.	44
		<b>Delete All(Old Faxes)</b>	—	Delete the old received faxes.	
<b>Address Book</b>	See <i>Fax (When Fax Preview is Off)</i> on page 179.				
<b>Call History</b>	See <i>Fax (When Fax Preview is Off)</i> on page 179.				
◆ Advanced User's Guide					
 The factory settings are shown in Bold with an asterisk.					





## Copy



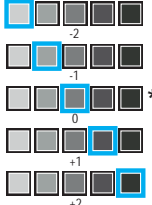
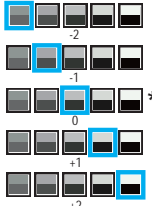

Level 1	Level 2	Level 3	Options 1	Options 2	Descriptions	See Page
<b>Mono Start</b>	—	—	—	—	Lets you make a monochrome copy.	—
<b>Colour Start</b>	—	—	—	—	Lets you make a colour copy.	
<b>Receipt</b> <b>Normal</b> <b>2in1 (ID)</b> <b>2in1</b> <b>2-sided(1⇒2)</b> <b>2-sided(2⇒2)</b> <b>(MFC-9340CDW)</b> <b>Paper Save</b>	—	—	—	—	Choose the desired settings from the preset items.	57
<b>Options</b>	<b>Quality</b>	—	<b>Auto*</b> Text Photo Receipt	—	Choose the Copy resolution for your type of document.	See <b>◆</b> .
◆ Advanced User's Guide						
 The factory settings are shown in Bold with an asterisk.						

Level 1	Level 2	Level 3	Options 1	Options 2	Descriptions	See Page
Options (continued)	Enlarge/Reduce	—	<b>100%*</b>	—	—	See ◆.
			Enlarge	200% 141% A5⇒A4 104% EXE⇒LTR	Choose an enlargement ratio for the next copy.	
			Reduce	97% LTR⇒A4 94% A4⇒LTR 91% Full Page 85% LTR⇒EXE 83% LGL⇒A4 78% LGL⇒LTR 70% A4⇒A5 50%	Choose a reduction ratio for the next copy.	
			Custom (25-400%)	—	You can choose the enlargement or reduction ratio for the next copy.	
	Density	—		—	Adjust the Density for copies.	
Contrast	—		—	Adjust the contrast for copies.		
Stack/Sort	—	<b>Stack*</b> Sort	—	Choose to stack or sort multiple copies.		
Page Layout	—	<b>Off(1in1)*</b> 2in1(P) 2in1(L) 2in1(ID) 4in1(P) 4in1(L)	—	Make N in 1 and 2 in 1 ID copies.		

◆ Advanced User's Guide

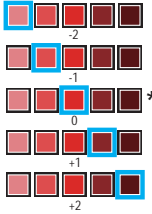

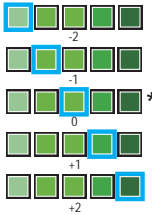
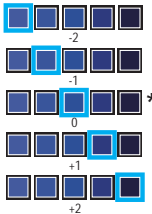
The factory settings are shown in Bold with an asterisk.

Level 1	Level 2	Level 3	Options 1	Options 2	Descriptions	See Page
Options (continued)	Colour Adjust	Red		—	Adjust the red colour for copies.	See  .
		Green		—	Adjust the green colour for copies.	
		Blue		—	Adjust the blue colour for copies.	
	2-sided Copy (MFC-9140CDN)	—	<b>Off*</b> 1-sided⇒2-sided Long Edge Flip 1-sided⇒2-sided Short Edge Flip	—	Enable or disable 2-sided copying and choose long edge or short edge.	
	2-sided Copy (MFC-9340CDW)	—	<b>Off*</b> 2-sided⇒2-sided 1-sided⇒2-sided Long Edge Flip 2-sided⇒1-sided Long Edge Flip 1-sided⇒2-sided Short Edge Flip 2-sided⇒1-sided Short Edge Flip	—		
◆ Advanced User's Guide						
 The factory settings are shown in Bold with an asterisk.						

Level 1	Level 2	Level 3	Options 1	Options 2	Descriptions	See Page
Options (continued)	—	—	<b>2-sided Copy Page Layout</b> (MFC-9340CDW)	<b>LongEdge</b> ⇒ <b>LongEdge*</b> LongEdge⇒ ShortEdge ShortEdge⇒ LongEdge ShortEdge⇒ ShortEdge	Choose a page layout option when you make 2-sided N in 1 copies from a 2-sided document.	See ◆.
	<b>Advanced Settings</b>	—	<b>Off*</b> Remove Background Colour	— Low <b>Medium*</b> High	Change the amount of background colour that is removed.	
	<b>Save as Shortcut</b>	—	—	—	Add the current settings as a shortcut.	
◆ Advanced User's Guide						
 The factory settings are shown in Bold with an asterisk.						



## Scan

Level 1	Level 2	Level 3	Level 4	Options	Descriptions	See Page
to OCR	(PC Select)	<b>Options</b>	See <i>Options (to OCR)</i> on page 189.			See <input type="checkbox"/> .
		<b>Save as Shortcut</b>	—	—	Add the current settings as a shortcut.	
		<b>Start</b>	—	—	Start scanning.	
to File	(PC Select)	<b>Options</b>	See <i>Options (to File, to Image and to E-mail)</i> on page 190.			
		<b>Save as Shortcut</b>	—	—	Add the current settings as a shortcut.	
		<b>Start</b>	—	—	Start scanning.	
to Image	(PC Select)	<b>Options</b>	See <i>Options (to File, to Image and to E-mail)</i> on page 190.			
		<b>Save as Shortcut</b>	—	—	Add the current settings as a shortcut.	
		<b>Start</b>	—	—	Start scanning.	
to USB (MFC-9340CDW)	<b>Options</b>	See <i>Options (to USB)</i> on page 191.				
	<b>Save as Shortcut</b>	—	—	—	Add the current settings as a shortcut.	
	<b>Start</b>	—	—	—	Start scanning.	
to E-mail	(PC Select)	<b>Options</b>	See <i>Options (to File, to Image and to E-mail)</i> on page 190.			
		<b>Save as Shortcut</b>	—	—	Add the current settings as a shortcut.	
		<b>Start</b>	—	—	Start scanning.	
to E-mail Server (Download only)	<b>Address Book</b>	—	—	—	Choose the address of the recipient from the address book.	
		—	—	—	Manually enter the address of the recipient.	
	<b>OK</b>	<b>Options</b>	See <i>Options (to E-mail Server)</i> on page 193.			
		<b>Save as Shortcut</b>	—	—	Add the current settings as a shortcut.	
		<b>Start</b>	—	—	Start scanning.	

 Software User's Guide



The factory settings are shown in Bold with an asterisk.

Level 1	Level 2	Level 3	Level 4	Options	Descriptions	See Page
to FTP	(Profile name)	<b>Options</b>	See <i>Options (to FTP and to Network)</i> on page 195.		Add the current settings as a shortcut.	See <input type="checkbox"/> .
		<b>Save as Shortcut</b>	—	—		
		<b>Start</b>	—	—		
to Network	(Profile name)	<b>Options</b>	See <i>Options (to FTP and to Network)</i> on page 195.		Add the current settings as a shortcut.	
		<b>Save as Shortcut</b>	—	—		
		<b>Start</b>	—	—		
WS Scan (Appears when you install a Web Services Scan, which is displayed in your computer's Network explorer.)	<b>Scan</b>	—	—	—	Scan data using the Web Service protocol.	
	<b>Scan for E-mail</b>	—	—	—		
	<b>Scan for Fax</b>	—	—	—		
	<b>Scan for Print</b>	—	—	—		
<input type="checkbox"/> Software User's Guide						
 The factory settings are shown in Bold with an asterisk.						

## Options (to OCR)

Level 1	Level 2	Options	Descriptions	See Page
Options	<b>2-sided Scan</b> (MFC-9340CDW)	<b>Off*</b> 2-sided Scan: Long Edge 2-sided Scan: Short Edge	Choose the 2-sided scan mode.	See <input type="checkbox"/> .
	<b>Set with Touch Panel</b>	<b>Off(Set with Computer)*</b> On	To change settings using the Touchscreen, choose On.	
	<b>Scan Type</b>	Colour Grey <b>Black and White*</b>	Choose the scan type for your document.	
	<b>Resolution</b>	100 dpi <b>200 dpi*</b> 300 dpi 600 dpi	Choose the scan resolution for your document.	
	<b>File Type</b>	<b>Text*</b> HTML RTF	Choose the file format for your document	
	<b>Scan Size</b>	<b>A4*</b> Letter Legal	Choose the scan size for your document.	
<input type="checkbox"/> Software User's Guide				
 The factory settings are shown in Bold with an asterisk.				

## Options (to File, to Image and to E-mail)

Level 1	Level 2	Options	Descriptions	See Page
Options	2-sided Scan (MFC-9340CDW)	<b>Off*</b> 2-sided Scan: Long Edge 2-sided Scan: Short Edge	Choose the 2-sided scan mode.	See <input type="checkbox"/> .
	Set with Touch Panel	<b>Off(Set with Computer)*</b> On	To change settings using the Touchscreen, choose On.	
	Scan Type	<b>Colour*</b> Grey Black and White	Choose the scan type for your document.	
	Resolution	100 dpi <b>200 dpi*</b> 300 dpi 600 dpi	Choose the scan resolution for your document.	
	File Type	(When you select Colour or Grey in Scan Type) <b>PDF*</b> JPEG  (When you select Black and White in Scan Type) <b>PDF*</b> TIFF	Choose the file format for your document.	
	Scan Size	<b>A4*</b> Letter Legal	Choose the scan size for your document.	
	Remove Background Colour	<b>Off*</b> Low Medium High	Change the amount of background colour that is removed.  This function is not available for Black and White scanning.	
<input type="checkbox"/> Software User's Guide				
 The factory settings are shown in Bold with an asterisk.				



## Options (to USB)

Level 1	Level 2	Options	Descriptions	See Page
Options	2-sided Scan	Off* 2-sided Scan: Long Edge 2-sided Scan: Short Edge	Choose the 2-sided scan mode.	See <input type="checkbox"/> .
	Scan Type	Colour* Grey Black and White	Choose the scan type for your document.	
	Resolution	(When you select Colour in Scan Type) 100 dpi <b>200 dpi*</b> 300 dpi 600 dpi Auto  (When you select Grey in Scan Type) 100 dpi <b>200 dpi*</b> 300 dpi Auto  (When you select Black and White in Scan Type) <b>200 dpi*</b> 300 dpi 200x100	Choose the scan resolution for your document.	
<input type="checkbox"/> Software User's Guide				
 The factory settings are shown in Bold with an asterisk.				

Level 1	Level 2	Options	Descriptions	See Page
Options (continued)	<b>File Type</b>	(When you select <b>Colour</b> or <b>Grey</b> in Scan Type)  <b>PDF*</b> JPEG PDF/A Secure PDF Signed PDF XPS  (When you select <b>Black</b> and <b>White</b> in Scan Type) <b>PDF*</b> PDF/A Secure PDF Signed PDF TIFF	Choose the file format for your document.	See <input type="checkbox"/> .
	<b>Glass Scan Size</b>	<b>A4*</b> Letter	To scan a Letter sized document, you must change the Glass Scan Size setting.	
	<b>File Name</b>	—	Enter a file name for the scanned data.	
	<b>File Size</b>	Small <b>Medium*</b> Large	Choose the file size for colour or greyscale scanning.	
	<b>Remove Background Colour</b>	<b>Off*</b> Low Medium High	Change the amount of background colour that is removed.	
	<b>Set New Default</b>	Yes No	Save your scan settings as the default settings.	
	<b>Factory Reset</b>	Yes No	Restore all the scan settings you changed back to the factory settings.	
<input type="checkbox"/> Software User's Guide				
 The factory settings are shown in Bold with an asterisk.				

## Options (to E-mail Server)

Level 1	Level 2	Options	Descriptions	See Page
Options	<b>2-sided Scan</b> (MFC-9340CDW)	<b>Off*</b> 2-sided Scan: Long Edge 2-sided Scan: Short Edge	Choose the 2-sided scan mode.	See <input type="checkbox"/> .
	<b>Scan Type</b>	<b>Colour*</b> Grey Black and White	Choose the scan type for your document.	
	<b>Resolution</b>	(When you select <b>Colour</b> in Scan Type) 100 dpi <b>200 dpi*</b> 300 dpi 600 dpi Auto  (When you select <b>Grey</b> in Scan Type) 100 dpi <b>200 dpi*</b> 300 dpi Auto  (When you select <b>Black and White</b> in Scan Type) <b>200 dpi*</b> 300 dpi 200x100	Choose the scan resolution for your document.	
<input type="checkbox"/> Software User's Guide				
 The factory settings are shown in Bold with an asterisk.				

Level 1	Level 2	Options	Descriptions	See Page
Options (continued)	File Type	(When you select Colour or Grey in Scan Type)  <b>PDF*</b> JPEG PDF/A Secure PDF Signed PDF XPS  (When you select Black and White in Scan Type) <b>PDF*</b> PDF/A Secure PDF Signed PDF TIFF	Choose the file format for your document.	See <input type="checkbox"/> .
	Glass Scan Size	<b>A4*</b> Letter	To scan a Letter sized document, you must change the Glass Scan Size setting.	
	File Size	Small <b>Medium*</b> Large	Choose the file size for colour or greyscale scanning.	
	Set New Default	Yes No	Save your scan settings as the default settings.	
	Factory Reset	Yes No	Restore all the scan settings you changed back to the factory settings.	

Software User's Guide



The factory settings are shown in Bold with an asterisk.

## Options (to FTP and to Network)

Level 1	Level 2	Options	Descriptions	See Page
Options	<b>2-sided Scan</b> (MFC-9340CDW)	<b>Off*</b> 2-sided Scan: Long Edge 2-sided Scan: Short Edge	Choose the 2-sided scan mode.	See <input type="checkbox"/> .
	<b>Scan Type</b>	<b>Colour*</b> Grey Black and White	Choose the scan type for your document.	
	<b>Resolution</b>	(When you select <b>Colour</b> in Scan Type) 100 dpi <b>200 dpi*</b> 300 dpi 600 dpi Auto  (When you select <b>Grey</b> in Scan Type) 100 dpi <b>200 dpi*</b> 300 dpi Auto  (When you select <b>Black and White</b> in Scan Type) <b>200 dpi*</b> 300 dpi 200x100	Choose the scan resolution and file format for your document.	
<input type="checkbox"/> Software User's Guide				
 The factory settings are shown in Bold with an asterisk.				

Level 1	Level 2	Options	Descriptions	See Page
Options (continued)	File Type	(When you select Colour or Grey in Scan Type)  <b>PDF*</b>  JPEG  PDF/A  Secure PDF  Signed PDF  XPS  (When you select Black and White in Scan Type)  <b>PDF*</b>  PDF/A  Secure PDF  Signed PDF  TIFF	Choose the scan resolution and file format for your document.	See <input type="checkbox"/> .
	Glass Scan Size	<b>A4*</b>  Letter	To scan a Letter sized document, you must change the Glass Scan Size setting.	
	File Name	<b>BRNXXXXXXXXXX*</b>  Estimate  Report  Order sheet  Contract sheet  Check  Receipt  <Manual>	Choose preset file names. If you choose <Manual>, you can name the file as you like.  "XXXXXXXXXX" is your machine's MAC Address/Ethernet Address.	
	File Size	Small  <b>Medium*</b>  Large	Choose the file size for colour or greyscale scanning.	
	Remove Background Colour	<b>Off*</b>  Low  Medium  High	Change the amount of background colour that is removed.	
	User Name	—	Enter the user name.	
<input type="checkbox"/> Software User's Guide				
 The factory settings are shown in Bold with an asterisk.				

## Direct Print (MFC-9340CDW)

Level 1	Level 2	Level 3	Level 4	Options	Descriptions	Page
Direct Print	(Select File)	Print Settings (No. of Prints (001-999))	Paper Type	Thin <b>Plain Paper*</b> Thick Thicker Recycled Paper Glossy	Set the print media type when printing directly from the USB flash memory drive.	60
			Paper Size	<b>A4*</b> Letter Legal EXE A5 A5 L A6 B5 Folio 16K(195x270mm) 16K(184x260mm) 16K(197x273mm)	Set the paper size when printing directly from the USB flash memory drive.	60
			Multiple Page	<b>1in1*</b> 2in1 4in1 9in1 16in1 25in1 1 in 2x2 pages 1 in 3x3 pages 1 in 4x4 pages 1 in 5x5 pages	Set the page layout when printing multiple pages directly from the USB Flash memory drive.	60
			Orientation	<b>Portrait*</b> Landscape	Set the page orientation when printing directly from the USB Flash memory drive.	60
			2-sided	<b>Off*</b> Long Edge Short Edge	Choose the 2-sided print format when printing directly from the USB Flash memory drive.	60
 The factory settings are shown in Bold with an asterisk.						

Level 1	Level 2	Level 3	Level 4	Options	Descriptions	Page
Direct Print (continued)	(Select File)	Print Settings (No. of Prints (001-999)) (continued)	Collate	On* Off	Enable or disable page collation when printing directly from the USB Flash memory drive.	60
			Print Quality	Normal* Fine	Set the print quality option when printing directly from the USB Flash memory drive.	60
			PDF Option	Document* Document&Markup Document&Stamps	Set the USB direct print setting whether to print comments (Markup) or stamps in the PDF file along with the text.	60
Index Print	—	—	—	—	Print a thumbnail page.	60
Default Settings	Paper Type	—	—	Thin Plain Paper* Thick Thicker Recycled Paper Glossy	Set the default media type when printing directly from the USB flash memory drive.	62
	Paper Size	—	—	A4* Letter Legal EXE A5 A5 L A6 B5 Folio 16K(195x270mm) 16K(184x260mm) 16K(197x273mm)	Set the default paper size when printing directly from the USB flash memory drive.	62



The factory settings are shown in Bold with an asterisk.





Level 1	Level 2	Level 3	Level 4	Options	Descriptions	Page
Default Settings (continued)	Multiple Page	—	—	<b>1in1*</b> 2in1 4in1 9in1 16in1 25in1 1 in 2x2 pages 1 in 3x3 pages 1 in 4x4 pages 1 in 5x5 pages	Set the default page style when printing multiple pages directly from the USB Flash memory drive.	62
	Orientation	—	—	<b>Portrait*</b> Landscape	Set the default page orientation when printing directly from the USB Flash memory drive.	62
	Collate	—	—	<b>On*</b> Off	Enable or disable the default page collation when printing directly from the USB Flash memory drive.	62
	Print Quality	—	—	<b>Normal*</b> Fine	Set the default print quality option when printing directly from the USB Flash memory drive.	62
	PDF Option	—	—	<b>Document*</b> Document&Markup Document&Stamps	Set the default USB direct print setting to print comments (Markup) or stamps in the PDF file along with the text.	62
	Index Print	—	—	<b>Simple*</b> Details	Set the default index print option to simple format or details.	62



The factory settings are shown in Bold with an asterisk.



## Toner



Level 1	Level 2	Level 3	Options	Descriptions	See Page
	<b>Toner Life</b>	—	—	View the approximate remaining toner life for each colour.	See <b>◆</b> .
	<b>Test Print</b>	—	—	Print the Test Print page.	
	<b>Calibration</b>	<b>Calibrate</b>	Yes	Adjust the colour density or return the colour calibration to the factory settings.	109
			No		
	<b>Auto Regist.</b>	—	Yes	Adjust the print position of each colour automatically.	110
No					
◆ Software User's Guide					
 The factory settings are shown in Bold with an asterisk.					



## Wi-Fi Setup (MFC-9340CDW)

### NOTE

After Wi-Fi is set up, you cannot change the settings from your Home screen. Change the settings for Wi-Fi in the Settings screen.

Level 1	Level 2	Level 3	Options	Descriptions	See Page
	<b>Setup Wizard</b>	—	—	Configure your internal print server.	See <b>‡</b> .
	<b>Setup with PC</b>	—	—	Configure the Wi-Fi settings using a computer.	
	<b>WPS/AOSS</b>	—	—	Easily configure your wireless network settings using the one-button push method.	
	<b>WPS w/ PIN Code</b>	—	—	Easily configure your wireless network settings using WPS with a PIN code.	
‡ Software User's Guide					
 The factory settings are shown in Bold with an asterisk.					

 **Shortcut**

Level 1	Level 2	Level 3	Level 4	Options	Descriptions	Page
Add Shortcut	Copy	<b>Receipt</b>	—	See <i>Options</i> on page 183.	Choose the desired settings from the preset items.	15
		<b>Normal</b>	—			
		<b>2in1 (ID)</b>	—			
		<b>2in1</b>	—			
		<b>2-sided(1→2)</b>	—			
		<b>2-sided(2→2)</b> (MFC-9340CDW)	—			
		<b>Paper Save</b>	—			
	Fax (Options)	<b>Fax Resolution</b>	—	Standard Fine S.Fine Photo	Set the resolution for outgoing faxes.	15
		<b>2-sided Fax</b> (MFC-9340CDW)	—	Off 2-sided Scan: Long Edge 2-sided Scan: Short Edge	Choose the 2-sided fax scan mode.	15
		<b>Contrast</b>	—	Auto Light Dark	Change the lightness or darkness of faxes you send.	15
<b>Broadcasting</b>		—	Add Number (Options) Add Number Add from Address book Search in Address book	Send the same fax message to more than one fax number.	15	
<b>Real Time TX</b>		—	On Off	Send a fax without using the memory.	15	
 The factory settings are shown in Bold with an asterisk.						

Level 1	Level 2	Level 3	Level 4	Options	Descriptions	Page
Add Shortcut (continued)	Fax (Options) (continued)	Coverpage Setup	Coverpage Setup	On Off	Automatically send a cover page you programmed.	15
			Coverpage Note	1.Comment Off 2.Please Call 3.Urgent 4.Confidential 5. 6.		
			Total Pages	—		
		Overseas Mode	— On Off	If you are having difficulty sending faxes overseas, set this to On.		
		Grass Scan Size	—	Letter A4	Adjust the scan area of the scanner glass to the size of the document.	15
	Scan	to File	—	PC Select	Scan a black & white or a colour document into your computer.	16
		to OCR	—	PC Select	Convert your text document to an editable text file.	16
		to Image	—	PC Select	Scan a colour picture into your graphics application.	16
		to USB (MFC-9340CDW)	—	2-sided Scan Scan type Resolution File Type Glass Scan Size File Name File Size Remove Background Colour	Scan documents into a USB Flash memory drive.	16
		to E-mail	—	PC Select	Scan a black & white or a colour document into your E-mail application.	16



The factory settings are shown in Bold with an asterisk.

Level 1	Level 2	Level 3	Level 4	Options	Descriptions	Page
Add Shortcut (continued)	Scan (continued)	to E-mail Server	—	Address  2-sided Scan (MFC-9340CDW)  Scan Type  Resolution  File Type  Glass Scan Size  File Size	Scan a black & white or a colour document into your E-mail Server.	16
		to Network	—	Profile Name	Send scanned data to a CIFS server on your local network or on the Internet.	16
		to FTP	—	Profile Name	Send scanned data via FTP.	16
 The factory settings are shown in Bold with an asterisk.						

## Entering text

When you need to enter text into the machine the keyboard will appear on the Touchscreen.

Press  to cycle among letters, numbers and special characters.

Press  to cycle between upper and lower case letters.





### Inserting spaces

To enter a space, press `space` or .

### Making corrections

If you entered an incorrect character and want to change it, use the arrow buttons to move the cursor under the incorrect character. Press , and then enter the correct character. You can also insert letters by moving the cursor and entering a character.

If the screen does not show , press  repeatedly until you have erased the incorrect character. Enter the correct characters.

### NOTE

---

- The characters available may differ depending on your country.
  - The keyboard layout may differ depending on the function you are setting.
-

## Entering Chinese characters

You can use Chinese characters for some of the text input to your machine if you select "中文" in the Local Language setting (see Quick Setup Guide: *Set your language*). Simplified Chinese can be converted from Pinyin entry.



### NOTE

---

If  appears on the Touchscreen, conversion of Pinyin to Chinese characters is available.

---

For example, if you want to enter "Good 公司", follow the procedures:

- 1 Press G, o, o, d, and then press .
- 2 Press g, o, n, g, s, i, and then press .  
Some candidate Chinese characters and phrases will appear on the Touchscreen.
- 3 Swipe up or down, or press ▲ or ▼ to display "公司".
- 4 Press "公司".
- 5 Press OK to complete.

# D

# Specifications

## General

Model	MFC-9140CDN	MFC-9340CDW
Printer Type	LED	
Print Method	Electrophotographic LED Printer	
Memory Capacity	192 MB	256 MB
LCD (liquid crystal display)	3.7 in. (93.4 mm) TFT Colour Touchscreen LCD <sup>1</sup> and Touchpanel	
Power Source	220 - 240 V AC 50/60 Hz	
Power Consumption <sup>2</sup> (Average)	Peak	Approx. 1200 W
	Printing	Approx. 375 W at 25 °C
	Copying	Approx. 380 W at 25 °C
	Ready	Approx. 70 W at 25 °C
	Sleep	Approx. 7.5 W
	Deep Sleep	Approx. 1.8 W
	Power Off <sup>3 4</sup>	Approx. 0.05 W
Dimensions		
Weights (with consumables)	23.2 kg	23.5 kg

<sup>1</sup> Measured diagonally

<sup>2</sup> USB connections to PC

<sup>3</sup> Measured according to IEC 62301 Edition 2.0

<sup>4</sup> Power consumption varies slightly depending on the usage environment or part wear.



Model		MFC-9140CDN	MFC-9340CDW
Noise Level	Sound Pressure	Printing	LPAM = 53.0 dB (A)
		Ready	LPAM = 33 dB (A)
	Sound Power	Printing (Colour)	LWAd = 6.39 B (A)
		Printing (Monochrome)	LWAd = 6.42 B (A)
		Ready	LWAd = 4.44 B (A)
Temperature		Operating	10 to 32.5 °C <sup>1</sup>
		Storage	0 to 40 °C
Humidity		Operating	20 to 80% (without condensation)
		Storage	10 to 90% (without condensation)
ADF (automatic document feeder)		Up to 35 pages For best results we recommend: Temperature: 20 to 30 °C Humidity: 50% to 70% Paper: 80 g/m <sup>2</sup>	

<sup>1</sup> To ensure the high print quality, the maximum ambient temperature we recommend is 32.5 °C. The maximum ambient temperature to safely use this machine is 35 °C.

## Document Size

Model		MFC-9140CDN	MFC-9340CDW
<b>Document Size (1-sided)</b>	ADF Width	147.3 to 215.9 mm	
	ADF Length	147.3 to 355.6 mm	
	Scanner Glass Width	Max. 215.9 mm	
	Scanner Glass Length	Max. 300.0 mm	
<b>Document Size (2-sided)</b>	ADF Width	—	147.3 to 215.9 mm
	ADF Length	—	147.3 to 355.6 mm

## Print media

Model		MFC-9140CDN	MFC-9340CDW
<b>Paper Input</b>	Paper Tray	Paper Type	Plain Paper, Thin Paper, Recycled Paper
		Paper Size	A4, Letter, B5 (JIS), A5, A5 (Long Edge), A6, Executive, Legal, Folio
		Paper Weight	60 to 105 g/m <sup>2</sup>
		Maximum Paper Capacity	Up to 250 sheets of 80 g/m <sup>2</sup> Plain Paper
	Manual Feed Slot	Paper Type	Plain Paper, Thin Paper, Thick Paper, Thicker Paper, Recycled Paper, Bond Paper, Label, Envelope, Env.Thin, Env.Thick, Glossy Paper
		Paper Size	Width: 76.2 to 215.9 mm Length: 116.0 to 355.6 mm
		Paper Weight	60 to 163 g/m <sup>2</sup>
		Maximum Paper Capacity	One sheet at a time
<b>Paper Output</b> <sup>1</sup>	Face-Down Output Tray	Up to 100 sheets of 80 g/m <sup>2</sup> Plain paper (face-down delivery to the face-down output paper tray)	
	Face-Up Output Tray	One sheet (face-up delivery to the face-up output tray)	
<b>2-sided</b>	Automatic 2-sided Printing	Paper Type	Plain Paper, Thin Paper, Recycled Paper
		Paper Size	A4
		Paper Weight	60 to 105 g/m <sup>2</sup>

<sup>1</sup> For labels, we recommend removing printed pages from the output paper tray immediately after they exit the machine to avoid the possibility of smudging.

# Fax

Model		MFC-9140CDN	MFC-9340CDW
<b>Compatibility</b>		ITU-T Super Group 3	
<b>Coding System</b>		MH/MR/MMR/JBIG	
<b>Modem Speed</b>		33,600 bps (with Automatic Fallback)	
<b>2-sided Print Receiving</b>		Yes	
<b>Automatic 2-sided Sending</b>		—	Yes (from ADF)
<b>Scanning Width</b>		Max. 208 mm	
<b>Printing Width</b>		Max. 208 mm	
<b>Greyscale</b>		8 bit/256 levels	
<b>Resolution</b>	Horizontal	8 dot/mm	
	Vertical	Standard: 3.85 line/mm	
		Fine: 7.7 line/mm	
		Photo: 7.7 line/mm	
		Superfine: 15.4 line/mm	
<b>Address Book</b>		200 names	
<b>Groups</b>		Up to 20	
<b>Broadcasting</b>		250 (200 Address Book/50 Manual Dial)	
<b>Automatic Redial</b>		3 times at 5 minute intervals	
<b>Memory Transmission</b>		Up to 500 <sup>1</sup> pages	
<b>Out of Paper Reception</b>		Up to 500 <sup>1</sup> pages	

<sup>1</sup> 'Pages' refers to the 'ITU-T Test Chart #1' (a typical business letter, Standard resolution, JBIG code). Specifications and printed materials are subject to change without prior notice.

# Copy

Model		MFC-9140CDN	MFC-9340CDW
Copy Width		Max. 210 mm	
Automatic 2-sided Copy		—	Yes (from ADF)
Multiple Copies		Stacks or Sorts up to 99 pages	
Reduce/Enlarge		25% to 400% (in increments of 1%)	
Resolution		Up to 600 × 600 dpi	
First Copy Out Time <sup>1</sup>	Monochrome	Less than 19 seconds at 23 °C / 230 V	
	Colour	Less than 22 seconds at 23 °C / 230 V	

<sup>1</sup> From Ready mode and standard tray

# Scanner

Model		MFC-9140CDN	MFC-9340CDW
<b>Colour / Mono</b>		Yes / Yes	
<b>TWAIN Compliant</b>		Yes (Windows® XP/ Windows Vista® / Windows® 7 / Windows® 8 Mac OS X v10.6.8 / 10.7.x / 10.8.x <sup>1</sup> )	
<b>WIA Compliant</b>		Yes (Windows® XP / Windows Vista® / Windows® 7 / Windows® 8)	
<b>ICA Compliant</b>		Yes (Mac OS X v10.6.8 / 10.7.x / 10.8.x)	
<b>Colour Depth</b>	Colour	48 bit colour processing (Input) 24 bit colour processing (Output)	
	Greyscale	16 bit colour processing (Input) 8 bit colour processing (Output)	
<b>Resolution</b>		Up to 19200 × 19200 dpi (interpolated) <sup>2</sup> Up to 1200 × 2400 dpi (optical) <sup>2</sup> (from Scanner Glass) Up to 1200 × 600 dpi (optical) <sup>2</sup> (from ADF)	
<b>Scanning Width</b>		Max. 210 mm	
<b>Automatic 2-sided Scanning</b>		—	Yes (from ADF)

<sup>1</sup> For the latest driver updates for the version of OS X you are using, visit us at <http://solutions.brother.com/>.

<sup>2</sup> Maximum 1200 × 1200 dpi scanning with the WIA driver in Windows® XP, Windows Vista®, Windows® 7 and Windows® 8 (resolution up to 19200 × 19200 dpi can be selected by using the scanner utility)

# Printer

Model		MFC-9140CDN	MFC-9340CDW
<b>Automatic 2-sided Print</b>		Yes	
<b>Emulations</b>		PCL6, BR-Script3 (PostScript® 3™)	
<b>Resolution</b>		600 dpi × 600 dpi	
<b>Print Speed (2-sided)</b>	Monochrome	Up to 7 sides/minute (Up to 3.5 sheets/minute) (A4 size) <sup>1</sup>	
	Colour	Up to 7 sides/minute (Up to 3.5 sheets/minute) (A4 size) <sup>1</sup>	
<b>Print Speed</b>	Monochrome	Up to 22 pages/minute (A4 size) <sup>1</sup>	
	Colour	Up to 22 pages/minute (A4 size) <sup>1</sup>	
<b>First Print Time</b> <sup>2</sup>	Monochrome	Less than 16 seconds at 23 °C / 230 V	
	Colour	Less than 16 seconds at 23 °C / 230 V	

<sup>1</sup> The print speed may vary depending on the type of document you print.

<sup>2</sup> From Ready mode and standard tray

# Interfaces

Model	MFC-9140CDN	MFC-9340CDW
<b>USB</b>	Hi-Speed USB 2.0 <sup>1 2</sup> It is recommended you use a USB 2.0 cable (Type A/B) that is no more than 2.0 metres long.	
<b>Ethernet</b> <sup>3</sup>	10BASE-T / 100BASE-TX Use a straight-through Category 5 (or greater) twisted-pair cable.	
<b>Wireless LAN</b> <sup>3</sup>	—	IEEE 802.11b/g/n (Infrastructure mode/Ad-hoc mode) IEEE 802.11g/n (Wi-Fi Direct™)

<sup>1</sup> Your machine has a Hi-Speed USB 2.0 interface. The machine can also be connected to a computer that has a USB 1.1 interface.

<sup>2</sup> Third party USB ports are not supported.

<sup>3</sup> For detailed network specifications, see *Network* on page 215 and *Network User's Guide*.



# Network

## NOTE

For more information about the Network specifications, see Network User's Guide.

Model		MFC-9140CDN	MFC-9340CDW
<b>LAN</b>		You can connect your machine to a network for Network Printing, Network Scanning, PC-Fax Send, PC-Fax Receive (Windows® only) and Remote Setup <sup>1</sup> .  Also included is Brother BRAdmin Light <sup>2 3</sup> Network Management software.	
<b>Protocols</b>	IPv4	ARP, RARP, BOOTP, DHCP, APIPA(Auto IP), WINS/NetBIOS name resolution, DNS Resolver, mDNS, LLMNR responder, LPR/LPD, Custom Raw Port/Port9100, POP3, SMTP Client, IPP/IPPS, FTP Client and Server, CIFS Client, TELNET Server, SNMPv1/v2c/v3, HTTP/HTTPS server, TFTP client and server, ICMP, Web Services (Print/Scan), SNTP Client	
	IPv6	NDP, RA, DNS resolver, mDNS, LLMNR responder, LPR/LPD, Custom Raw Port/Port9100, POP3, IPP/IPPS, FTP Client and Server, CIFS Client, TELNET Server, SNMPv1/v2c/v3, HTTP/HTTPS server, TFTP client and server, SMTP Client, ICMPv6, SNTP Client, Web Service (Print/Scan)	
<b>Security Protocols</b>	Wired	APOP, POP before SMTP, SMTP-AUTH, SSL/TLS (IPPS, HTTPS, SMTP, POP), SNMP v3, 802.1x (EAP-MD5, EAP-FAST, PEAP, EAP-TLS, EAP-TTLS), Kerberos	
	Wireless	—	APOP, POP before SMTP, SMTP-AUTH, SSL/TLS (IPPS, HTTPS, SMTP, POP), SNMP v3, 802.1x (LEAP, EAP-FAST, PEAP, EAP-TLS, EAP-TTLS), Kerberos
<b>Wireless Network Security</b>		—	WEP 64/128 bit, WPA-PSK (TKIP/AES), WPA2-PSK (AES)
<b>Wireless Network Setup Support Utility</b>	<b>AOSS™</b>	—	Yes
	<b>WPS</b>	—	Yes

<sup>1</sup> See *Computer requirements* on page 217.

<sup>2</sup> (For Windows® users) Brother BRAdmin Light is available on the CD-ROM provided with the machine.  
(For Macintosh users) Brother BRAdmin Light is available as a download from <http://solutions.brother.com/>.

<sup>3</sup> (For Windows® users) If you require more advanced machine management, use the latest Brother BRAdmin Professional utility version that is available as a download from <http://solutions.brother.com/>.

## Direct Print feature

Model	MFC-9140CDN	MFC-9340CDW
Compatibility	—	PDF version 1.7 <sup>1</sup> , JPEG, Exif + JPEG, PRN (created by Brother printer driver), TIFF (scanned by all Brother MFC or DCP models), XPS version 1.0
Interface	—	USB direct interface

<sup>1</sup> PDF data including a JBIG2 image file, a JPEG2000 image file or a transparency file is not supported.

# Computer requirements

Computer Platform & Operating System Version		PC Interface			Processor	Hard Disk Space to install	
		USB <sup>2</sup>	10/100Base-TX (Ethernet)	Wireless 802.11b/g/n		For Drivers	For Applications
Windows® Operating System	Windows® XP Home <sup>1 4</sup> Windows® XP Professional <sup>1 4</sup>	Printing PC-Fax <sup>3</sup> Scanning			32bit (x86) or 64bit (x64) processor	150 MB	310 MB
	Windows® XP Professional x64 Edition <sup>1 4</sup>				64bit (x64) processor		
	Windows Vista® <sup>1 4</sup>				32bit (x86) or 64bit (x64) processor	500 MB	500 MB
	Windows® 7 <sup>1 4</sup>					650 MB	1.2 GB
	Windows® 8 <sup>1 4</sup>						
	Windows Server® 2003	N/A	Printing	32bit (x86) or 64bit (x64) processor	50 MB	N/A	
	Windows Server® 2003 x64 Edition			64bit (x64) processor			
	Windows Server® 2008			32bit (x86) or 64bit (x64) processor			
	Windows Server® 2008 R2			64bit (x64) processor			
	Windows Server® 2012						
Macintosh Operating System	Mac OS X v10.6.8	Printing			Intel® Processor	80 MB	400 MB
	OS X v10.7.x	PC-Fax (Send) <sup>3</sup>					
	OS X v10.8.x	Scanning					

<sup>1</sup> For WIA, 1200 x 1200 resolution. Brother Scanner Utility enables enhancing up to 19200 x 19200 dpi.

<sup>2</sup> Third party USB ports are not supported.

<sup>3</sup> PC-Fax supports black and white only.

<sup>4</sup> Presto! PageManager on the CD-ROM supports Microsoft®, Windows® XP, Windows Vista®, Windows® 7 and Windows® 8.

For the latest driver updates, visit <http://solutions.brother.com/>.

All trademarks, brand and product names are the property of their respective companies.

## Consumable items

Model			MFC-9140CDN	MFC-9340CDW	Model Name
Toner Cartridge	Inbox	Black	Approx. 2,500 pages A4 or Letter page <sup>1</sup>		—
		Cyan Magenta Yellow	Approx. 2,200 pages A4 or Letter page <sup>1</sup>		—
	Supply	Black	Approx. 2,500 pages A4 or Letter page <sup>1</sup>		TN-281BK
		Cyan Magenta Yellow	Approx. 2,200 pages A4 or Letter page <sup>1</sup>		TN-285C TN-285M TN-285Y
Drum Unit			Approx. 15,000 pages A4 or Letter page (1 page / job) <sup>2</sup>		DR-281CL <sup>3</sup> DR-281CL-BK <sup>4</sup> DR-281CL-CMY <sup>5</sup>
Belt Unit			Approx. 50,000 pages A4 or Letter page <sup>6</sup>		BU-220CL
Waste Toner Box			Approx. 50,000 pages A4 or Letter page <sup>6</sup>		WT-220CL

<sup>1</sup> Approx. cartridge yield is declared in accordance with ISO/IEC 19798.

<sup>2</sup> Drum life is approximate and may vary by type of use.

<sup>3</sup> Contains 4 pc. Drum Set.

<sup>4</sup> Contains 1 pc. Black Drum Unit.

<sup>5</sup> Contains 1 pc. Colour Drum Unit.

<sup>6</sup> Approx. yield is based on A4 or Letter single-sided pages.

### NOTE

- Brother does not recommend the use of consumables other than genuine Brother consumables.
- Your machine warranty may not cover any damage arising from the use of non genuine Brother consumables.

## A

Address Book	
changing .....	55
setting up .....	54
using .....	53
ADF (automatic document feeder)	
using .....	34
Answering machine (TAD)	
connecting .....	48
Apple Macintosh	
See Software User's Guide.	
Automatic	
fax receive .....	40
fax redial .....	53

## B

Back .....	9
Belt unit	
replacing .....	86

## C

Cancel .....	9
Cleaning	
corona wires .....	99
drum unit .....	102
LED head .....	97
scanner .....	98
Connecting	
external TAD (answering machine) .....	48
external telephone .....	50
Consumable items .....	69, 70, 71
Control panel overview .....	8
ControlCenter2 (for Macintosh)	
See Software User's Guide.	
ControlCenter4 (for Windows®)	
See Software User's Guide.	
Cordless telephone (non-Brother) .....	51

## D

Dialling	
a pause .....	54
Address Book .....	53
automatic fax redial .....	53
manual .....	53
Dimensions .....	206
Direct print .....	59, 60
specification .....	216
Document	
how to load .....	34, 35
Drum unit	
cleaning .....	99, 102
Drum units	
replacing .....	80

## E

Envelopes .....	25, 30, 32
Equalization .....	144
Error messages on touchscreen .....	114
Comm. Error .....	115
No Paper .....	117
Out of Memory .....	118
Print Unable XX .....	118
Scan Unable XX .....	120
Extension telephone, using .....	51
External telephone, connecting .....	50

## F

---

Fax codes	
changing .....	52
remote activation code .....	51
remote deactivation code .....	51
Fax Detect .....	42
Fax, stand-alone	
receiving	
fax detect .....	42
from extension telephone .....	50, 51
ring delay, setting .....	41
telephone line interference .....	144
sending .....	36
telephone line interference .....	144
Fax/Tel mode	
answering at extension telephones .....	51
F/T ring time (double-ring) .....	41
fax detect .....	42
receiving faxes .....	50
remote activation code .....	51
remote deactivation code .....	51
ring delay .....	41
Folio .....	28, 30

## G

---

Greyscale .....	210, 212
-----------------	----------

## H

---

Help	
Settings Tables .....	158
touchscreen messages .....	157
Home .....	9
Hook .....	51

## L

---

Labels .....	23, 30, 33
--------------	------------

## M

---

Machine information	
firmware version .....	155
how to reset the machine .....	156
reset functions .....	156
serial number .....	155
Macintosh	
See Software User's Guide.	
Maintenance, routine .....	95
replacing	
belt unit .....	86
drum units .....	80
toner cartridges .....	73
waste toner box .....	90
Manual	
dialling .....	53
Memory .....	206
Mode, entering	
copy .....	57
fax .....	36
Multi-line connections (PABX) .....	49

## N

---

Network	
faxing	
See Software User's Guide.	
printing	
See Network User's Guide.	
scanning	
See Software User's Guide.	
Network connectivity .....	214

## O

---

Out of Memory message .....	118
-----------------------------	-----

## P

Paper .....	29
how to load .....	21
in manual feed slot .....	23
in paper tray .....	21
recommended .....	29, 30
size .....	28, 29
tray capacity .....	30
type .....	28, 29
Pause .....	54
PC-Fax	
See Software User's Guide.	
Presto! PageManager	
See Software User's Guide. See also Help	
in the Presto! PageManager application.	
Print	
difficulties .....	135, 137
document from your computer .....	63
drivers .....	213
quality .....	145
resolution .....	213
specifications .....	213
Printing	
See Software User's Guide.	
Programming your machine .....	157

## Q

Quality	
printing .....	145

## R

Redial .....	53
Remote setup	
See Software User's Guide.	
Replacing	
belt unit .....	86
drum units .....	80
toner cartridges .....	73
waste toner box .....	90
Reports	
Transmission Verification .....	38
Resolution	
copy .....	211
fax (standard, fine, superfine,	
photo) .....	210
print .....	213
scan .....	212
Ring delay, setting .....	41

## S

Scan a document to a computer .....	64
Scanner glass	
using .....	35
Scanning .....	See Software User's Guide.
Settings Tables .....	158
Sockets	
EXT	
external telephone .....	50
TAD (answering machine) .....	48

## T

---

TAD (telephone answering device), external	
connecting .....	48
recording OGM .....	49
Telephone line	
connections .....	48
difficulties .....	137
interference .....	144
multi-line (PABX) .....	49
Text, entering .....	204
Toner cartridges	
replacing .....	73
Touchscreen LCD (liquid crystal display) .....	8, 157
Troubleshooting .....	135
document jam .....	124, 125
error messages on touchscreen .....	114
if you are having difficulty	
copy quality .....	140
incoming calls .....	140
network .....	142
paper handling .....	136
print quality .....	145
printing .....	135, 137
receiving faxes .....	138
scanning .....	141
sending faxes .....	139
software .....	141
telephone line .....	144
maintenance messages on touchscreen .....	114
paper jam .....	126, 127, 128, 130, 133

## V

---

VoIP .....	144
Volume, setting	
beeper .....	20
ring .....	20
speaker .....	20

## W

---

Waste toner box	
replacing .....	90
Weights .....	206
Wi-Fi Direct™ .....	5
Windows®	
See Software User's Guide.	
Wireless Network	
See Quick Setup Guide and Network User's Guide.	



## Brother FAX-PRINTER ASCs

Remark:The list was by the end of May,2012. Information in the list is subject to change without further notice. Please visit [www.95105369.com](http://www.95105369.com) to get the latest information.

省	城市	维修站名称	维修站地址	区号	电话
黑龙江	哈尔滨	黑龙江光电世纪科技开发有限公司	哈尔滨市南岗区南通大街258号船舶电子大世界中区138室	0451	82530790
	哈尔滨	哈尔滨松颖嘉禾高科技有限公司	哈尔滨市南岗区南通大街228号	0451	82539961
	哈尔滨	哈尔滨金佳特科技开发有限公司	哈尔滨市南岗区一曼街副2号泰山电子城507室	0451	82549588
	齐齐哈尔	齐齐哈尔天智商贸有限公司	龙沙区百脑惠电脑城办公楼2楼	0452	2432344
吉林	长春	长春市扬明兴业科技有限责任公司	吉林省长春市南关区人民大街7350号四季阳光小区三号楼101室	0431	85624398, 85622439
	长春	长春市臻正伟业办公设备有限责任公司	吉林省长春市工农大路1313号百脑汇科技大厦1222室	0431	85627141
	吉林	吉林市通联科贸有限公司	桃源160号11号网点	0432	62099000
辽宁	大连	大连东翱数码科技有限公司	大连市中山区长江路177号海源电子城3楼C007号	0411	81113639
	沈阳	沈阳慧园数码科技有限公司	沈阳市和平区三好街82号维用大厦512室	024	62220555
	沈阳	沈阳万众同心高科技有限公司	沈阳市和平区文萃路新城大2F北-14门2B03	024	23981270
	丹东	丹东金融电脑器材有限公司	丹东市振兴区青年大街23-6号	0415	3143999
内蒙古	包头	包头市万瑞电脑服务有限责任公司	包头市昆都仑区新光西路昆河镇镇政府附二楼	0472	2326777
	呼和浩特	呼和浩特市堃盟科技有限责任公司	新城区新华大街呼伦贝尔北路农牧业厅高层小区2号楼3单元3楼西户	0471	6286819\20 转8031

省	城市	维修站名称	维修站地址	区号	电话
甘肃	兰州	兰州丰安商贸有限公司	兰州市科技街 41 号	0931	8274760, 2136532
	兰州	兰州思源科技发展有限公司	甘肃省兰州市城关区科技街 185 号	0931	8272000
新疆	乌鲁木齐	乌鲁木齐华昭通信设备有限公司	乌鲁木齐扬子江路 213 号红十月花园东一区 6 号楼 4 单元 101 室	0991	4522839, 4522512
	乌鲁木齐	乌鲁木齐桑厦实业有限公司	乌鲁木齐市黄河路 396 号七一酱园 A 座 2711	0991	5866031
宁夏	银川	宁夏英士达办公设备有限公司	银川市文化东街 256 号	0951	6010943, 6081436
	银川	宁夏卓越电子技术服务有限公司	银川市鼓楼北街 18 号中晨电子二楼	0951	6014367
青海	西宁	西宁城西迅捷通讯经营部	西宁市胜利路电子市场西厅 45-47 号	0971	6135439
	西宁	西宁赛奥科技有限公司	青海省西宁市胜利路 58 号宏业大厦 2134 室	0971	6122563
陕西	西安	陕西康博机电有限公司	西安市雁塔路中段 68 号百脑汇电脑商城 13 层 A1311-16 室	029	87895140
	西安	西安赛尚电子科技有限公司	西安市育才路 65 号	029	85530775
	宝鸡	陕西隆辉信息产业发展有限公司	陕西省宝鸡市公园路 98 号 9 号楼一单元 101 室	0917	2876578
山西	太原	山西星凯科技有限公司	山西省太原市平阳路金茂大厦 A 座 15 层 E 户	0351	7528068
	太原	太原市艾替数码科技有限公司	太原市小店区寇庄北街 12 号	0351	7341081
	太原	太原华汉兴业科技发展有限公司	太原市小店区南内环街 100 号恒地大厦 17 层 1706-1708	0351	7240846, 4006530055

省	城市	维修站名称	维修站地址	区号	电话
河北	石家庄	石家庄泽朋商贸有限公司	石家庄市桥西区南小街金世界商贸区金悦公馆 704 房	0311	87887706
	石家庄	石家庄金业祥和办公设备有限公司	石家庄市和平东路 342 号时代方舟 A-2-701	0311	86212129
	保定	保定市皆凯八方办公设备有限公司	保定市劝业场路劝业场三层 A3 号	0312	2096095
	唐山	唐山三力伟业商贸有限公司	唐山市北新东道开滦体育馆东侧 50 米路南	0315	2837224
	邢台	邢台市佳华世纪科技有限公司	邢台市科技大厦底商佳文电子（临郭守敬北路）	0319	7613026
北京	北京	中国电子器材总公司	北京市东城区东皇城根南街 88 号	010	65266126
	北京	北京泰智峰科技有限公司	北京市朝阳区东土城路 9 号院内 15 号	010	84473121, 84473122
	北京	北京万华京港技贸有限公司	北京市海淀区中关村大街 18 号中关村数字物流港一层 0002 号	010	62653486
	北京	北京易禾鑫星科技服务有限公司	北京市海淀区中关村大街 22 号中科大厦 A806 室	010	62628292
	北京	北京志诚泰和数码办公设备股份有限公司	北京市海淀区知春路 108 号豪景大厦 A 座 10 层	010	62106393
天津	天津	天津市协坤办公设备有限公司	天津市南开区白堤路馨达园 11 号楼 1 门 701 室	022	27826840
河南	郑州	郑州永和电子有限公司	郑州市东风路 10 号外运电子商厦 301	0371	63661960
	郑州	郑州华信电子有限责任公司	郑州市文化路 68 号科技市场 D1-104 楼	0371	68209533
	商丘	商丘启航办公设备有限公司	商丘市民主中路高科电子城 E 区 11 号	0370	2310998
	洛阳	洛阳华文电子科技有限公司	洛阳市中州中路 2 号世纪电脑城 A 区 05-06	0379	64889186
	平顶山	河南华星电子有限公司	平顶山市建设路中段电子时代广场 2 楼 2004 室	0375	2976995, 2976992
	新乡	新乡市永丰电子商贸有限公司	新乡市和平大道体育中心北区 112 号	0373	3072022

省	城市	维修站名称	维修站地址	区号	电话
山东	济南	济南金志成通讯办公设备有限公司	济南市经一路延长线 15 号（天桥南头东北角）	0531	87061649
	青岛	青岛日升数码科技有限公司	青岛市辽宁路 226 号电子信息城 133-135 室	0532	83849398, 83847678
	济宁	济宁市任城区金成办公设备销售中心	济宁市建设北路 117 号仙营数码商城一楼	0537	2607822
	淄博	淄博齐赛科技市场华兴电脑经营部	淄博市北西六路齐赛科技市场老厅 108 室	0533	2771850
	潍坊	潍坊市电子街豪田传真机总汇	潍坊市四平路电子街 35 号	0536	8210877
	临沂	临沂批发城宇森办公设备销售部	山东省临沂市临西五路与水安路交汇西 600 米	0539	8067155
	烟台	烟台三站新天鸿办公设备商行	山东省烟台市芝罘屯路 12 号 3 楼 354 室	0535	2964171
湖北	武汉	武汉市大通电讯设备有限公司	武汉市硚口区利济北路 80 号财源大厦主楼一层 5 号门面	027	85426778
	襄阳	襄阳市三和现代办公设备有限公司	湖北省襄阳市春园路 17-11 号（火炬大厦旁火炬路 1 号对面）	0710	3233001
	武汉	武汉鑫宝丰盛科技有限公司	武汉市洪山区珞瑜路华中数码城 9088B	027	51854915
	荆州	荆州市维希数码办公设备有限责任公司	荆州市沙市区红门路 23 号飞腾电脑城 5015	0716	4310075
	十堰	十堰金铭科贸有限公司	十堰市朝阳北路 8 号泰弘电脑城 A2-22	0719	8264500

省	城市	维修站名称	维修站地址	区号	电话
江苏	苏州	苏州工业园区长江通讯设备有限公司	苏州市沧浪区滚绣坊 49-51 号（近乌鹊桥）	0512	65155875
	无锡	无锡市锡杰办公设备有限公司	无锡市中山路 88 号明珠大厦 2 号楼 804 室	0510	82723607 转 808
	南京	南京天多办公设备服务有限公司	南京市珠江路东大影壁 1 号院内	025	84723315
	常州	常州市信成办公设备有限公司	常州市怀德北路 23 号（瑞金医院广场南）	0519	86622369
	盐城	盐城市国通数码网络有限公司	盐城市纱井头 6 号楼 3 号	0515	88319628
	徐州	徐州市金力新技术有限公司	徐州市中山南路海云电脑大厦 213-214 室	0516	83813900, 83813600
	南通	南通雨顺现代办公设备有限公司	南通市濠东路 203 号	0513	85108308
	淮安	淮安市淮海办公设备有限公司	淮安市淮海南路 1 号财富广场南侧 B06-2 门店	0517	83998668, 83999668
	昆山	昆山万能达办公设备有限公司	昆山市市后街 178 号 78 栋	0512	57704911
	连云港	连云港天朝科技有限公司	连云港市新浦区通灌南路国安商城 1-19 号	0518	85517178
	常熟	常熟市金兰通讯器材有限责任公司	常熟市招商城小商品市场 4 楼 1 号	0512	52753955
	镇江	镇江星辰物资贸易有限公司	镇江市健康路 6 号五环大楼一楼西	0511	85015860
	扬州	扬州市恒鼎商贸有限公司	扬州市文昌中路 362 号（琼花观西廊坊）	0514	87361860, 85112311
	泰州	泰州市海陵区蓝海狮贸易有限公司	江苏省泰州市海陵区青年北路 219 号金茂大厦 711 室	0523	86212300

省	城市	维修站名称	维修站地址	区号	电话
上海	上海	上海发思达企业发展有限公司	上海市徐汇区零陵路 23 号	021	64162760
	上海	上海发思达办公通信设备有限公司	上海市共和新路 1207 号 7 号楼 3 楼	021	51005128
	上海	上海群盛办公设备有限公司	上海市浦东新区杨高南路 1677 弄 33 号	021	4008803969, 58730801
	上海	上海中纺电子系统有限公司	上海市延安西路 1754 号	021	52570565
浙江	温州	温州科教数码有限公司	温州市黎明西路 231 号 海螺大楼 2 楼北 203-205 室	0577	56588137, 88861058
	宁波	宁波新中讯数码产品有限公司	宁波市镇明路 516 号	0574	87303595
	台州	台州市路桥天虹办公设备商行	台州市路桥区腾达路电子数码城二楼 2646 号（世纪广场西侧）	0576	82438802, 82517646
	义乌	义乌市剑达通讯器材有限公司	义乌市银龙商务楼 B19-20 号	0579	85841777
	杭州	杭州盛瑞办公用品有限公司	杭州市教工路 123 号华门商务中心 502 室	0571	56771600
	杭州	杭州蓝天电脑服务有限公司	杭州市学院路 58 号华星创业大楼 103 号	0571	56831125
	绍兴	绍兴市越城恒誉办公设备商店	绍兴市长桥直街 110 号	0575	85089619
	嘉兴	嘉兴市理想商贸科技有限公司	嘉兴市越秀北路 146 号	0573	82117943
	瑞安	瑞安市兄弟办公通讯设备维修中心	瑞安市瑞光大道 302-306 号	0577	65626699

省	城市	维修站名称	维修站地址	区号	电话
安徽	合肥	合肥宝龙四凯信息科技有限公司	合肥市金寨路 92 号高科技广场北 2 座 12A	0551	3638800
	芜湖	芜湖市先通通讯器材经营部	芜湖市北京西路 7-3-4 号	0553	3866100, 3855100
	阜阳	阜阳市诚信电脑有限公司	阜阳市颍州北路 180 号 (国贸北 150 米)	0558	2270007
	滁州	滁州市飞鸿电子科技有限公司	滁州市紫薇北路 1093 号 (汽车站西大门)	0550	2158999
	六安	六安宇恒数码科技有限公司	六安市古楼街 B 区 27 号	0564	3325602
江西	南昌	南昌鸿邮办公自动化有限公司	江西省南昌市八一大道 135 号 8 楼 (长运商贸城 A 座 8 楼)	0791	86204110
	南昌	江西怡瑞科技发展有限公司	南昌市洪都中大道 158 号鸿雁电子市场 N 栋 2 号	0791	88600759
	九江	九江怡和信息技术有限公司	九江市滨江路 289 号滨江国际 D 座 1501 室	0792	8103338
	南昌	南昌盛瑞办公用品有限公司	南昌市八一大道 96 号华龙国际大厦 605 室	0791	82080627
	上饶	上饶市佳忆通贸易有限公司	上饶市中山西路 86 号	0793	8211700
湖南	长沙	湖南长沙正道电子贸易有限公司	长沙市朝阳路 253 号铁银商务楼 501 室	0731	84130061
	长沙	湖南金悦科技发展有限公司	湖南长沙解放东路 10 号	0731	84131468
	岳阳	岳阳天娇数码科技有限公司	岳阳市巴陵中路天正电脑城二楼 216 号	0730	3229812
四川	成都	成都欣光电科技有限责任公司	成都市武侯区致民路 34 号附 29 号 1 栋 1 层 21002 号	028	85502261, 65813101
	成都	成都成百办公用品连锁有限公司	成都市一环路南二段 2 号新世纪花园东楼 11D	028	86622678
	成都	成都新浦科技有限责任公司	成都市一环路南一段 20 号普利大厦 B 座 803 室	028	86310343

省	城市	维修站名称	维修站地址	区号	电话
重庆	重庆	重庆华锐办公通讯设备有限公司	重庆市渝中区大同路 45 号大同方城市公寓 13 楼 17 室	023	63805703
	重庆	重庆西物办公设备有限责任公司	重庆市九龙坡区科创路 65 号（渝高广场 B 座）1-3-8 号	023	61578200
贵州	贵阳	贵阳新地科技有限公司	贵阳市都司路 128 号乡企城千千代公寓 12-5 号	0851	5807472
	贵阳	贵州天宇办公设备有限公司	贵阳市富水中路 11 号恒生大厦 20 楼	0851	5810111
云南	昆明	昆明春秋数码科技有限公司	昆明市教益路戎锦花园 9 幢 105 室	0871	5198286
福建	福州	福州正威数码科技有限公司	福州市东大路 150 号恒裕大厦西侧一楼	0591	87326462
	泉州	泉州市新境界数码科技有限公司	泉州市鲤城区九一路 108 号	0595	22176716, 22287718
	厦门	厦门市汉韦电子有限公司	福建省厦门市湖里区仙岳路 680 号龙门天下 10 号店（后）	0592	5500712
	漳州	漳州市瑞宝办公设备有限公司	漳州市芗城区南昌路电子城 B2 栋 25 号	0596	2097110
	龙岩市	龙岩市拓普晟电子有限公司	龙岩市新罗区交易城数码广场 C-16 号	0597	2234520



省	城市	维修站名称	维修站地址	区号	电话
广东	广州	广州市天循办公设备有限公司	广州市天河区体育东横街南雅苑 66 号 101 室	020	85515469
	广州	广州市安桦办公设备有限公司	广州市天河区石牌东陶育路 1 号之五（国防大厦东、君紫花园内）	020	38899279
	深圳	深圳市永安创新办公设备有限公司	深圳市福田区振兴路上步工业区 505 栋 3 层 312 室	0755	83253790
	东莞	东莞市东城永安办公设备经营部	东莞市东城区南城路 116 号（岗贝路口）	0769	22215855
	珠海	珠海市香洲信兴办公设备商场	珠海市香洲区湾仔沙瀚高商业广场 138 号	0756	2132275
	深圳	深圳市威玛特办公设备有限公司	深圳市福田区华强北路上步工业区 205 栋 4078 室		8008303255 (直拨)
	广州	广州置安数码科技有限公司	广州市天河区天河路 490 号壬丰大厦 1905 室	020	38886959
	汕头	汕头市铭虹办公设备有限公司	汕头市澄海区外环西路消防大队斜对面	0754	85717295
	深圳	深圳市恒威佳讯数码科技有限公司	深圳市福田区振华路 56 号兰光大厦 C 座 3 楼 319 室	0755	83649323
	惠州	惠州市华威达办公设备有限公司	惠州市黄塘惠州电脑城新区 CA08	0752	2120050
	江门	江门市华信兴智能科技发展有限公司	江门市环市一路 15 号 109 室	0750	8221222
	中山	中山市西区天循办公设备经营部	中山市西区富华道 6 号西苑电脑城 1107 号	0760	86116328
	东莞	东莞市云轩办公设备有限公司	东莞市虎门太沙路 64 号太平广场花园 3 楼 3236 室	0769	82888988
	珠海	珠海市联创办公设备有限公司	珠海市香洲碧海路 77 号濠海大厦 B 座 302 室	0756	2212955

省	城市	维修站名称	维修站地址	区号	电话
广西	南宁	南宁市迪翔科技有限公司	南宁市星湖路 17-3 号龙华大厦西楼 3 楼 318 号	0771	5876145
	南宁	南宁市安华办公设备有限公司	南宁市星湖路南二里 3 号星湖综合楼一楼	0771	5357290
海南	海口	海口美兰天舜办公设备经营部	海口市海秀路 DC 商业城新区二楼 212 档	0898	66757428

National service hotline: 95105369 (Or 021-62371303)

Working Hours: 9:00 ~ 18:00 (Except Saturday, Sunday and holidays)

To search ASCs/Drivers/Manuals, etc, please visit our service website:

[www.95105369.com](http://www.95105369.com).

To search consumables purchase shop, please visit Brother company website:

[www.brother.cn](http://www.brother.cn).

BROTHER(CHINA) LTD.

# brother®

**Visit us on the World Wide Web**  
**<http://www.brother.com/>**

These machines are approved for use in the country of purchase only. Local Brother companies or their dealers will only support machines purchased in their own countries.



[www.brotherearth.com](http://www.brotherearth.com)

## Free Manuals Download Website

<http://myh66.com>

<http://usermanuals.us>

<http://www.somanuals.com>

<http://www.4manuals.cc>

<http://www.manual-lib.com>

<http://www.404manual.com>

<http://www.luxmanual.com>

<http://aubethermostatmanual.com>

Golf course search by state

<http://golfingnear.com>

Email search by domain

<http://emailbydomain.com>

Auto manuals search

<http://auto.somanuals.com>

TV manuals search

<http://tv.somanuals.com>