



# Installation, Start-Up and Service Instructions

## CONTENTS

	Page
<b>SAFETY CONSIDERATIONS</b> .....	1,2
<b>INSTALLATION</b> .....	2-17
<b>Step 1 — Provide Unit Support</b> .....	2
• ROOF CURB	
• ALTERNATE UNIT SUPPORT	
• SLAB MOUNT	
<b>Step 2 — Remove Shipping Rails</b> .....	2
<b>Step 3 — Rig and Place Unit</b> .....	2
• POSITIONING	
• ROOF MOUNT	
• INSTALLATION ONTO CURB	
<b>Step 4 — Field Fabricate Ductwork</b> .....	9
<b>Step 5 — Make Unit Duct Connections</b> .....	9
• VERTICAL CONFIGURATION	
• HORIZONTAL APPLICATIONS	
<b>Step 6 — Install Flue Hood and Inlet Hood</b> .....	10
<b>Step 7 — Trap Condensate Drain</b> .....	10
<b>Step 8 — Install Gas Piping</b> .....	10
<b>Step 9 — Make Electrical Connections</b> .....	11
• FIELD POWER SUPPLY	
• FIELD CONTROL WIRING	
<b>Step 10 — Install Outdoor-Air Hood</b> .....	12
• MANUAL DAMPER ASSEMBLY	
<b>Step 11 — Position Optional Power Exhaust or Barometric Relief Damper Hood</b> .....	16
<b>Step 12 — Non-Fused Disconnect</b> .....	16
<b>Step 13 — Install All Accessories</b> .....	16
<b>PRE-START-UP</b> .....	18
<b>START-UP</b> .....	18-46
<b>Unit Preparation</b> .....	18
<b>Compressor Mounting</b> .....	18
<b>Refrigerant Service Parts</b> .....	18
<b>Crankcase Heater(s)</b> .....	18
<b>Compressor Phasing</b> .....	18
<b>Internal Wiring</b> .....	18
<b>Evaporator Fan</b> .....	18
<b>Condenser Fans and Motors</b> .....	19
<b>Return Air Filters</b> .....	19
<b>Outdoor Air Inlet Screens</b> .....	19
<b>Gas Heat</b> .....	19
<b>Optional EconoMiSer IV</b> .....	40
<b>Operating Sequence</b> .....	45
<b>SERVICE</b> .....	46-54
<b>Cleaning</b> .....	46
<b>Lubrication</b> .....	46
<b>Evaporator Fan Service and Replacement</b> .....	47
<b>Evaporator Fan Performance Adjustment</b> .....	47
<b>Belt Tension Adjustment</b> .....	47
<b>Condenser-Fan Adjustment</b> .....	47
<b>Power Failure</b> .....	48
<b>Refrigerant Charge</b> .....	48
<b>Gas Valve Adjustment</b> .....	48
<b>Main Burners</b> .....	48
<b>Filter Drier</b> .....	50
<b>Protective Devices</b> .....	50

<b>Relief Devices</b> .....	50
<b>Control Circuit, 24-V</b> .....	50
<b>Replacement Parts</b> .....	50
<b>Diagnostic LEDs</b> .....	50
<b>TROUBLESHOOTING</b> .....	55-59
<b>Unit Troubleshooting</b> .....	55
<b>EconoMiSer IV Troubleshooting</b> .....	58
<b>START-UP CHECKLIST</b> .....	CL-1

## SAFETY CONSIDERATIONS

Installation and servicing of air-conditioning equipment can be hazardous due to system pressure and electrical components. Only trained and qualified service personnel should install, repair, or service air-conditioning equipment.

Untrained personnel can perform the basic maintenance functions of cleaning coils and filters and replacing filters. All other operations should be performed by trained service personnel. When working on air-conditioning equipment, observe precautions in the literature, tags and labels attached to the unit, and other safety precautions that may apply.

Follow all safety codes. Wear safety glasses and work gloves. Use quenching cloth for unbrazing operations. Have fire extinguishers available for all brazing operations.

### ▲ WARNING

Before performing service or maintenance operations on unit, turn off main power switch to unit. Electrical shock could cause personal injury.

### ▲ WARNING

1. Improper installation, adjustment, alteration, service, or maintenance can cause property damage, personal injury, or loss of life. Refer to the User's Information Manual provided with this unit for more details.
2. Do not store or use gasoline or other flammable vapors and liquids in the vicinity of this or any other appliance.

#### What to do if you smell gas:

1. DO NOT try to light any appliance.
2. DO NOT touch any electrical switch, or use any phone in your building.
3. IMMEDIATELY call your gas supplier from a neighbor's phone. Follow the gas supplier's instructions.
4. If you cannot reach your gas supplier, call the fire department.

### ▲ WARNING

Disconnect gas piping from unit when pressure testing at pressure greater than 0.5 psig. Pressures greater than 0.5 psig will cause gas valve damage resulting in hazardous condition. If gas valve is subjected to pressure greater than 0.5 psig, it *must* be replaced before use. When pressure testing field-supplied gas piping at pressures of 0.5 psig or less, a unit connected to such piping must be isolated by closing the manual gas valve(s).

**IMPORTANT:** Units have high ambient temperature operating limits. If limits are exceeded, the units will automatically lock the compressor out of operation. Manual reset will be required to restart the compressor.

## INSTALLATION

### Step 1 — Provide Unit Support

**ROOF CURB** — Assemble or install accessory roof curb in accordance with instructions shipped with this accessory. See Fig. 1. Install insulation, cant strips, roofing, and counter flashing as shown. Ductwork can be installed to roof curb before unit is set in place. Ductwork must be attached to curb and not to the unit. Curb must be level. This is necessary to permit unit drain to function properly. Unit leveling tolerance is  $\pm 1/16$  in. per linear ft in any direction. Refer to Accessory Roof Curb Installation Instructions for additional information as required. When accessory roof curb is used, unit may be installed on class A, B, or C roof covering material. Carrier roof curb accessories are for flat roofs or slab mounting.

**IMPORTANT:** The gasketing of the unit to the roof curb is critical for a watertight seal. Install gasket with the roof curb as shown in Fig. 1. Improperly applied gasket can also result in air leaks and poor unit performance. Do not slide unit to position on roof curb.

**ALTERNATE UNIT SUPPORT** — When a curb cannot be used, install unit on a noncombustible surface. Support unit with sleepers, using unit curb support area. If sleepers cannot be used, support long sides of unit with a minimum of 3 equally spaced 4-in. x 4-in. pads on each side.

**SLAB MOUNT (Horizontal Units Only)** — Provide a level concrete slab that extends a minimum of 6 in. beyond unit cabinet. Install a gravel apron in front of condenser coil air inlet to prevent grass and foliage from obstructing airflow.

**NOTE:** Horizontal units may be installed on a roof curb if required.

**Step 2 — Remove Shipping Rails** — Remove shipping rails prior to lowering unit onto roof curb. See Fig. 2. The rails are attached to the unit at both the return end and condenser end. Remove the screws from both ends of each rail. Be careful not to drop the rails onto any surface that could be damaged. Discard the rails. It is important to replace the screws into the unit to avoid any air or water leakage.

### ▲ CAUTION

Do not allow the shipping rail to drop on the roof surface. Damage to the roof surface may result.

**Step 3 — Rig and Place Unit** — Inspect unit for transportation damage. See Tables 1-3 for physical data. File any claim with transportation agency.

### ▲ CAUTION

All panels must be in place when rigging. Unit is not designed for handling by fork truck. Damage to unit may result.

Do not drop unit; keep upright. Use spreader bars over unit to prevent sling or cable damage. Rollers may be used to move unit across a roof. Level by using unit frame as a reference; leveling tolerance is  $\pm 1/16$  in. per linear ft in any direction. See Fig. 3 for additional information. Unit rigging weight is shown in Fig. 3.

Four lifting holes are provided in the unit base rails as shown in Fig. 3. Refer to rigging instructions on unit.

**POSITIONING** — Maintain clearance, per Fig. 4, around and above unit to provide minimum distance from combustible materials, proper airflow, and service access.

Do not install unit in an indoor location. Do not locate air inlets near exhaust vents or other sources of contaminated air. For proper unit operation, adequate combustion and ventilation air must be provided in accordance with Section 5.3 (Air for Combustion and Ventilation) of the National Fuel Gas Code, ANSI Z223.1 (American National Standards Institute).

Although unit is weatherproof, guard against water from higher level runoff and overhangs.

Locate mechanical draft system flue assembly at least 4 ft from any opening through which combustion products could enter the building, and at least 4 ft from any adjacent building (or per local codes). When unit is located adjacent to public walkways, flue assembly must be at least 7 ft above grade.

**ROOF MOUNT** — Check building codes for weight distribution requirements. Unit operating weight is shown in Table 1.

**INSTALLATION ONTO CURB** — The 48HJ units are designed to fit on the accessory full perimeter curb. Correct placement of the unit onto the curb is critical to operating performance. To aid in correct positioning,  $3/8$ -in. diameter locating holes have been added to the unit base rails. When placing the unit, these holes should line up with the roof curb edge as shown in Fig. 5 and 6, to assure proper duct opening alignment. For placement on the roof curb, use the alignment holes located approximately 2-in. from the end of the base rail on the return end of the unit. See labels on the side of the unit for more details.

### ▲ CAUTION

Do not slide unit to position it when it is sitting on the curb. Curb gasketing material may be damaged and leaks may result.

ROOFCURB ACCESSORY	CURB HEIGHT	DESCRIPTION	C	D
CRRFCURB018C00	1'-2" (356)	ROOF CURB 14" HIGH	3'-1 15/16" (963)	9'-6 7/16" (2906)
CRRFCURB019C00	2'-0" (610)	ROOF CURB 24" HIGH	3'-1 15/16" (963)	9'-6 7/16" (2906)

- NOTES:
1. ROOFCURB ACCESSORY IS SHIPPED DISASSEMBLED.
  2. DIMENSIONS IN ( ) ARE IN MILLIMETERS.
  3. DIRECTION OF AIRFLOW.
  4. ROOF CURB: 16 GA. (VA03-56) STEEL.
  5. TO PREVENT THE HAZARD OF STAGNANT WATER BUILD-UP IN THE UNIT DO NOT EXCEED CURB LEVELING TOLERANCES.
  6. CLEARANCE BETWEEN UNIT BASE RAIL AND CURB FLANGE IS 1/4-IN. (6 MM) ON EACH SIDE.

MAX CURB LEVELING TOLERANCES:

ROOFCURB	A		B	
	DEG.	IN.	DEG.	IN.
CRRFCURB018C00 CRRFCURB019C00	.28	.57	.28	.42

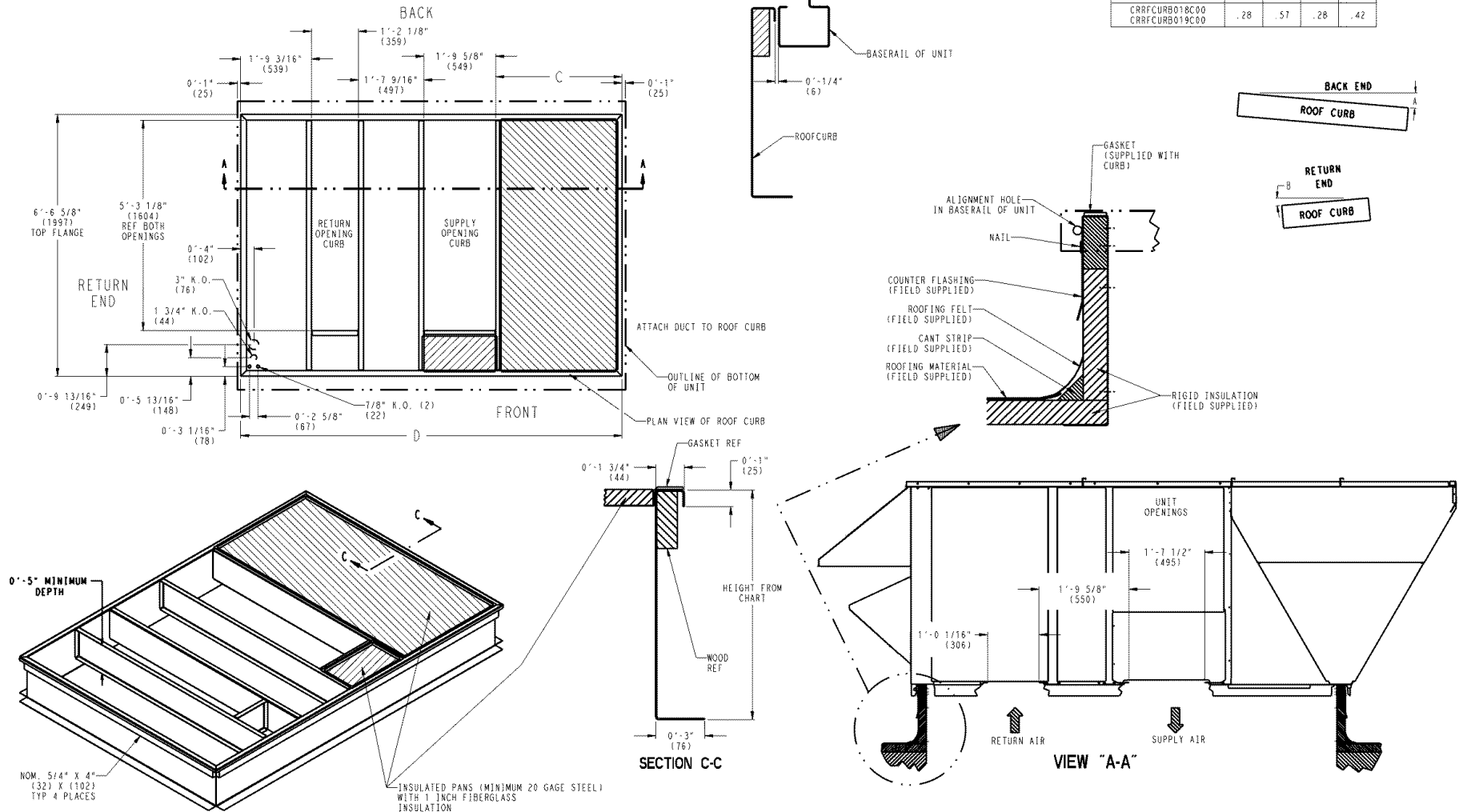


Fig. 1 — Roof Curb Details

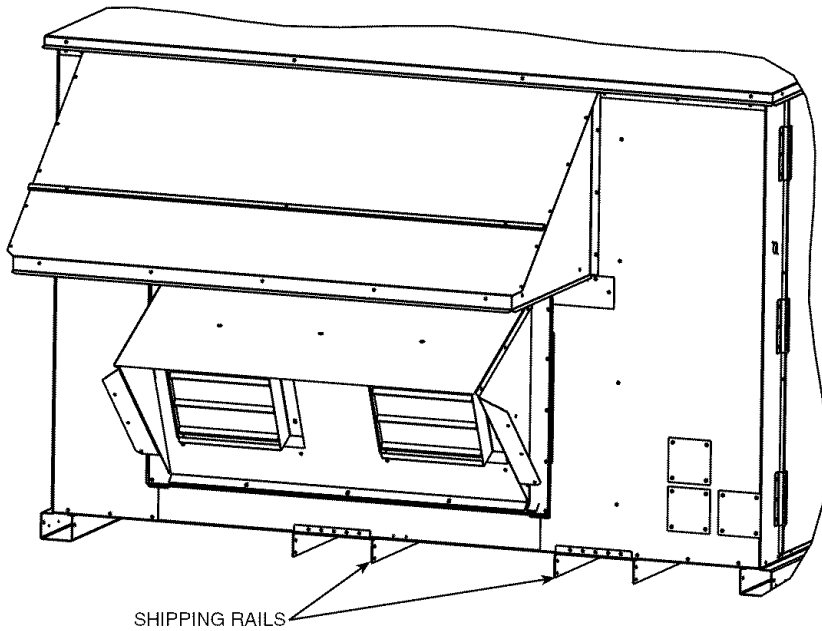


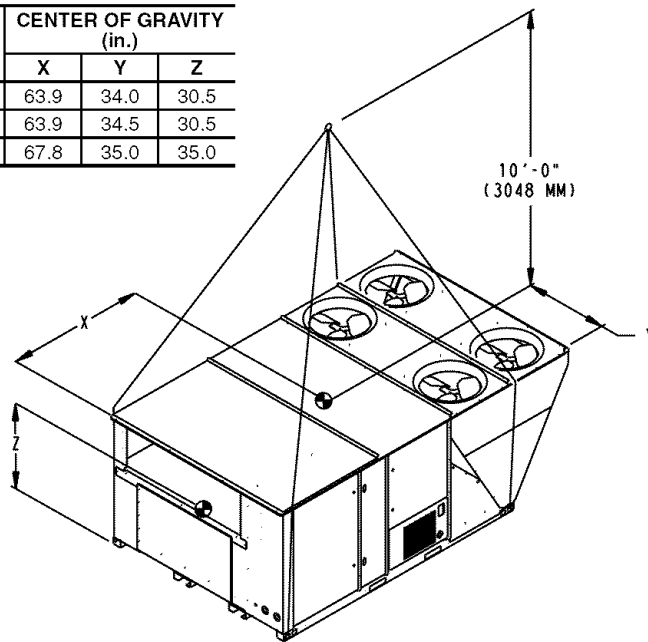
Fig. 2 — Shipping Rail Removal



**CAUTION - NOTICE TO RIGGERS:**  
**ALL PANELS MUST BE IN PLACE WHEN RIGGING.**

**NOTICE TO RIGGERS:** Rig by inserting hooks into unit base rails as shown. Maintain a distance of 120 inches (3048 MM) from top of unit to eyehook. Leave coil cover attached to unit while rigging to protect coil of unit from damage.

UNIT SIZE	MAX WEIGHT (lb)	CENTER OF GRAVITY (in.)		
		X	Y	Z
020	3358	63.9	34.0	30.5
024	3380	63.9	34.5	30.5
028	3769	67.8	35.0	35.0



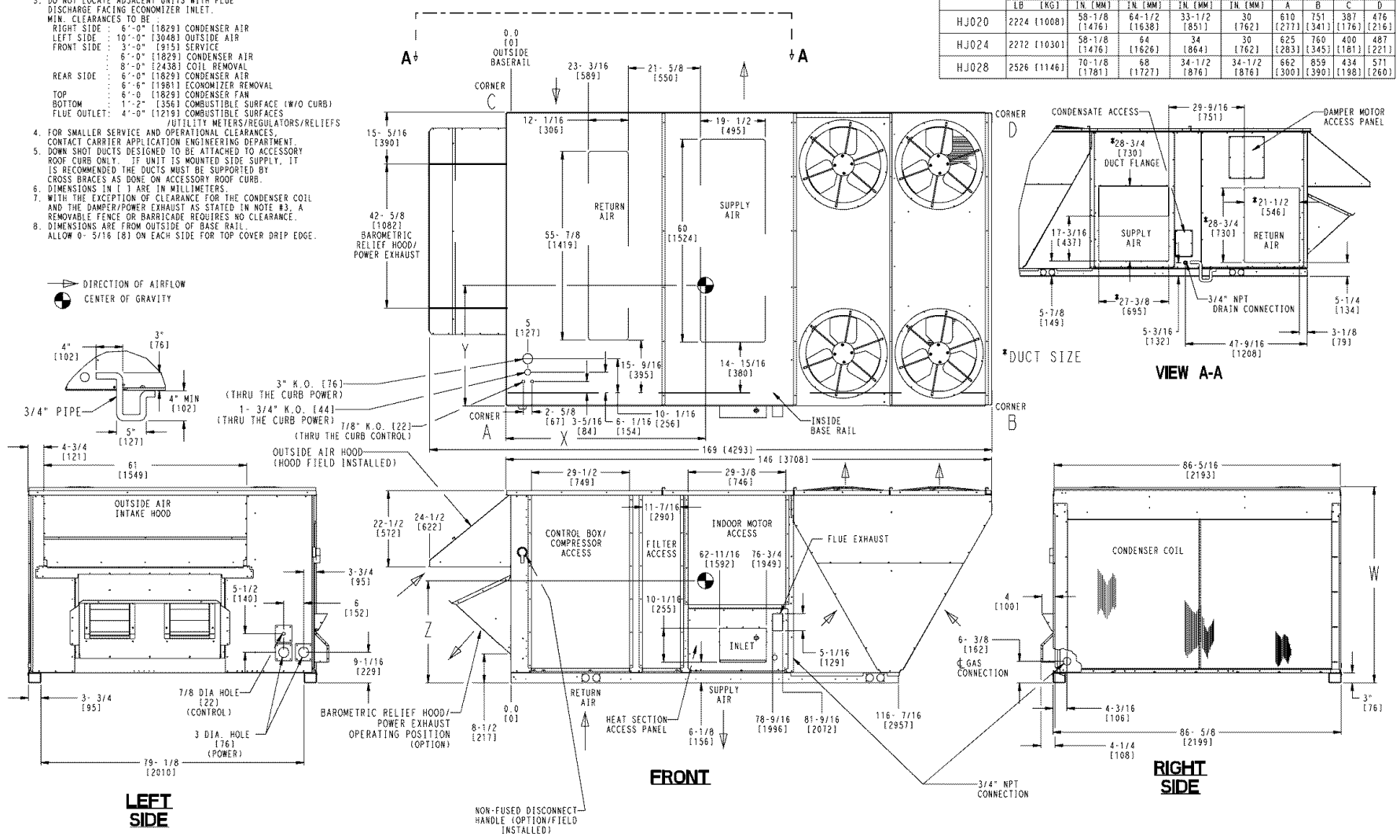
**NOTE:**  
 Add 150lb (68kg) for domestic crating.

Fig. 3 — Rigging Details

**NOTES:**

- FOR OUTDOOR USE ONLY.
- WEIGHTS SHOWN ARE FOR 48HJ (LOW HEAT) UNIT WITH MANUAL 25K OUTDOOR AIR OPTION, ALUMINUM COILS, AND STANDARD DRIVE. FOR WEIGHTS OF OPTIONAL EQUIPMENT CONSULT PRODUCT DATA BOOK.
- DO NOT LOCATE ADJACENT UNITS WITH FLUE DISCHARGE FACING ECONOMIZER INLET.  
MIN. CLEARANCES TO BE:  
RIGHT SIDE : 6'-0" [1829] CONDENSER AIR  
LEFT SIDE : 10'-0" [3048] OUTSIDE AIR  
FRONT SIDE : 3'-0" [915] SERVICE  
8'-0" [2438] COIL REMOVAL  
REAR SIDE : 6'-0" [1829] CONDENSER AIR  
6'-6" [1981] ECONOMIZER REMOVAL  
6'-0" [1829] CONDENSER FAN  
TOP : 1'-2" [356] COMBUSTIBLE SURFACE (W/O CURB)  
BOTTOM : 4'-0" [1219] COMBUSTIBLE SURFACES  
FLUE OUTLET:  
UTILILITY METERS/REGULATORS/RELIEFS  
CONTACT CARRIER APPLICATION ENGINEERING DEPARTMENT.
- FOR SMALLER SERVICE AND OPERATIONAL CLEARANCES, CONTACT CARRIER APPLICATION ENGINEERING DEPARTMENT.
- DOWN SHOT DUCTS DESIGNED TO BE ATTACHED TO ACCESSORY ROOF CURB ONLY. IF UNIT IS MOUNTED SIDE SUPPLY, IT IS RECOMMENDED THE DUCTS MUST BE SUPPORTED BY CROSS BRACES AS DONE ON ACCESSORY ROOF CURB.
- DIMENSIONS IN [ ] ARE IN MILLIMETERS.
- WITH THE EXCEPTION OF CLEARANCE FOR THE CONDENSER COIL AND THE DAMPER/POWER EXHAUST AS STATED IN NOTE #3, A REMOVABLE FENCE OR BARRICADE REQUIRES NO CLEARANCE.
- DIMENSIONS ARE FROM OUTSIDE OF BASE RAIL.  
ALLOW 0'-5/16 [8] ON EACH SIDE FOR TOP COVER DRIP EDGE.

➤ DIRECTION OF AIRFLOW  
● CENTER OF GRAVITY



**Fig. 4 — Base Unit Dimensions**

**Table 1 — Physical Data**

UNIT 48HJ	020	024	028
<b>NOMINAL CAPACITY (tons)</b>	18	20	25
<b>OPERATING WEIGHT (lb)</b>			
AI/AI*	2224	2272	2526
<b>COMPRESSOR</b>			
Quantity	3	3	2
Number of Refrigerant Circuits	3	3	2
Oil (ounces) Ckt A...Ckt B...Ckt C	68...68...90	90...90...90	110...110...N/A
<b>REFRIGERANT TYPE</b>	R-22	R-22	R-22
Expansion Device	TXV	TXV	TXV
Operating Charge (lb)			
Circuit A	13.1	13.8	21.8
Circuit B	12.7	13.9	20.3
Circuit C	15.2	15.5	N/A
<b>CONDENSER FAN</b>			
Nominal Cfm (Total, all fans)	14,000	14,000	21,000
Quantity...Diameter (in.)	4...22	4...22	6...22
Motor Hp...Rpm	1/4...1100	1/4...1100	1/4...1100
Watts Input (Total)	1400	1400	2100
<b>CONDENSER COIL</b>			
Rows...Fins/in.	2...17	2...17	2...17
Total Face Area (sq ft)	57.78	57.78	66.67
<b>EVAPORATOR FAN</b>			
Quantity...Size	2...15x11	2...15x11	2...15x11
Type Drive	Belt	Belt	Belt
Nominal Cfm	7000	8000	10,000
Motor Bearing Type	Ball	Ball	Ball
Maximum Allowable Fan Rpm	1400	1400	1400
<b>EVAPORATOR COIL</b>			
Rows...Fins/in.	3...15	4...15	4...15
Total Face Area (sq ft)	23.33	23.33	27.22
<b>FURNACE SECTION</b>			
Rollout Switch Cutout Temp (F)	225	225	225
Burner Orifice Diameter (in. ...drill size)	0.136...29	0.136...29	0.136...29
Gas	Natural	Natural	Natural
Thermostat Heat Anticipator Setting			
Stage 1 (amps)	0.98	0.98	0.98
Stage 2 (amps)	0.44	0.44	0.44
Gas Input (Btuh) HIGH HEAT			
Stage 1	317,000	317,000	317,000
Stage 2	400,000	400,000	400,000
Efficiency (Steady State) %	82	82	82
Temperature Rise Range	25-55	25-55	25-55
Gas Input (Btuh) MEDIUM HEAT			
Stage 1	281,000	281,000	281,000
Stage 2	365,000	365,000	365,000
Efficiency (Steady State) %	81	81	81
Temperature Rise Range	25-55	25-55	25-55
Gas Input (Btuh) LOW HEAT			
Stage 1	199,000	199,000	199,000
Stage 2	250,000	250,000	250,000
Efficiency (Steady State) %	82	82	82
Temperature Rise Range (F)	15-45	15-45	15-45
Manifold Pressure			
Natural Gas (in. wg)	3.00	3.00	3.00
Natural Gas (in. wg)	2.95	2.95	2.95
Gas Valve Quantity	1	1	1
Gas Valve Pressure Range	(in. wg)	(in. wg)	(in. wg)
Min-Max Allowable	5.5-13.0	5.5-13.0	5.5-13.0
Field Gas Connection Size (in. FPT)	(psig)	(psig)	(psig)
Min-Max Allowable	.235-.469	.235-.469	.235-.469
Field Gas Connection Size (in. FPT)	3/4	3/4	3/4
<b>HIGH-PRESSURE SWITCH (psig)</b>			
Cutout	426	426	426
Reset (Auto)	320	320	320
<b>OUTDOOR-AIR INLET SCREENS</b>			
Quantity...Size (in.)	3...20x25	3...20x25	3...20x25
<b>RETURN-AIR FILTERS</b>			
Quantity...Size (in.)	9...16x25	9...16x25	9...18x24

**LEGEND**

\*Aluminum evaporator coil and aluminum condenser coil.

N/A — Not Applicable  
 TXV — Thermostatic Expansion Valve

**Table 2 — Fan Motor and Drive Data — Vertical Supply/Return**

48HJ	020		024		028	
	203/230 and 460 V	575 V	203/230 and 460 V	575 V	203/230 and 460 V	575 V
<b>LOW RANGE</b>						
Motor Hp	N/A	N/A	3.7	5	5	5
Motor Nominal Rpm	N/A	N/A	1725	1745	1745	1745
Maximum Continuous Bhp	N/A	N/A	4.25	5.75	5.75	5.75
Maximum Continuous Watts	N/A	N/A	3698	4900	4900	4900
Motor Frame Size	N/A	N/A	56HZ	184T	S184T	184T
Motor Shaft Diameter (in.)	N/A	N/A	7/8	1 1/8	1 1/8	1 1/8
Fan Rpm Range	N/A	N/A	685-939	751-954	687-873	687-873
Motor Pulley Min. Pitch Diameter (in.)	N/A	N/A	2.7	3.7	3.7	3.7
Motor Pulley Max. Pitch Diameter (in.)	N/A	N/A	3.7	4.7	4.7	4.7
Blower Pulley Pitch Diameter (in.)	N/A	N/A	6.8	8.6	9.4	9.4
Blower Pulley Shaft Diameter (in.)	N/A	N/A	1.1875	1.1875	1.1875	1.1875
Blower Pulley Type	N/A	N/A	Fixed	Fixed	Fixed	Fixed
Pulley Center Line Distance (in.)	N/A	N/A	11.293-13.544	9.81-13.055	9.81-13.055	9.81-13.055
Belt, Quantity...Type...Length (in.)	N/A	N/A	1...BX...38	1...BX...40	1...BX...41	1...BX...41
Speed Change Per Turn — Moveable Pulley (rpm)	N/A	N/A	51	41	37	37
Moveable Pulley Maximum Full Turns	N/A	N/A	6	6	6	6
Factory Speed Setting (rpm)	N/A	N/A	812	853	780	780
<b>MID-LOW RANGE</b>						
Motor Hp	3.7	3	5	5	5	5
Motor Nominal Rpm	1725	1725	1745	1745	1745	1745
Maximum Continuous Bhp	4.25	3.45	5.75	5.75	5.75	5.75
Maximum Continuous Watts	3698	3149	4900	4900	4900	4900
Motor Frame Size	56HZ	56HZ	S184T	184T	S184T	184T
Motor Shaft Diameter (in.)	7/8	7/8	1 1/8	1 1/8	1 1/8	1 1/8
Fan Rpm Range	647-886	810-1072	949-1206	949-1206	805-1007	805-1007
Motor Pulley Min. Pitch Diameter (in.)	2.7	3.1	3.7	3.7	4.8	4.8
Motor Pulley Max. Pitch Diameter (in.)	3.7	4.1	4.7	4.7	6.0	6.0
Blower Pulley Pitch Diameter (in.)	7.2	6.6	6.8	6.8	10.4	10.4
Blower Pulley Shaft Diameter (in.)	1.1875	1.1875	1.1875	1.1875	1.1875	1.1875
Blower Pulley Type	Fixed	Fixed	Fixed	Fixed	Fixed	Fixed
Pulley Center Line Distance (in.)	11.293-13.544	11.286-14.475	9.81-13.055	9.81-13.055	9.81-13.055	9.81-13.055
Belt, Quantity...Type...Length (in.)	1...BX...38	1...BX...38	1...BX...38	1...BX...38	1...BX...45	1...BX...45
Speed Change Per Turn — Moveable Pulley (rpm)	48	52	51	51	40	40
Moveable Pulley Maximum Full Turns	6	6	6	6	6	6
Factory Speed Setting (rpm)	767	941	1078	1078	906	906
<b>MID-HIGH RANGE</b>						
Motor Hp	5	5	7.5	7.5	7.5	7.5
Motor Nominal Rpm	1745	1745	1745	1745	1745	1745
Maximum Continuous Bhp	5.75	5.75	8.63	8.63	8.63	8.63
Maximum Continuous Watts	4900	4900	7267	7267	7267	7267
Motor Frame Size	S184T	184T	S213T	S213T	S213T	S213T
Motor Shaft diameter (in.)	1 1/8	1 1/8	1 3/8	1 3/8	1 3/8	1 3/8
Fan Rpm Range	897-1139	873-1108	941-1176	941-1176	941-1176	941-1176
Motor Pulley Min. Pitch Diameter (in.)	3.7	3.7	4.8	4.8	4.8	4.8
Motor Pulley Max. Pitch Diameter (in.)	4.7	4.7	6.0	6.0	6.0	6.0
Blower Pulley Pitch Diameter (in.)	7.2	7.4	8.9	8.9	8.9	8.9
Blower Pulley Shaft Diameter (in.)	1.1875	1.1875	1.1875	1.1875	1.1875	1.1875
Blower Pulley Type	Fixed	Fixed	Fixed	Fixed	Fixed	Fixed
Pulley Center Line Distance (in.)	9.81-13.055	9.81-13.055	9.025-12.179	9.025-12.179	9.025-12.179	9.025-12.179
Belt, Quantity...Type...Length (in.)	1...BX...38	1...BX...38	1...BX...42	1...BX...42	1...BX...42	1...BX...42
Speed Change Per Turn — Moveable Pulley (rpm)	48	47	47	47	47	47
Moveable Pulley Maximum Full Turns	6	6	6	6	6	6
Factory Speed Setting (rpm)	1018	991	1059	1059	1059	1059
<b>HIGH RANGE</b>						
Motor Hp	7.5	7.5	10	10	10	10
Motor Nominal Rpm	1745	1745	1745	1745	1745	1745
Maximum Continuous Bhp	8.63	8.63	11.5	11.5	11.5	11.5
Maximum Continuous Watts	7267	7267	9582	9582	9582	9582
Motor Frame Size	S213T	S213T	S215T	S215T	S215T	S215T
Motor Shaft Diameter (in.)	1 3/8	1 3/8	1 3/8	1 3/8	1 3/8	1 3/8
Fan Rpm Range	1078-1274	1078-1274	1014-1297	1014-1297	1014-1297	1014-1297
Motor Pulley Min. Pitch Diameter (in.)	5.5	5.5	4.3	4.3	4.3	4.3
Motor Pulley Max. Pitch Diameter (in.)	6.5	6.5	5.5	5.5	5.5	5.5
Blower Pulley Pitch Diameter (in.)	8.9	8.9	7.4	7.4	7.4	7.4
Blower Pulley Shaft Diameter (in.)	1.1875	1.1875	1.1875	1.1875	1.1875	1.1875
Blower Pulley Type	Fixed	Fixed	Fixed	Fixed	Fixed	Fixed
Pulley Center Line Distance (in.)	9.025-12.179	9.025-12.179	9.025-12.179	9.025-12.179	9.025-12.179	9.025-12.179
Belt, Quantity...Type...Length (in.)	1...BX...42	1...BX...42	2...BX...38	2...BX...38	2...BX...38	2...BX...38
Speed Change Per Turn — Moveable Pulley (rpm)	39	39	57	57	57	57
Moveable Pulley Maximum Full Turns	6	6	6	6	6	6
Factory Speed Setting (rpm)	1176	1176	1156	1156	1156	1156

**LEGEND**

Bhp — Brake Horsepower  
 N/A — Not Applicable

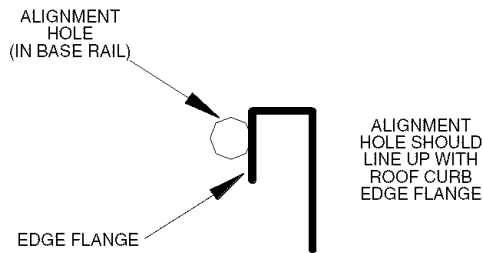
Table 3 — Fan Motor and Drive Data — Horizontal Supply/Return

48HJ	020		024		028	
	203/230 and 460 V	575 V	203/230 and 460 V	575 V	203/230 and 460 V	575 V
<b>LOW RANGE</b>						
Motor Hp	N/A	N/A	N/A	N/A	5	5
Motor Nominal Rpm	N/A	N/A	N/A	N/A	1745	1745
Maximum Continuous Bhp	N/A	N/A	N/A	N/A	5.75	5.75
Maximum Continuous Watts	N/A	N/A	N/A	N/A	4900	4900
Motor Frame Size	N/A	N/A	N/A	N/A	S184T	184T
Motor Shaft Diameter (in.)	N/A	N/A	N/A	N/A	1 <sup>1</sup> / <sub>8</sub>	1 <sup>1</sup> / <sub>8</sub>
Fan Rpm Range	N/A	N/A	N/A	N/A	687-873	687-873
Motor Pulley Min. Pitch Diameter (in.)	N/A	N/A	N/A	N/A	3.7	3.7
Motor Pulley Max. Pitch Diameter (in.)	N/A	N/A	N/A	N/A	4.7	4.7
Blower Pulley Pitch Diameter (in.)	N/A	N/A	N/A	N/A	9.4	9.4
Blower Pulley Shaft Diameter (in.)	N/A	N/A	N/A	N/A	1.1875	1.1875
Blower Pulley Type	N/A	N/A	N/A	N/A	Fixed	Fixed
Pulley Center Line Distance (in.)	N/A	N/A	N/A	N/A	9.81-13.055	9.81-13.055
Belt, Quantity...Type...Length (in.)	N/A	N/A	N/A	N/A	1...BX...41	1...BX...41
Speed Change Per Turn — Moveable Pulley (rpm)	N/A	N/A	N/A	N/A	37	37
Moveable Pulley Maximum Full Turns	N/A	N/A	N/A	N/A	6	6
Factory Speed Setting (rpm)	N/A	N/A	N/A	N/A	780	780
<b>MID-LOW RANGE</b>						
Motor Hp	3.7	3	3.7	5	5	5
Motor Nominal Rpm	1725	1725	1725	1745	1745	1745
Maximum Continuous Bhp	4.25	3.45	4.25	5.75	5.75	5.75
Maximum Continuous Watts	3698	3149	3698	4900	4900	4900
Motor Frame Size	56HZ	56HZ	56HZ	184T	S184T	184T
Motor Shaft Diameter (in.)	7 <sup>7</sup> / <sub>8</sub>	7 <sup>7</sup> / <sub>8</sub>	7 <sup>7</sup> / <sub>8</sub>	1 <sup>1</sup> / <sub>8</sub>	1 <sup>1</sup> / <sub>8</sub>	1 <sup>1</sup> / <sub>8</sub>
Fan Rpm Range	896-1227	863-1141	896-1227	873-1108	805-1007	805-1007
Motor Pulley Min. Pitch Diameter (in.)	2.7	3.1	2.7	3.7	4.8	4.8
Motor Pulley Max. Pitch Diameter (in.)	3.7	4.1	3.7	4.7	6.0	6.0
Blower Pulley Pitch Diameter (in.)	5.2	6.2	5.2	7.4	10.4	10.4
Blower Pulley Shaft Diameter (in.)	1.1875	1.1875	1.1875	1.1875	1.1875	1.1875
Blower Pulley Type	Fixed	Fixed	Fixed	Fixed	Fixed	Fixed
Pulley Center Line Distance (in.)	11.293-13.544	11.286-14.475	11.293-13.544	9.81-13.055	9.81-13.055	9.81-13.055
Belt, Quantity...Type...Length (in.)	1...BX...35	1...BX...38	1...BX...35	1...BX...38	1...BX...45	1...BX...45
Speed Change Per Turn — Moveable Pulley (rpm)	66	56	66	47	40	40
Moveable Pulley Maximum Full Turns	6	6	6	6	6	6
Factory Speed Setting (rpm)	1062	1002	1062	991	906	906
<b>MID-HIGH RANGE</b>						
Motor Hp	5	5	5	5	7.5	7.5
Motor Nominal Rpm	1745	1745	1745	1745	1745	1745
Maximum Continuous Bhp	5.75	5.75	5.75	5.75	8.63	8.63
Maximum Continuous Watts	4900	4900	4900	4900	7267	7267
Motor Frame Size	S184T	184T	S184T	184T	S213T	S213T
Motor Shaft Diameter (in.)	1 <sup>1</sup> / <sub>8</sub>	1 <sup>1</sup> / <sub>8</sub>	1 <sup>1</sup> / <sub>8</sub>	1 <sup>1</sup> / <sub>8</sub>	1 <sup>3</sup> / <sub>8</sub>	1 <sup>3</sup> / <sub>8</sub>
Fan Rpm Range	1113-1414	1042-1285	1113-1414	1113-1414	941-1176	941-1176
Motor Pulley Min. Pitch Diameter (in.)	3.7	4.3	3.7	3.7	4.8	4.8
Motor Pulley Max. Pitch Diameter (in.)	4.7	5.3	4.7	4.7	6.0	6.0
Blower Pulley Pitch Diameter (in.)	5.8	7.2	5.8	5.8	8.9	8.9
Blower Pulley Shaft Diameter (in.)	1.1875	1.1875	1.1875	1.1875	1.1875	1.1875
Blower Pulley Type	Fixed	Fixed	Fixed	Fixed	Fixed	Fixed
Pulley Center Line Distance (in.)	9.81-13.055	9.81-13.055	9.81-13.055	9.81-13.055	9.025-12.179	9.025-12.179
Belt, Quantity...Type...Length (in.)	1...BX...35	1...BX...38	1...BX...35	1...BX...35	1...BX...42	1...BX...42
Speed Change Per Turn — Moveable Pulley (rpm)	60	48	60	60	47	47
Moveable Pulley Maximum Full Turns	6	6	6	6	6	6
Factory Speed Setting (rpm)	1264	1164	1264	1264	1059	1059
<b>HIGH RANGE</b>						
Motor Hp	7.5	7.5	7.5	7.5	10	10
Motor Nominal Rpm	1745	1745	1745	1745	1745	1745
Maximum Continuous Bhp	8.63	8.63	8.63	8.63	11.5	11.5
Maximum Continuous Watts	7267	7267	7267	7267	9582	9582
Motor Frame Size	S213T	S213T	S213T	S213T	S215T	S215T
Motor Shaft Diameter (in.)	1 <sup>3</sup> / <sub>8</sub>	1 <sup>3</sup> / <sub>8</sub>	1 <sup>3</sup> / <sub>8</sub>	1 <sup>3</sup> / <sub>8</sub>	1 <sup>3</sup> / <sub>8</sub>	1 <sup>3</sup> / <sub>8</sub>
Fan Rpm Range	1096-1339	1096-1339	1096-1339	1096-1339	1014-1297	1014-1297
Motor Pulley Min. Pitch Diameter (in.)	5.4	5.4	5.4	5.4	4.3	4.3
Motor Pulley Max. Pitch Diameter (in.)	6.6	6.6	6.6	6.6	5.5	5.5
Blower Pulley Pitch Diameter (in.)	8.6	8.6	8.6	8.6	7.4	7.4
Blower Pulley Shaft Diameter (in.)	1.1875	1.1875	1.1875	1.1875	1.1875	1.1875
Blower Pulley Type	Fixed	Fixed	Fixed	Fixed	Fixed	Fixed
Pulley Center Line Distance (in.)	9.025-12.179	9.025-12.179	9.025-12.179	9.025-12.179	9.025-12.179	9.025-12.179
Belt, Quantity...Type...Length (in.)	1...BX...42	1...BX...42	1...BX...42	1...BX...42	1...BX...38	1...BX...38
Speed Change Per Turn — Moveable Pulley (rpm)	49	49	49	49	57	57
Moveable Pulley Maximum Full Turns	6	6	6	6	6	6
Factory Speed Setting (rpm)	1218	1218	1218	1218	1156	1156

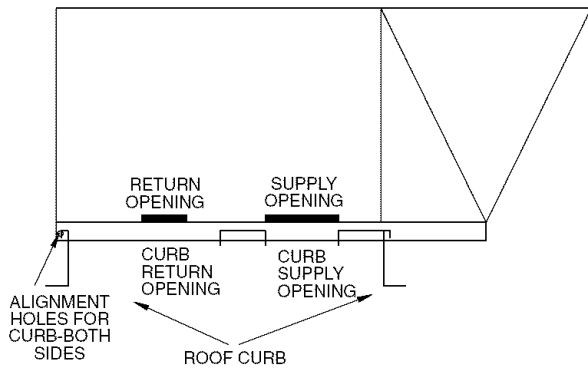
LEGEND

Bhp — Brake Horsepower  
 N/A — Not Applicable





**Fig. 5 — Alignment Hole Details**



**Fig. 6 — Alignment Hole Location**

**Step 4 — Field Fabricate Ductwork** — On vertical units, secure all ducts to roof curb and building structure. *Do not connect ductwork to unit.* For horizontal applications, field-supplied flanges should be attached to horizontal discharge openings and all ductwork secured to the flanges. Insulate and weatherproof all external ductwork, joints, and roof openings with counter flashing and mastic in accordance with applicable codes.

Ducts passing through an unconditioned space must be insulated and covered with a vapor barrier.

If a plenum return is used on a vertical unit, the return should be ducted through the roof deck to comply with applicable fire codes.

A minimum clearance is not required around ductwork. Cabinet return-air static pressure (a negative condition) shall not exceed 0.35 in. wg with economizer or 0.45 in. wg without economizer.

These units are designed for a minimum continuous return-air temperature in heating of 50 F (dry bulb), or an intermittent operation down to 45 F (dry bulb), such as when used with a night set-back thermostat.

To operate at lower return-air temperatures, a field-supplied outdoor-air temperature control must be used to initiate both stages of heat when the temperature is below 45 F. Indoor comfort may be compromised when these lower air temperatures are used with insufficient heating temperature rise.

**Step 5 — Make Unit Duct Connections**

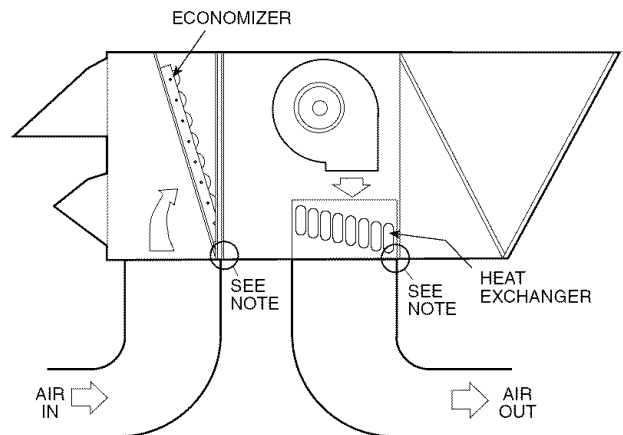
**VERTICAL CONFIGURATION** — Unit is shipped for vertical supply and return duct connections. Ductwork openings are shown in Fig. 1 and 4. Duct connections for vertical configuration are shown in Fig. 7. Field-fabricated concentric ductwork may be connected as shown in Fig. 8 and 9. The unit is designed to attach the ductwork to the roof curb. Do not attach duct directly to the unit.

**⚠ WARNING**

For vertical supply and return units, tools or parts could drop into ductwork and cause an injury. Install a 90-degree turn in the return ductwork between the unit and the conditioned space. If a 90-degree elbow cannot be installed, then a grille of sufficient strength and density should be installed to prevent objects from falling into the conditioned space.

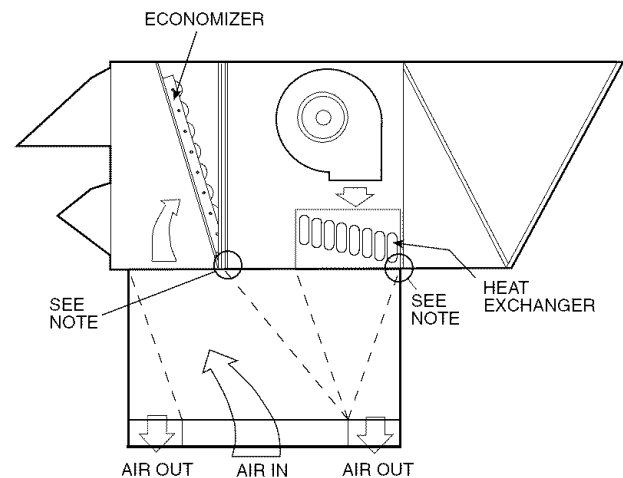
**HORIZONTAL APPLICATIONS** — Horizontal units are shipped with outer panels that allow for side by side horizontal duct connections. If specified during ordering, the unit will be shipped with the vertical duct openings blocked off from the factory, ready for side supply installation. If the horizontal supply/return option was not specified at time of ordering the unit, a field-installed accessory kit is required to convert the vertical unit into a horizontal supply configuration.

Installation of the duct block-off covers should be completed prior to placing the unit unless sufficient side clearance is available. A minimum of 66 in. is required between the unit and any obstruction to install the duct block-off covers. Side supply duct dimensions and locations are shown on Fig. 4. Install ductwork to horizontal duct flange connections on side of unit.



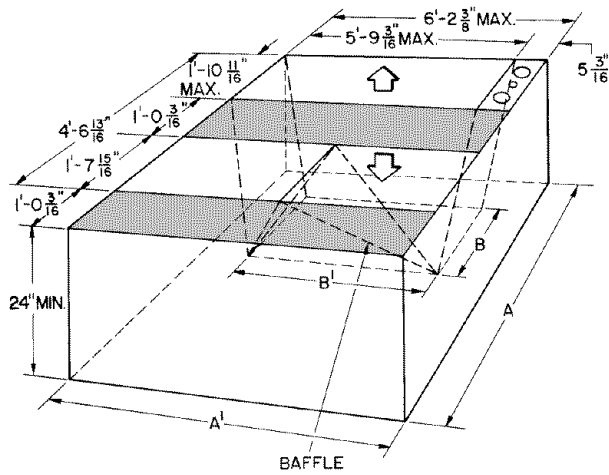
NOTE: Do not drill in this area; damage to basepan may result in water leak.

**Fig. 7 — Air Distribution — Vertical Supply/Return**



NOTE: Do not drill in this area; damage to basepan may result in water leak.

**Fig. 8 — Air Distribution — Concentric Duct**



NOTE: Dimensions A, A', B, and B' are obtained from field-supplied ceiling diffuser.

Shaded areas indicate block-off pans.

**Fig. 9 — Concentric Duct Details**

**Step 6 — Install Flue Hood and Inlet Hood —**

Flue hood (smaller hood), inlet hood (larger hood), and screens are shipped inside the unit in the fan section. To install, remove the heat panel. The flue hood is attached to the heat section panel from the outside using the screws provided. See Fig. 10.

The inlet hood is installed by inserting the hood through the back of the heat panel. Attach the hood by inserting the screws provided through the clearance holes in the heat panel and into the intake hood.

Install the screens into both hoods using the screws and retaining nuts provided with the unit.

Attach the cover of the observation hole on the intake hood and then replace the heat panel onto the unit to complete the installation.

NOTE: When properly installed, the flue hood will line up with the combustion fan housing. See Fig. 11.

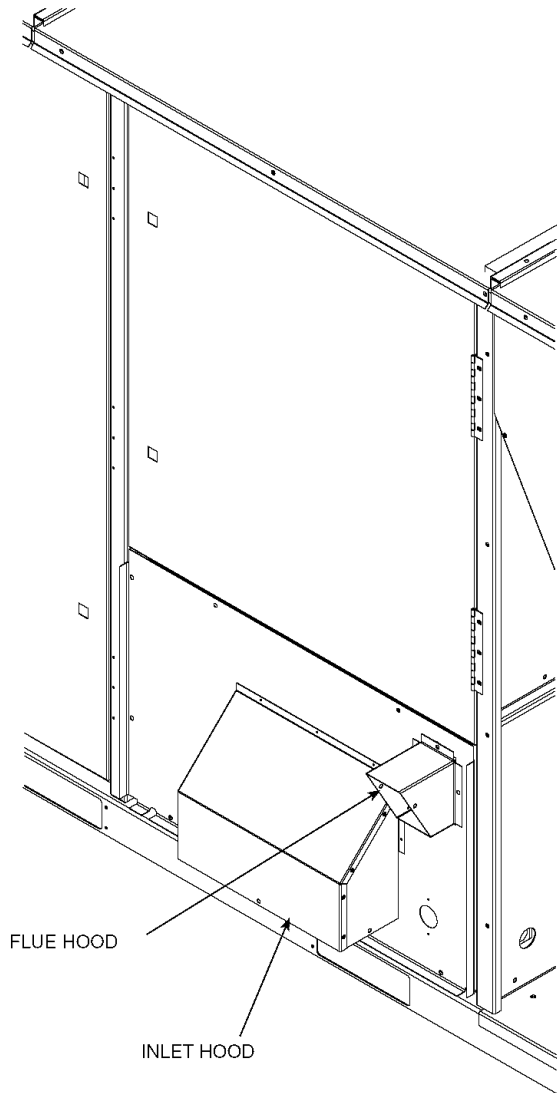
**Step 7 — Trap Condensate Drain —** See Fig. 12 for drain location. One 3/4-in. half coupling is provided outside unit evaporator section for condensate drain connection. A trap at least 4-in. deep must be used. See Fig. 13.

All units must have an external trap for condensate drainage. Install a trap at least 4 in. deep and protect against freeze-up. If drain line is installed downstream from the external trap, pitch the line away from the unit at 1 in. per 10 ft of run. Do not use a pipe size smaller than the unit connection.

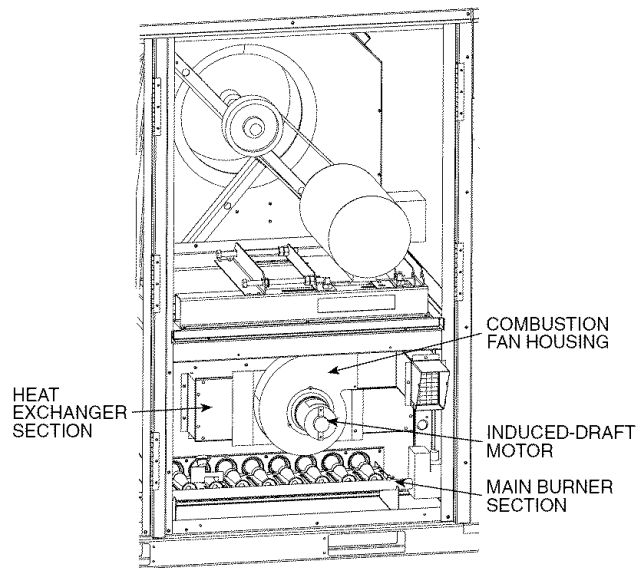
**Step 8 — Install Gas Piping —** Unit is equipped for use with natural gas. Refer to local building codes, or in the absence of local codes, to ANSI Z223.1-latest year and addendum Z223.1A-latest year entitled NFGC. In Canada, installation must be in accordance with the CAN1.B149.1 and CAN1.B149.2 installation codes for gas burning appliances.

Support gas piping. For example, a 3/4-in. gas pipe must have one field-fabricated support beam every 8 ft. Therefore, an 18-ft long gas pipe would have a minimum of 3 support beams.

Install field-supplied manual gas shutoff valve with a 1/8-in. NPT pressure tap for test gage connection at unit. The pressure tap is located on the gas manifold, adjacent to the gas valve. Field gas piping must include sediment trap and union. See Fig. 14.



**Fig. 10 — Flue and Inlet Hood Locations**



**Fig. 11 — Combustion Fan Housing Location**

### ▲ WARNING

Do not pressure test gas supply while connected to unit. Always disconnect union before servicing. A hazardous condition could occur resulting in serious injury.

**IMPORTANT:** Natural gas pressure at unit gas connection must not be less than 5.5 in. wg or greater than 13.0 in. wg.

Size gas-supply piping for 0.5-in. wg maximum pressure drop. Do not use supply pipe smaller than unit gas connection.

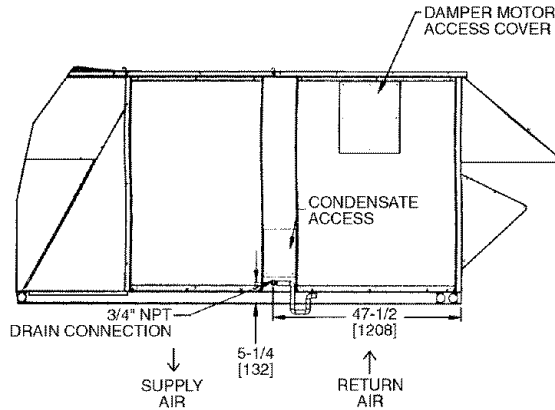
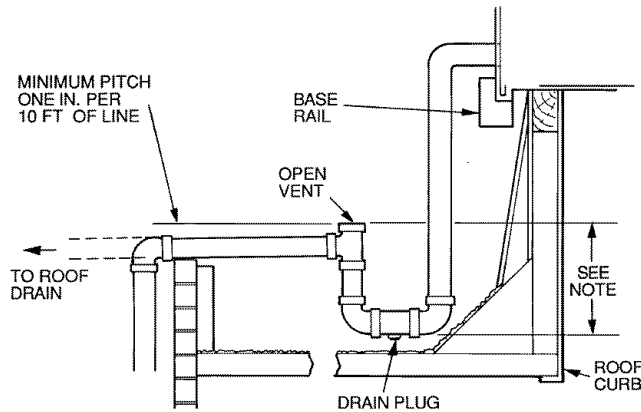


Fig. 12 — Condensate Drain Details



NOTE: Trap should be deep enough to offset maximum unit static difference. A 4-in. trap is recommended.

Fig. 13 — Condensate Drain Piping Details

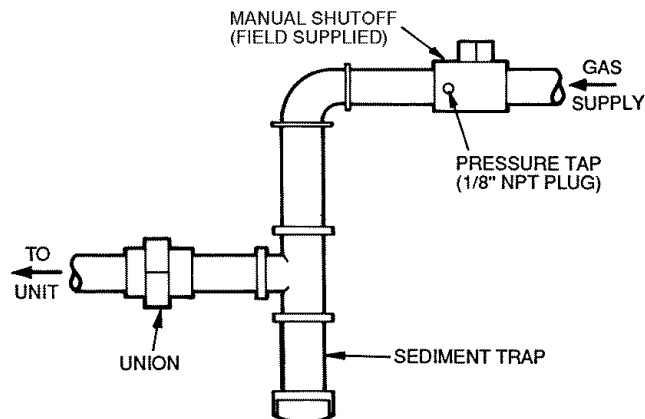


Fig. 14 — Field Gas Piping

## Step 9 — Make Electrical Connections

**FIELD POWER SUPPLY** — Unit is factory wired for voltage shown on unit nameplate. Be sure to check for correct voltage.

When installing units, provide disconnect per NEC (National Electrical Code) of adequate size (MOCP [Maximum Overcurrent protection] of unit is on the informative plate). See Tables 4A and 4B. All field wiring must comply with NEC and local codes. Size wire based on MCA (Minimum Circuit Amps) on the unit informative plate. See Fig. 15 for power wiring connection to the unit power terminal block and equipment ground.

Route power and ground lines through control box end panel or unit basepan (see Fig. 4) to connections as shown on unit wiring diagram and Fig. 15.

### ▲ CAUTION

The correct power phasing is critical to the operation of the scroll compressors. An incorrect phasing will result in compressor shutdown on thermal overload and possible damage to compressor. Should this occur, power phase correction must be made to the incoming power.

### ▲ WARNING

Unit cabinet must have an uninterrupted, unbroken electrical ground to minimize the possibility of personal injury if an electrical fault should occur. This ground may consist of electrical wire connected to unit ground lug in control compartment, or conduit approved for electrical ground when installed in accordance with NEC, ANSI/NFPA (National Fire Protection Association), latest edition, and local electrical codes. *Do not use gas piping as an electrical ground.* Failure to follow this warning could result in the installer being liable for personal injury of others.

Field wiring must conform to temperature limitations for type "T" wire. All field wiring must comply with NEC and local requirements.

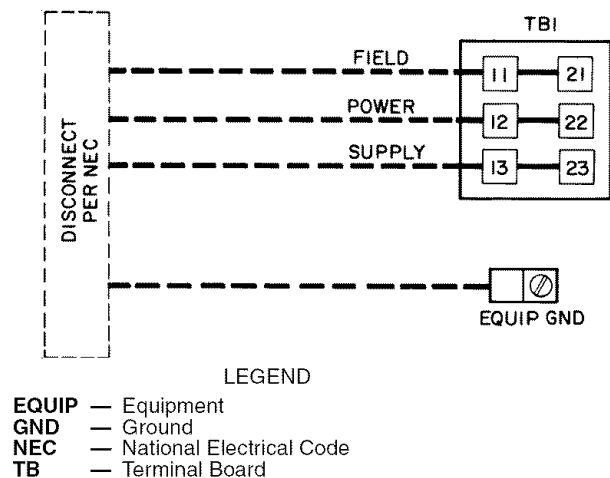
Operating voltage to compressor must be within voltage range indicated on unit nameplate. On 3-phase units, voltages between phases must be balanced within 2%.

Unit failure as a result of operation on improper line voltage or excessive phase imbalance constitutes abuse and may cause damage to electrical components.

**FIELD CONTROL WIRING** — Unit can be controlled with a Carrier-approved accessory thermostat. Install thermostat according to the installation instructions included with accessory. Locate thermostat assembly on a solid interior wall in the conditioned space to sense average temperature.

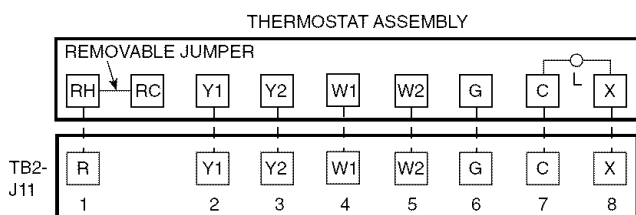
Route thermostat cable or equivalent single leads of colored wire from subbase terminals through conduit into unit to low-voltage connections as shown on unit label wiring diagram and in Fig. 16.

NOTE: For wire runs up to 50 ft, use no. 18 AWG (American Wire Gage) insulated wire (35 C minimum). For 50 to 75 ft, use no. 16 AWG insulated wire (35 C minimum). For over 75 ft, use no. 14 AWG insulated wire (35 C minimum). All wire larger than no. 18 AWG cannot be directly connected at the thermostat and will require a junction box and splice at the thermostat.



NOTE: The maximum wire size for TB1 is 2/0.

**Fig. 15 — Field Power Wiring Connections**



**Fig. 16 — Field Control Thermostat Wiring**

Set heat anticipator settings as follows:

VOLTAGE	STAGE 1 (W1) ON	STAGE 1 AND 2 (W1 AND W2) ON
All	0.15	0.30

Settings may be changed slightly to provide a greater degree of comfort for a particular installation.

**Step 10 — Install Outdoor Air Hood —** Perform the following procedure to install the outdoor-air hood on units equipped with an economizer, two-position damper, or manual outdoor air damper:

1. Remove blank panel from return end of unit (hood section). Save the screws. See Fig. 17 for shipping location of components.
2. Hood sides are fastened to sides of outdoor air opening. Remove the hood sides and save the screws (3 each side).
3. Remove the bracket holding the bottom half of the hood in the shipping position. Remove the hood bottom half and filters (or manual dampers on units so equipped) from outdoor section.

NOTE: On units without economizers, the components are attached to the unit basepan. To access the components, remove the panel below the outdoor air intake section.

4. Remove inner filter track from shipping position in outdoor section. Position inner filter track so the track is facing outward from the unit. Install the filter track with 4 screws provided.

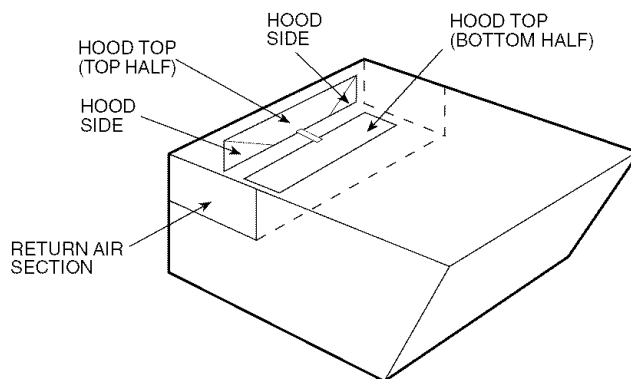
5. Apply seal strip (provided) to back flange of both hood sides where hood side connects to the unit back panel. See Fig. 18.
6. Apply seal strip (provided) to top flange of both hood sides where hood sides connect to the hood top panels. See Fig. 18.
7. Install hood sides to the back panels using the screws from Step 2. The sloped flanges point outward. The drip edges of the side panels should face outward as well. Attach the filter guides to the hood sides. The flanges of the filter guides should face inward to hold the filters in place. See Fig. 18.
8. Apply seal strip along the entire length of the bottom flange of the hood top. See Fig. 18.
9. Install the bottom part of the hood top using 4 screws provided. See Fig. 18.
10. Remove the packaging from filters (3) and install into the filter tracks. Slide the filters to the sides then place the last filter into the center of the filter track.

NOTE: For units with manual dampers, replace the end filters with the manual dampers. Install the filter in the center between the manual dampers.

11. Install the filter retainer track along the bottom edge of the outdoor air hood using 4 screws provided. See Fig. 18.
12. Install top section of the outdoor air hood using 9 screws provided. See Fig. 18. See Fig. 19 for a picture of the assembled outdoor air hood.

NOTE: For filter removal, remove the four screws holding the filter retainer. The filters can then be removed, cleaned, or replaced. Install the filters by reversing the procedure.

**MANUAL DAMPER ASSEMBLY —** For units equipped with manual dampers, the assembly process is similar to the outdoor air hood for units with economizers. There are two slide dampers shipped with the unit to allow for manual setting of the outside air volume. When assembling the hood, place one of the manual slide dampers in each of the end positions and the remaining filter in the center position. The manual dampers can then be moved to the appropriate position and then locked into place using the screws mounted in the adjustment slots. See Fig. 20.



**Fig. 17 — Outdoor-Air Hood Component Shipping Location**

Table 4A — Electrical Data — Units Without Convenience Outlet

UNIT 48HJ	NOMINAL VOLTAGE (3 Ph, 60 Hz)	VOLTAGE RANGE		COMPRESSOR						OFM			IFM		POWER EXHAUST			COMBUSTION FAN MOTOR	POWER SUPPLY			DISCONNECT SIZE
				No. 1		No. 2		No. 3							Qty	Hp	FLA (ea)		Qty	Hp	FLA (ea)	
				RLA	LRA	RLA	LRA	RLA	LRA	Min	Max											
020	208/230	187	253	16.7	130	16.7	130	22.4	184	4	0.25	1.5	3.7	10.6/ 9.6	2	1	5.9	0.5	78/ 77	100/ 90	83/ 82	
													5	16.7/15.2	2	1	5.9		90/ 89	100/100	97/ 96	
													7.5	24.2/22	2	1	5.9		84/ 83	100/100	90/ 89	
													2	1	5.9	96/ 94	100/100		104/102			
													2	1	5.9	92/ 89	100/100		99/ 96			
													2	1	5.9	104/101	125/110		112/110			
	460	414	506	9	70	9	70	10.7	90	4	0.25	0.7	3.7	4.8	2	1	3.1	0.3	39	45	42	
													5	7.6	2	1	3.1		45	50	49	
													7.5	11	2	1	3.1		42	50	45	
													2	1	3.1	48	50		52			
													2	1	3.1	45	50		49			
													2	1	3.1	51	60		56			
575	518	633	7	55	7	55	9.3	73	4	0.25	0.7	3	3.9	2	1	2.4	0.24	32	40	35		
												5	6.1	2	1	2.4		37	45	40		
												7.5	9	2	1	2.4		35	40	37		
												2	1	2.4	39	45		43				
												2	1	2.4	37	45		40				
												2	1	2.4	47	50		46				
024	208/230	187	253	22.4	184	22.4	184	22.4	184	4	0.25	1.5	3.7	10.6/ 9.6	2	1	5.9	0.5	89/ 88	100/100	96/ 95	
													5	16.7/15.2	2	1	5.9		101/100	110/110	110/109	
													7.5	24.2/22	2	1	5.9		96/ 94	100/100	103/102	
													2	1	5.9	107/106	125/125		117/115			
													2	1	5.9	103/101	125/110		112/109			
													2	1	5.9	115/113	125/125		128/123			
	460	414	506	10.7	90	10.7	90	10.7	90	4	0.25	0.7	3.7	4.8	2	1	3.1	0.3	42	50	46	
													5	7.6	2	1	3.1		49	50	53	
													7.5	11	2	1	3.1		45	50	49	
													2	1	3.1	51	60		56			
													2	1	3.1	49	50		53			
													2	1	3.1	55	60		60			
575	518	633	9.3	73	9.3	73	9.3	73	4	0.25	0.7	5	6.1	2	1	2.4	0.24	52	60	56		
												7.5	9	2	1	2.4		59	60	63		
												2	1	2.4	39	45		42				
												2	1	2.4	44	50		48				
												2	1	2.4	42	50		46				
												2	1	2.4	47	50		51				
028	208/230	187	253	47.1	245	47.1	245	—	—	6	0.25	1.5	5	16.7/15.2	2	1	5.9	0.5	132/130	175/175	138/136	
													7.5	24.2/22	2	1	5.9		143/142	175/175	151/150	
													10	30.8/28	2	1	5.9		139/137	175/175	147/144	
													2	1	5.9	151/149	175/175		160/158			
													2	1	5.9	146/143	175/175		154/151			
													2	1	5.9	158/155	200/200		168/164			
	460	414	506	19.6	125	19.6	125	—	—	6	0.25	0.7	5	7.6	2	1	3.1	0.3	56	60	59	
													7.5	11	2	1	3.1		62	80	66	
													10	14	2	1	3.1		59	60	63	
													2	1	3.1	66	80		70			
													2	1	3.1	62	80		66			
													2	1	3.1	69	80		73			
575	518	633	15.8	100	15.8	100	—	—	6	0.25	0.7	5	6.1	2	1	2.4	0.24	46	60	48		
												7.5	9	2	1	2.4		51	60	54		
												10	11	2	1	2.4		49	60	52		
												2	1	2.4	54	60		57				
												2	1	2.4	51	60		54				
												2	1	2.4	56	60		59				

See Legend and Notes on page 15.

Table 4B — Electrical Data — Units With Optional Convenience Outlet

UNIT 48HJ	NOMINAL VOLTAGE (3 Ph, 60 Hz)	VOLTAGE RANGE		COMPRESSOR						OFM			IFM		POWER EXHAUST			COMBUSTION FAN MOTOR	POWER SUPPLY			DISCONNECT SIZE
				No. 1		No. 2		No. 3							Qty	Hp	FLA (ea)		Qty	Hp	FLA (ea)	
		Min	Max	RLA	LRA	RLA	LRA	RLA	LRA	Qty	Hp	FLA (ea)	FLA	MCA				MOCP*				FLA
020	208/230	187	253	16.7	130	16.7	130	22.4	184	4	0.25	1.5	3.7	10.6/ 9.6	—	—	—	0.5	83/ 82	100/100	89/ 88	
													2	1	5.9	95/ 94	100/100		103/101			
													5	16.7/15.2	—	—	—		89/ 88	100/100	96/ 94	
													2	1	5.9	101/ 99	110/100		110/108			
													7.5	24.2/22	—	—	—		97/ 94	100/100	105/102	
													2	1	5.9	109/106	125/125		118/116			
	3.7	4.8	—	—	—	42	50	45														
	5	7.6	—	—	—	48	50	52														
	2	1	3.1	45	50	48																
	7.5	11	—	—	—	51	60	56														
	2	1	3.1	48	50	52																
	5	6.1	—	—	—	54	60	59														
2	1	2.4	35	40	38																	
7.5	9	—	—	—	40	45	43															
2	1	2.4	38	45	40																	
2	1	2.4	42	50	46																	
2	1	2.4	40	45	44																	
2	1	2.4	45	50	49																	
024	208/230	187	253	22.4	184	22.4	184	22.4	184	4	0.25	1.5	3.7	10.6/ 9.6	—	—	—	0.5	94/ 93	100/100	102/101	
													2	1	5.9	106/105	125/125		116/115			
													5	16.7/15.2	—	—	—		101/ 99	110/100	109/107	
													2	1	5.9	112/111	125/125		123/121			
													7.5	24.2/22	—	—	—		108/106	125/125	118/115	
													2	1	5.9	120/118	125/125		131/129			
	3.7	4.8	—	—	—	45	50	49														
	5	7.6	—	—	—	52	60	56														
	2	1	3.1	48	50	52																
	7.5	11	—	—	—	54	60	59														
	2	1	3.1	52	60	56																
	10	14	—	—	—	55	60	60														
	2	1	3.1	62	70	67																
	5	6.1	—	—	—	42	50	46														
	2	1	2.4	47	50	51																
	7.5	9	—	—	—	45	50	49														
	2	1	2.4	50	50	55																
	10	11	—	—	—	47	50	51														
2	1	2.4	52	60	57																	
028	208/230	187	253	47.1	245	47.1	245	—	—	6	0.25	1.5	5	16.7/15.2	—	—	—	0.5	137/135	175/175	144/142	
													2	1	5.9	148/147	175/175		157/155			
													7.5	24.2/22	—	—	—		144/142	175/175	152/150	
													2	1	5.9	156/154	200/200		166/163			
													10	30.8/28	—	—	—		151/148	175/175	160/157	
													2	1	5.9	163/160	200/200		173/170			
	5	7.6	—	—	—	59	60	62														
	2	1	3.1	65	80	69																
	7.5	11	—	—	—	62	80	66														
	2	1	3.1	69	80	73																
	10	14	—	—	—	65	80	69														
	2	1	3.1	72	90	77																
5	6.1	—	—	—	49	60	52															
2	1	2.4	54	60	57																	
7.5	9	—	—	—	52	60	55															
2	1	2.4	57	60	60																	
10	11	—	—	—	54	60	57															
2	1	2.4	59	60	63																	

## LEGEND AND NOTES FOR TABLES 4A AND 4B

### LEGEND

- FLA** — Full Load Amps
- HACR** — Heating, Air Conditioning and Refrigeration
- IFM** — Indoor (Evaporator) Fan Motor
- LRA** — Locked Rotor Amps
- MCA** — Minimum Circuit Amps
- MOCP** — Maximum Overcurrent Protection
- OFM** — Outdoor (Condenser) Fan Motor
- RLA** — Rated Load Amps

\*Fuse or HACR circuit breaker.

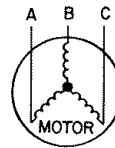


### NOTES:

1. In compliance with NEC (National Electric Code) requirements for multimotor and combination load equipment (refer to NEC Articles 430 and 440), the overcurrent protective device for the unit shall be fuse or HACR breaker. Canadian units may be fuse or circuit breaker.
2. **Unbalanced 3-Phase Supply Voltage**  
*Never operate a motor where a phase imbalance in supply voltage is greater than 2%.* Use the following formula to determine the percent voltage imbalance.

$$\% \text{ Voltage Imbalance} = 100 \times \frac{\text{max voltage deviation from average voltage}}{\text{average voltage}}$$

EXAMPLE: Supply voltage is 460-3-60.



$$\begin{aligned} AB &= 452 \text{ v} \\ BC &= 464 \text{ v} \\ AC &= 455 \text{ v} \\ \text{Average Voltage} &= \frac{452 + 464 + 455}{3} \\ &= \frac{1371}{3} \\ &= 457 \end{aligned}$$

Determine maximum deviation from average voltage.

$$\begin{aligned} (AB) &457 - 452 = 5 \text{ v} \\ (BC) &464 - 457 = 7 \text{ v} \\ (AC) &457 - 455 = 2 \text{ v} \end{aligned}$$

Maximum deviation is 7 v.

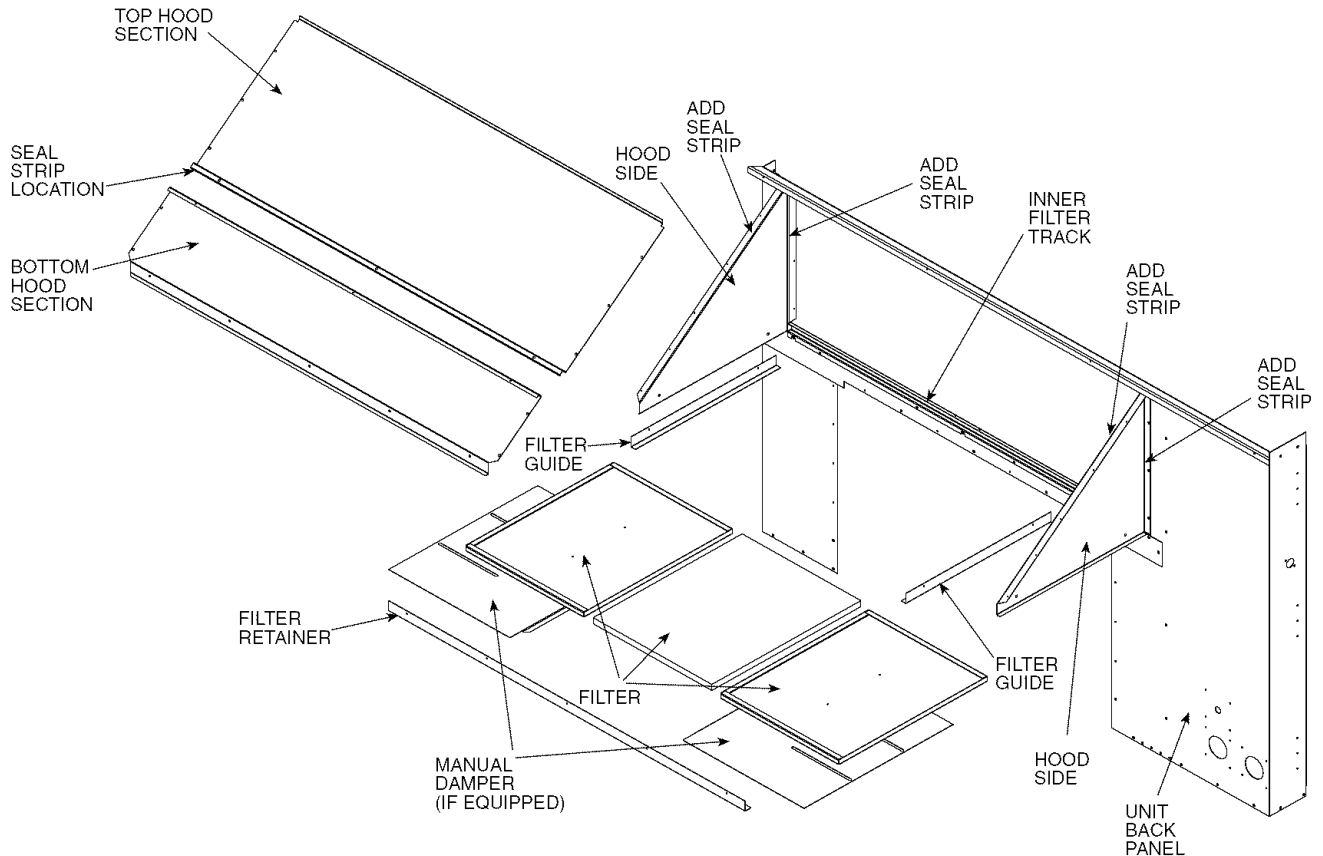
Determine percent voltage imbalance.

$$\begin{aligned} \% \text{ Voltage Imbalance} &= 100 \times \frac{7}{457} \\ &= 1.53\% \end{aligned}$$

This amount of phase imbalance is satisfactory as it is below the maximum allowable 2%.

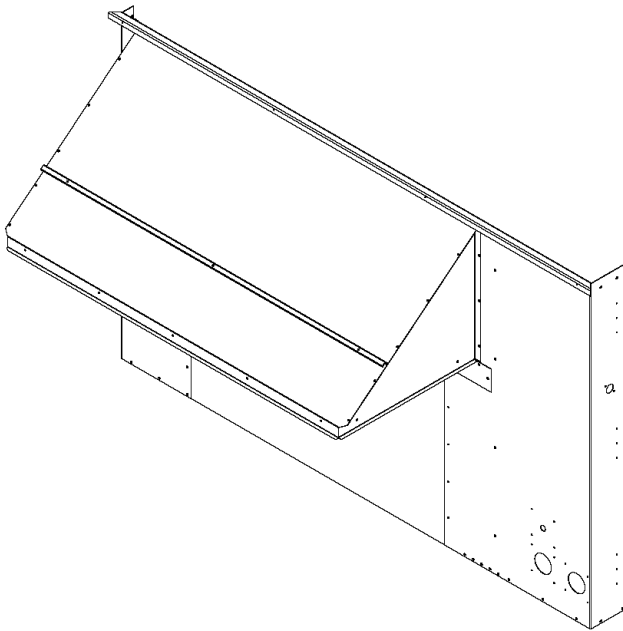
**IMPORTANT:** If the supply voltage phase imbalance is more than 2%, contact your local electric utility company immediately.

3. The convenience outlet full load amps (FLA) are 5, 3, and 3 for 208/230, 460, 575-V units, respectively.

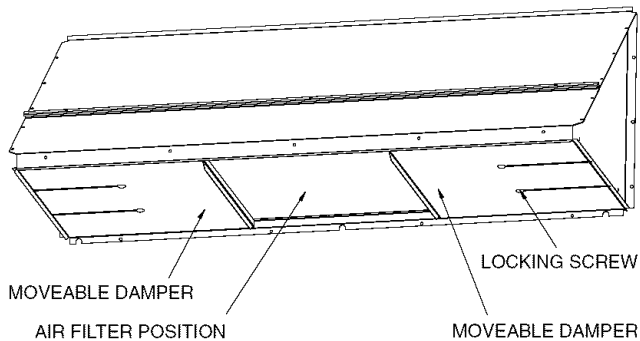


NOTE: Units with manual damper only use one filter.

**Fig. 18 — Outdoor-Air Hood Details**



**Fig. 19 — Outdoor-Air Hood Assembled**



**Fig. 20 — Manual Damper Details**

**Step 11 — Position Optional Power Exhaust or Barometric Relief Damper Hood —**

The optional power exhaust or barometric relief dampers are shipped assembled and tilted back into the unit for shipping. Brackets and extra screws are shipped in shrink wrap around the dampers.

1. Remove 9 screws holding each damper assembly in place. See Fig. 21. Each damper assembly is secured with 3 screws on each side and 3 screws along the bottom. Save screws.

**⚠ CAUTION**

Use care when tilting blower assembly. Hoods and blowers are heavy and can cause injury if dropped.

2. Pivot the damper assembly outward until top edge of the damper assembly rests against the inside wall of unit.
3. Secure each damper assembly to unit with 6 screws across top (3 screws provided) and bottom (3 screws from Step 1) of damper.
4. With screws saved from Step 1, install brackets on each side of damper assembly. See Fig. 22.
5. Remove tape from damper blades.

**Step 12 — Non-Fused Disconnect —** The handle for the factory-installed non-fused disconnect is shipped inside the unit to prevent the handle from damage during shipping. Follow these steps to complete installation of the handle.

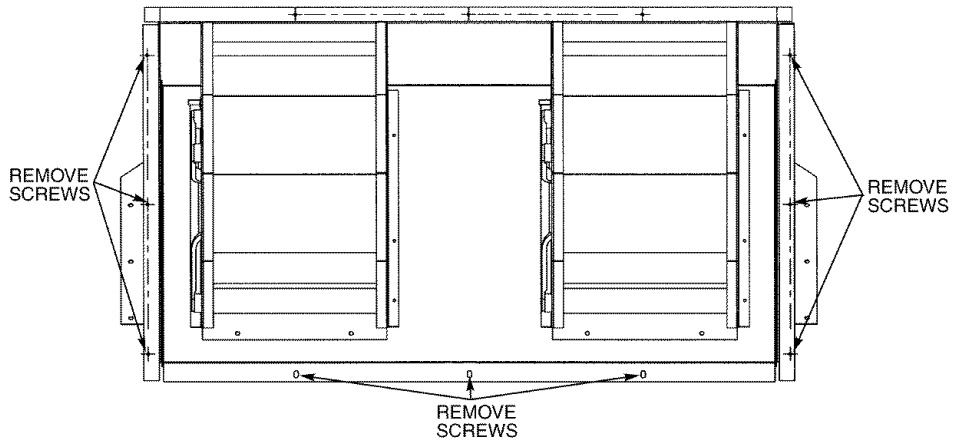
**⚠ WARNING**

Be sure power is shut off to the unit from the building power supply. Electrical shock could cause serious personal injury.

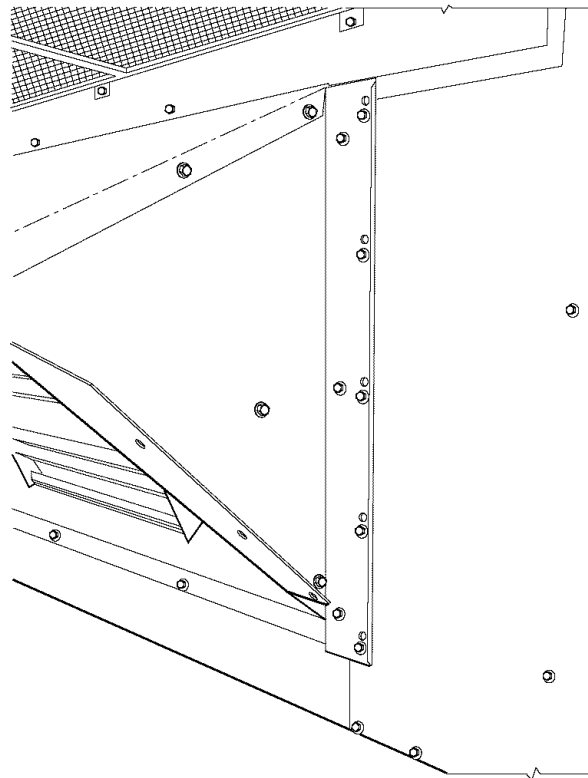
1. Open the control box access door.
2. Remove the small cover plate located on the unit corner post near the control section.
3. Remove the inner control box cover. The handle and shaft are located in a plastic bag at the bottom of the control box.
4. Insert the square shaft into the disconnect with the pins vertical. On the 100-amp disconnect, the shaft is keyed into the disconnect and can only be installed one way (with the pins vertical).
5. Insert the handle through the corner post and onto the shaft with the handle positioned so that “OFF” is on top.
6. Rotate the handle to the “ON” position to lock the pins into the handle.
7. From the inside of the corner post, attach the handle mounting screws to the handle. Slide the shaft fully into the handle and tighten the set screw(s) on the disconnect to lock the shaft. Tighten the screws that attach the handle to the corner post.
8. Rotate the handle back to the “OFF” position.
9. Replace all panels and doors. Power can now be turned back on to the unit.

**Step 13 — Install All Accessories —** After all of the factory-installed options have been adjusted, install all field-installed accessories. Refer to the accessory installation instructions included with each accessory. Consult the Carrier Price Pages for accessory package numbers for particular applications.





**Fig. 21 — Power Exhaust or Barometric Relief Damper Mounting Details**



**Fig. 22 — Bracket and Hood Positioning**

## PRE-START-UP

### ▲ WARNING

Failure to observe the following warnings could result in serious personal injury.

1. Follow recognized safety practices and wear protective goggles when checking or the servicing refrigerant system.
2. Do not operate the compressor or provide any electric power to the unit unless the compressor terminal cover is in place and secured.
3. Do not remove the compressor terminal cover until all electrical sources are disconnected.
4. Relieve all pressure from the system before touching or disturbing anything inside the compressor terminal box if refrigerant leak is suspected around the compressor terminals.
5. Never attempt to repair a soldered connection while the refrigerant system is under pressure.
6. Do not use torch to remove any component. The system contains oil and refrigerant under pressure. To remove a component, wear protective goggles and proceed as follows:
  - a. Shut off gas and then electrical power to the unit. Install lockout tag.
  - b. Relieve all pressure from the system using both high-pressure and low-pressure ports.
  - c. Cut the component connection tubing with a tubing cutter, and remove the component from the unit.
  - d. Carefully unsweat the remaining tubing stubs when necessary. Oil can ignite when exposed to torch flame.

Proceed as follows to inspect and prepare the unit for initial start-up:

1. Remove all access panels.
2. Read and follow instructions on all WARNING, CAUTION, and INFORMATION labels attached to, or shipped with, the unit.
3. Make the following inspections:
  - a. Inspect for shipping and handling damages such as broken lines, loose parts, or disconnected wires, etc.
  - b. Inspect for oil at all refrigerant tubing connections and on unit base. Detecting oil generally indicates a refrigerant leak. Leak-test all refrigerant tubing connections using an electronic leak detector, halide torch, or liquid-soap solution.
  - c. Inspect all field-wiring and factory-wiring connections. Be sure that connections are completed and tight.
  - d. Inspect coil fins. If damaged during shipping and handling, carefully straighten the fins with a fin comb.
4. Verify the following conditions:
  - a. Make sure that condenser fan blade is correctly positioned in the fan orifice. See Condenser-Fan Adjustment section on page 47 for more details.
  - b. Make sure that air filter(s) is in place.
  - c. Make sure that condensate drain trap is filled with water to ensure proper drainage.
  - d. Make sure that all tools and miscellaneous loose parts have been removed.

## START-UP

Use the following information and Start-Up Checklist on page CL-1 to check out unit PRIOR to start-up.

**Unit Preparation** — Check that unit has been installed in accordance with these installation instructions and all applicable codes.

**Compressor Mounting** — Compressors are internally spring mounted. Do not loosen or remove compressor hold-down bolts.

**Refrigerant Service Ports** — Each independent refrigerant system has a total of 3 Schrader-type service gage ports per circuit. One port is located on the suction line, one on the compressor discharge line, and one on the liquid line. Be sure that caps on the ports are tight.

**Crankcase Heater(s)** — Crankcase heaters are energized as long as there is power to the unit and the compressor is not operating.

**IMPORTANT:** Unit power must be on for 24 hours prior to start-up. Otherwise, damage to compressor may result.

### Compressor Phasing

#### ▲ CAUTION

Improper wiring will cause compressor stoppage and may cause equipment damage. Correct wiring by switching leads as indicated below.

On 3-phase units, it is important to be certain the compressors are rotating in the proper direction. To determine whether or not compressors are rotating in the proper direction, use a phase-rotation meter on the unit input power to check for L1-L2-L3 or clockwise rotation. If the compressor is rotating in the wrong direction, the suction pressure will not drop and the discharge pressure will not rise.

**NOTE:** Indoor or outdoor fan rotation direction may not indicate proper input power phase sequence, as some 3-phase units use single-phase fan motors. Check fan rotation where applicable.

To correct the wrong compressor rotation direction, perform the following procedure:

1. Turn off power to the unit and lock out the power.
2. Switch any two of the incoming unit power leads.
3. Turn on power to the unit.
4. Verify corrected compressor rotation and fan rotation where applicable.

**Internal Wiring** — Check all electrical connections in unit control boxes; tighten as required.

**Evaporator Fan** — Fan belt and variable pulleys are factory-installed. See Tables 5-23 for fan performance data. Be sure that fans rotate in the proper direction. See Table 24 for air quantity limits. See Table 25 for evaporator fan motor specifications. See Table 26 for accessory or factory-installed options static pressure. See Table 27 for fan rpm at various motor pulley settings. To alter fan performance, see Evaporator Fan Performance Adjustment section on page 47.

**Condenser Fans and Motors** — Condenser fans and motors are factory set. Refer to Condenser-Fan Adjustment section (page 47) as required.

**Return-Air Filters** — Check that correct filters are installed in filter tracks (see Table 1). Do not operate unit without return-air filters.

NOTE: For units with 4-in. filter option, units are shipped with standard 2-in. filters. To install 4-in. filters, the filter spacers must be removed.

**Outdoor-Air Inlet Screens** — Outdoor-air inlet screens must be in place before operating unit.

**Gas Heat** — Verify gas pressures before turning on heat as follows:

1. Turn off field-supplied manual gas stop, located external to unit.

2. Connect pressure gage to supply gas tap, located on field-supplied manual shutoff valve (see Fig. 14).
3. Connect pressure gage to manifold pressure tap.
4. Turn on field-supplied manual gas stop. Provide a call for heating stage 1.
5. After the unit has run for several minutes, verify the supply gas pressure is between 5.5 in. wg and 13.0 in. wg. Provide a call for heating stage 2. Check manifold pressure after 5 minutes of stage 2 operation. Manifold pressure should be 3.00 in. wg. If manifold pressure must be adjusted, refer to Gas Valve Adjustment section.

NOTE: Supply gas pressure must not exceed 13.0 in. wg.

6. Turn off unit.
7. Remove call for heat.

**Table 5 — Fan Performance — 48HJD020 Vertical Discharge Units\***

AIRFLOW (Cfm)	AVAILABLE EXTERNAL STATIC PRESSURE (in. wg)														
	0.2			0.4			0.6			0.8			1.0		
	Rpm	Watts	Bhp	Rpm	Watts	Bhp	Rpm	Watts	Bhp	Rpm	Watts	Bhp	Rpm	Watts	Bhp
3500	460	591	0.68	548	774	0.89	623	951	1.09	692	1126	1.29	755	1301	1.50
4000	499	774	0.89	581	976	1.12	653	1170	1.35	717	1361	1.56	777	1551	1.78
4500	538	990	1.14	617	1212	1.39	685	1423	1.64	746	1630	1.88	803	1835	2.11
5000	579	1243	1.43	654	1485	1.71	719	1715	1.97	778	1938	2.23	832	2158	2.48
5500	621	1536	1.77	693	1798	2.07	755	2045	2.35	811	2285	2.63	864	2520	2.90
6000	664	1871	2.15	732	2152	2.48	792	2417	2.78	846	2673	3.07	897	2925	3.36
6500	707	2250	2.59	772	2550	2.93	830	2834	3.26	883	3106	3.57	932	3373	3.88
7000	751	2676	3.08	813	2994	3.44	869	3295	3.79	920	3585	4.12	967	3868	4.45
7500	795	3150	3.62	855	3487	4.01	909	3805	4.38	958	4112	4.73	1004	4411	5.07
8000	839	3676	4.23	897	4029	4.63	949	4366	5.02	997	4689	5.39	1042	5004	5.75
8500	884	4253	4.89	940	4625	5.32	990	4978	5.73	1037	5318	6.12	1080	5649	6.50

AIRFLOW (Cfm)	AVAILABLE EXTERNAL STATIC PRESSURE (in. wg)														
	1.2			1.4			1.6			1.8			2.0		
	Rpm	Watts	Bhp	Rpm	Watts	Bhp	Rpm	Watts	Bhp	Rpm	Watts	Bhp	Rpm	Watts	Bhp
3500	814	1476	1.70	871	1650	1.90	924	1825	2.10	975	1999	2.30	1023	2173	2.50
4000	834	1740	2.00	888	1930	2.22	939	2119	2.44	988	2308	2.65	1035	2497	2.87
4500	857	2039	2.35	909	2243	2.58	958	2446	2.81	1005	2650	3.05	1051	2853	3.28
5000	884	2376	2.73	933	2594	2.98	980	2811	3.23	1026	3028	3.48	1070	3244	3.73
5500	913	2753	3.17	960	2984	3.43	1006	3215	3.70	1049	3445	3.96	1092	3674	4.23
6000	945	3172	3.65	990	3417	3.93	1034	3662	4.21	1076	3905	4.49	1117	4147	4.77
6500	978	3636	4.18	1022	3895	4.48	1064	4153	4.78	1104	4409	5.07	1144	4665	5.37
7000	1012	4145	4.77	1055	4419	5.08	1095	4691	5.39	1135	4960	5.70	1173	5229	6.01
7500	1047	4703	5.41	1089	4992	5.74	1128	5277	6.07	1167	5561	6.40	1204	5842	6.72
8000	1084	5311	6.11	1124	5615	6.46	1163	5915	6.80	1200	6211	7.14	1236	6506	7.48
8500	1121	5972	6.87	1160	6290	7.23	1198	6604	7.60	1234	6914	7.95	1269	7223	8.31

**LEGEND**

**Bhp** — Brake Horsepower Input to Fan  
**Watts** — Input Watts to Motor

\*Motor drive ranges:  
 Low Range: Not Used  
 Mid-Low Range: 647-886 (208/230 and 460-v), 810-1072 (575-v)  
 Mid-High Range: 897-1139 (208/230 and 460-v), 873-1108 (575-v)  
 High Range: 1078-1274  
 All other rpms require field-supplied drive.

Refer to page 27 for general Fan Performance Data notes.

NOTE: Maximum continuous bhp is:  
 Low Range: Not Used  
 Mid-Low Range: 4.25 (208/230 and 460-v), 3.45 (575-v)  
 Mid-High Range: 5.75  
 High Range: 8.63

**Table 6 — Fan Performance — 48HJE020 Vertical Discharge Units\***

AIRFLOW (Cfm)	AVAILABLE EXTERNAL STATIC PRESSURE (in. wg)														
	0.2			0.4			0.6			0.8			1.0		
	Rpm	Watts	Bhp	Rpm	Watts	Bhp	Rpm	Watts	Bhp	Rpm	Watts	Bhp	Rpm	Watts	Bhp
3500	470	611	0.70	556	791	0.91	630	967	1.11	697	1141	1.31	760	1314	1.51
4000	511	802	0.92	591	1001	1.15	661	1194	1.37	725	1383	1.59	784	1572	1.81
4500	553	1029	1.18	629	1248	1.44	695	1458	1.68	756	1663	1.91	812	1866	2.15
5000	597	1297	1.49	669	1534	1.76	732	1761	2.03	789	1982	2.28	843	2201	2.53
5500	641	1606	1.85	709	1862	2.14	770	2106	2.42	825	2343	2.70	876	2577	2.96
6000	686	1961	2.26	751	2234	2.57	809	2495	2.87	862	2749	3.16	911	2997	3.45
6500	732	2363	2.72	794	2653	3.05	849	2931	3.37	900	3201	3.68	948	3465	3.99
7000	779	2815	3.24	837	3122	3.59	891	3416	3.93	940	3702	4.26	986	3981	4.58
7500	826	3320	3.82	882	3642	4.19	933	3953	4.55	980	4254	4.89	1025	4549	5.23
8000	873	3879	4.46	926	4217	4.85	975	4542	5.22	1021	4860	5.59	1065	5169	5.95
8500	921	4495	5.17	972	4847	5.57	1019	5189	5.97	1063	5521	6.35	1105	5846	6.72

AIRFLOW (Cfm)	AVAILABLE EXTERNAL STATIC PRESSURE (in. wg)														
	1.2			1.4			1.6			1.8			2.0		
	Rpm	Watts	Bhp	Rpm	Watts	Bhp	Rpm	Watts	Bhp	Rpm	Watts	Bhp	Rpm	Watts	Bhp
3500	818	1488	1.71	874	1661	1.91	927	1835	2.11	978	2008	2.31	1026	2182	2.51
4000	840	1760	2.02	893	1948	2.24	943	2136	2.46	992	2324	2.67	1039	2512	2.89
4500	865	2068	2.38	915	2270	2.61	964	2472	2.84	1011	2673	3.07	1056	2876	3.31
5000	893	2417	2.78	942	2632	3.03	988	2848	3.28	1033	3063	3.52	1076	3278	3.77
5500	925	2808	3.23	971	3037	3.49	1016	3266	3.76	1059	3494	4.02	1100	3721	4.28
6000	958	3243	3.73	1003	3486	4.01	1045	3728	4.29	1087	3970	4.57	1127	4210	4.84
6500	993	3725	4.28	1036	3982	4.58	1077	4238	4.87	1117	4492	5.17	1156	4745	5.46
7000	1029	4256	4.90	1071	4528	5.21	1111	4797	5.52	1150	5064	5.82	1187	5330	6.13
7500	1067	4838	5.56	1107	5124	5.89	1146	5407	6.22	1184	5688	6.54	1220	5967	6.86
8000	1106	5474	6.30	1145	5774	6.64	1182	6071	6.98	1219	6365	7.32	1254	6657	7.66
8500	1145	6165	7.09	1183	6479	7.45	1220	6790	7.81	1255	7098	8.16	1290	7403	8.51

**LEGEND**

**Bhp** — Brake Horsepower Input to Fan  
**Watts** — Input Watts to Motor

\*Motor drive ranges:  
 Low Range: Not Used  
 Mid-Low Range: 647-886 (208/230 and 460-v), 810-1072 (575-v)  
 Mid-High Range: 897-1139 (208/230 and 460-v), 873-1108 (575-v)  
 High Range: 1078-1274  
 All other rpms require field-supplied drive.

Refer to page 27 for general Fan Performance Data notes.

NOTE: Maximum continuous bhp is:  
 Low Range: Not Used  
 Mid-Low Range: 4.25 (208/230 and 460-v), 3.45 (575-v)  
 Mid-High Range: 5.75  
 High Range: 8.63

**Table 7 — Fan Performance — 48HJF020 Vertical Discharge Units\***

AIRFLOW (Cfm)	AVAILABLE EXTERNAL STATIC PRESSURE (in. wg)														
	0.2			0.4			0.6			0.8			1.0		
	Rpm	Watts	Bhp	Rpm	Watts	Bhp	Rpm	Watts	Bhp	Rpm	Watts	Bhp	Rpm	Watts	Bhp
3500	470	611	0.70	556	791	0.91	630	967	1.11	697	1141	1.31	760	1314	1.51
4000	511	802	0.92	591	1001	1.15	661	1194	1.37	725	1383	1.59	784	1572	1.81
4500	553	1029	1.18	629	1248	1.44	695	1458	1.68	756	1663	1.91	812	1866	2.15
5000	597	1297	1.49	669	1534	1.76	732	1761	2.03	789	1982	2.28	843	2201	2.53
5500	641	1606	1.85	709	1862	2.14	770	2106	2.42	825	2343	2.70	876	2577	2.96
6000	686	1961	2.26	751	2234	2.57	809	2495	2.87	862	2749	3.16	911	2997	3.45
6500	732	2363	2.72	794	2653	3.05	849	2931	3.37	900	3201	3.68	948	3465	3.99
7000	779	2815	3.24	837	3122	3.59	891	3416	3.93	940	3702	4.26	986	3981	4.58
7500	826	3320	3.82	882	3642	4.19	933	3953	4.55	980	4254	4.89	1025	4549	5.23
8000	873	3879	4.46	926	4217	4.85	975	4542	5.22	1021	4860	5.59	1065	5169	5.95
8500	921	4495	5.17	972	4847	5.57	1019	5189	5.97	1063	5521	6.35	1105	5846	6.72

AIRFLOW (Cfm)	AVAILABLE EXTERNAL STATIC PRESSURE (in. wg)														
	1.2			1.4			1.6			1.8			2.0		
	Rpm	Watts	Bhp	Rpm	Watts	Bhp	Rpm	Watts	Bhp	Rpm	Watts	Bhp	Rpm	Watts	Bhp
3500	818	1488	1.71	874	1661	1.91	927	1835	2.11	978	2008	2.31	1026	2182	2.51
4000	840	1760	2.02	893	1948	2.24	943	2136	2.46	992	2324	2.67	1039	2512	2.89
4500	865	2068	2.38	915	2270	2.61	964	2472	2.84	1011	2673	3.07	1056	2876	3.31
5000	893	2417	2.78	942	2632	3.03	988	2848	3.28	1033	3063	3.52	1076	3278	3.77
5500	925	2808	3.23	971	3037	3.49	1016	3266	3.76	1059	3494	4.02	1100	3721	4.28
6000	958	3243	3.73	1003	3486	4.01	1045	3728	4.29	1087	3970	4.57	1127	4210	4.84
6500	993	3725	4.28	1036	3982	4.58	1077	4238	4.87	1117	4492	5.17	1156	4745	5.46
7000	1029	4256	4.90	1071	4528	5.21	1111	4797	5.52	1150	5064	5.82	1187	5330	6.13
7500	1067	4838	5.56	1107	5124	5.89	1146	5407	6.22	1184	5688	6.54	1220	5967	6.86
8000	1106	5474	6.30	1145	5774	6.64	1182	6071	6.98	1219	6365	7.32	1254	6657	7.66
8500	1145	6165	7.09	1183	6479	7.45	1220	6790	7.81	1255	7098	8.16	1290	7403	8.51

**LEGEND**

**Bhp** — Brake Horsepower Input to Fan  
**Watts** — Input Watts to Motor

\*Motor drive ranges:  
 Low Range: Not Used  
 Mid-Low Range: 647-886 (208/230 and 460-v), 810-1072 (575-v)  
 Mid-High Range: 897-1139 (208/230 and 460-v), 873-1108 (575-v)  
 High Range: 1078-1274  
 All other rpms require field-supplied drive.

Refer to page 27 for general Fan Performance Data notes.

NOTE: Maximum continuous bhp is:  
 Low Range: Not Used  
 Mid-Low Range: 4.25 (208/230 and 460-v), 3.45 (575-v)  
 Mid-High Range: 5.75  
 High Range: 8.63

**Table 8 — Fan Performance — 48HJD024 Vertical Discharge Units\***

AIRFLOW (Cfm)	AVAILABLE EXTERNAL STATIC PRESSURE (in. wg)														
	0.2			0.4			0.6			0.8			1.0		
	Rpm	Watts	Bhp	Rpm	Watts	Bhp	Rpm	Watts	Bhp	Rpm	Watts	Bhp	Rpm	Watts	Bhp
5,000	590	1276	1.47	663	1516	1.74	727	1745	2.01	786	1968	2.26	840	2189	2.52
5,500	633	1579	1.82	703	1838	2.11	764	2084	2.40	820	2324	2.67	872	2560	2.94
6,000	677	1925	2.21	744	2203	2.53	803	2467	2.84	857	2723	3.13	907	2974	3.42
6,500	722	2317	2.67	786	2614	3.01	842	2896	3.33	894	3167	3.64	942	3434	3.95
7,000	767	2758	3.17	828	3073	3.53	883	3371	3.88	933	3660	4.21	979	3942	4.53
7,500	813	3250	3.74	871	3582	4.12	924	3897	4.48	972	4202	4.83	1017	4500	5.18
8,000	859	3795	4.36	915	4143	4.77	966	4475	5.15	1012	4797	5.52	1056	5110	5.88
8,500	906	4394	5.05	959	4759	5.47	1008	5107	5.87	1053	5445	6.26	1096	5774	6.64
9,000	952	5051	5.81	1004	5432	6.25	1051	5797	6.67	1095	6150	7.07	1136	6494	7.47
9,500	999	5767	6.63	1049	6163	7.09	1094	6544	7.53	1137	6913	7.95	1177	7272	8.36
10,000	1047	6544	7.53	1094	6956	8.00	1138	7352	8.46	1180	7736	8.90	1219	8111	9.33

AIRFLOW (Cfm)	AVAILABLE EXTERNAL STATIC PRESSURE (in. wg)														
	1.2			1.4			1.6			1.8			2.0		
	Rpm	Watts	Bhp	Rpm	Watts	Bhp	Rpm	Watts	Bhp	Rpm	Watts	Bhp	Rpm	Watts	Bhp
5,000	891	2408	2.77	940	2625	3.02	987	2843	3.27	1032	3060	3.52	1076	3277	3.77
5,500	921	2792	3.21	968	3024	3.48	1014	3255	3.74	1057	3485	4.01	1099	3716	4.27
6,000	954	3221	3.70	999	3467	3.99	1042	3711	4.27	1084	3955	4.55	1125	4198	4.83
6,500	988	3696	4.25	1032	3956	4.55	1073	4214	4.85	1114	4470	5.14	1153	4726	5.44
7,000	1024	4219	4.85	1066	4493	5.17	1106	4764	5.48	1145	5034	5.79	1183	5303	6.10
7,500	1060	4792	5.51	1101	5080	5.84	1140	5365	6.17	1178	5649	6.50	1215	5930	6.82
8,000	1098	5417	6.23	1138	5719	6.58	1176	6018	6.92	1213	6315	7.26	1249	6610	7.60
8,500	1137	6096	7.01	1175	6413	7.38	1212	6726	7.74	1248	7036	8.09	1283	7344	8.45
9,000	1176	6831	7.86	1214	7163	8.24	1250	7490	8.61	1285	7814	8.99	1319	8135	9.36
9,500	1216	7624	8.77	1253	7970	9.17	1288	8312	9.56	1322	8649	9.95	1355	8984	10.33
10,000	1256	8478	9.75	1292	8838	10.16	1327	9193	10.57	1360	9545	10.98	1393	9893	11.38

**LEGEND**

**Bhp** — Brake Horsepower Input to Fan  
**Watts** — Input Watts to Motor

\*Motor drive ranges:  
 Low Range: 685-939 (208/230 and 460-v), 751-954 (575-v)  
 Mid-Low Range: 949-1206  
 Mid-High Range: 941-1176  
 High Range: 1014-1297  
 All other rpms require field-supplied drive.

Refer to page 27 for general Fan Performance Data notes.

NOTE: Maximum continuous bhp is:  
 Low Range: 4.25 (208/230 and 460-v), 5.75 (575-v)  
 Mid-Low Range: 5.75  
 Mid-High Range: 8.63  
 High Range: 11.50

**Table 9 — Fan Performance — 48HJE024 Vertical Discharge Units\***

AIRFLOW (Cfm)	AVAILABLE EXTERNAL STATIC PRESSURE (in. wg)														
	0.2			0.4			0.6			0.8			1.0		
	Rpm	Watts	Bhp	Rpm	Watts	Bhp	Rpm	Watts	Bhp	Rpm	Watts	Bhp	Rpm	Watts	Bhp
5,000	607	1329	1.53	677	1565	1.80	740	1791	2.06	797	2013	2.31	850	2231	2.57
5,500	652	1648	1.90	719	1902	2.19	779	2145	2.47	833	2382	2.74	884	2616	3.01
6,000	699	2013	2.32	763	2285	2.63	819	2545	2.93	872	2798	3.22	921	3046	3.50
6,500	746	2428	2.79	807	2716	3.12	861	2993	3.44	911	3262	3.75	958	3525	4.05
7,000	794	2895	3.33	851	3198	3.68	904	3491	4.02	952	3776	4.34	998	4055	4.66
7,500	842	3415	3.93	897	3735	4.30	947	4043	4.65	994	4343	5.00	1038	4637	5.33
8,000	891	3992	4.59	943	4327	4.98	991	4650	5.35	1036	4966	5.71	1079	5274	6.07
8,500	940	4628	5.32	990	4977	5.72	1036	5316	6.11	1080	5646	6.49	1121	5970	6.87
9,000	990	5325	6.12	1037	5688	6.54	1082	6042	6.95	1124	6386	7.35	1163	6724	7.73
9,500	1039	6085	7.00	1085	6462	7.43	1128	6829	7.85	1168	7188	8.27	1207	7541	8.67
10,000	1089	6911	7.95	1133	7301	8.40	1174	7682	8.83	1213	8055	9.26	1251	8421	9.69

AIRFLOW (Cfm)	AVAILABLE EXTERNAL STATIC PRESSURE (in. wg)														
	1.2			1.4			1.6			1.8			2.0		
	Rpm	Watts	Bhp	Rpm	Watts	Bhp	Rpm	Watts	Bhp	Rpm	Watts	Bhp	Rpm	Watts	Bhp
5,000	900	2448	2.82	949	2664	3.06	995	2879	3.31	1040	3095	3.56	1083	3310	3.81
5,500	933	2847	3.27	979	3077	3.54	1023	3305	3.80	1066	3534	4.06	1108	3762	4.33
6,000	967	3292	3.79	1011	3535	4.07	1054	3778	4.35	1095	4019	4.62	1135	4260	4.90
6,500	1003	3785	4.35	1046	4043	4.65	1087	4298	4.94	1127	4553	5.24	1165	4806	5.53
7,000	1041	4330	4.98	1082	4601	5.29	1122	4870	5.60	1160	5138	5.91	1197	5404	6.22
7,500	1079	4926	5.67	1119	5212	5.99	1158	5495	6.32	1195	5776	6.64	1231	6055	6.96
8,000	1119	5578	6.42	1158	5878	6.76	1195	6174	7.10	1231	6468	7.44	1267	6761	7.78
8,500	1160	6288	7.23	1198	6601	7.59	1234	6912	7.95	1269	7219	8.30	1303	7524	8.65
9,000	1202	7056	8.12	1238	7384	8.49	1273	7708	8.87	1308	8029	9.23	1341	8347	9.60
9,500	1244	7887	9.07	1279	8228	9.46	1314	8566	9.85	1347	8900	10.24	1379	9231	10.62
10,000	1287	8781	10.10	1321	9137	10.51	1355	9488	10.91	1387	9836	11.31	—	—	—

**LEGEND**

**Bhp** — Brake Horsepower Input to Fan  
**Watts** — Input Watts to Motor

\*Motor drive ranges:  
 Low Range: 685-939 (208/230 and 460-v), 751-954 (575-v)  
 Mid-Low Range: 949-1206  
 Mid-High Range: 941-1176  
 High Range: 1014-1297  
 All other rpms require field-supplied drive.

Refer to page 27 for general Fan Performance Data notes.

NOTE: Maximum continuous bhp is:  
 Low Range: 4.25 (208/230 and 460-v), 5.75 (575-v)  
 Mid-Low Range: 5.75  
 Mid-High Range: 8.63  
 High Range: 11.50

**Table 10 — Fan Performance — 48HJF024 Vertical Discharge Units\***

AIRFLOW (Cfm)	AVAILABLE EXTERNAL STATIC PRESSURE (in. wg)														
	0.2			0.4			0.6			0.8			1.0		
	Rpm	Watts	Bhp	Rpm	Watts	Bhp	Rpm	Watts	Bhp	Rpm	Watts	Bhp	Rpm	Watts	Bhp
5,000	607	1329	1.53	677	1565	1.80	740	1791	2.06	797	2013	2.31	850	2231	2.57
5,500	652	1648	1.90	719	1902	2.19	779	2145	2.47	833	2382	2.74	884	2616	3.01
6,000	699	2013	2.32	763	2285	2.63	819	2545	2.93	872	2798	3.22	921	3046	3.50
6,500	746	2428	2.79	807	2716	3.12	861	2993	3.44	911	3262	3.75	958	3525	4.05
7,000	794	2895	3.33	851	3198	3.68	904	3491	4.02	952	3776	4.34	998	4055	4.66
7,500	842	3415	3.93	897	3735	4.30	947	4043	4.65	994	4343	5.00	1038	4637	5.33
8,000	891	3992	4.59	943	4327	4.98	991	4650	5.35	1036	4966	5.71	1079	5274	6.07
8,500	940	4628	5.32	990	4977	5.72	1036	5316	6.11	1080	5646	6.49	1121	5970	6.87
9,000	990	5325	6.12	1037	5688	6.54	1082	6042	6.95	1124	6386	7.35	1163	6724	7.73
9,500	1039	6085	7.00	1085	6462	7.43	1128	6829	7.85	1168	7188	8.27	1207	7541	8.67
10,000	1089	6911	7.95	1133	7301	8.40	1174	7682	8.83	1213	8055	9.26	1251	8421	9.69

AIRFLOW (Cfm)	AVAILABLE EXTERNAL STATIC PRESSURE (in. wg)														
	1.2			1.4			1.6			1.8			2.0		
	Rpm	Watts	Bhp	Rpm	Watts	Bhp	Rpm	Watts	Bhp	Rpm	Watts	Bhp	Rpm	Watts	Bhp
5,000	900	2448	2.82	949	2664	3.06	995	2879	3.31	1040	3095	3.56	1083	3310	3.81
5,500	933	2847	3.27	979	3077	3.54	1023	3305	3.80	1066	3534	4.06	1108	3762	4.33
6,000	967	3292	3.79	1011	3535	4.07	1054	3778	4.35	1095	4019	4.62	1135	4260	4.90
6,500	1003	3785	4.35	1046	4043	4.65	1087	4298	4.94	1127	4553	5.24	1165	4806	5.53
7,000	1041	4330	4.98	1082	4601	5.29	1122	4870	5.60	1160	5138	5.91	1197	5404	6.22
7,500	1079	4926	5.67	1119	5212	5.99	1158	5495	6.32	1195	5776	6.64	1231	6055	6.96
8,000	1119	5578	6.42	1158	5878	6.76	1195	6174	7.10	1231	6468	7.44	1267	6761	7.78
8,500	1160	6288	7.23	1198	6601	7.59	1234	6912	7.95	1269	7219	8.30	1303	7524	8.65
9,000	1202	7056	8.12	1238	7384	8.49	1273	7708	8.87	1308	8029	9.23	1341	8347	9.60
9,500	1244	7887	9.07	1279	8228	9.46	1314	8566	9.85	1347	8900	10.24	1379	9231	10.62
10,000	1287	8781	10.10	1321	9137	10.51	1355	9488	10.91	1387	9836	11.31	—	—	—

**LEGEND**

**Bhp** — Brake Horsepower Input to Fan  
**Watts** — Input Watts to Motor

\*Motor drive ranges:  
 Low Range: 685-939 (208/230 and 460-v), 751-954 (575-v)  
 Mid-Low Range: 949-1206  
 Mid-High Range: 941-1176  
 High Range: 1014-1297  
 All other rpms require field-supplied drive.

Refer to page 27 for general Fan Performance Data notes.

NOTE: Maximum continuous bhp is:  
 Low Range: 4.25 (208/230 and 460-v), 5.75 (575-v)  
 Mid-Low Range: 5.75  
 Mid-High Range: 8.63  
 High Range: 11.50



Table 11 — Fan Performance — 48HJD028 Vertical Discharge Units\*

AIRFLOW (Cfm)	AVAILABLE EXTERNAL STATIC PRESSURE (in. wg)														
	0.2			0.4			0.6			0.8			1.0		
	Rpm	Watts	Bhp	Rpm	Watts	Bhp	Rpm	Watts	Bhp	Rpm	Watts	Bhp	Rpm	Watts	Bhp
6,500	750	2,468	2.84	806	2,767	3.18	854	3,031	3.49	898	3,298	3.79	943	3,584	4.12
7,000	797	2,942	3.38	853	3,276	3.77	899	3,557	4.09	941	3,832	4.41	982	4,118	4.74
7,500	845	3,468	3.99	900	3,840	4.42	945	4,142	4.76	985	4,430	5.09	1024	4,721	5.43
8,000	892	4,045	4.65	948	4,462	5.13	991	4,789	5.51	1030	5,092	5.86	1067	5,391	6.20
8,500	939	4,677	5.38	995	5,141	5.91	1038	5,497	6.32	1076	5,818	6.69	1112	6,129	7.05
9,000	986	5,364	6.17	1042	5,882	6.76	1085	6,269	7.21	1122	6,611	7.60	1157	6,936	7.98
9,500	1033	6,108	7.03	1090	6,684	7.69	1132	7,105	8.17	1169	7,470	8.59	1203	7,813	8.99
10,000	1079	6,911	7.95	1137	7,550	8.68	1180	8,007	9.21	1216	8,399	9.66	1249	8,761	10.08
10,500	1126	7,773	8.94	1184	8,480	9.75	1227	8,978	10.33	1263	9,399	10.81	1296	9,782	11.25
11,000	1172	8,696	10.00	1232	9,475	10.90	1274	10,017	11.52	1310	10,468	12.04	1342	10,876	12.51
11,500	1219	9,681	11.13	1279	10,539	12.12	1322	11,127	12.80	1357	11,611	13.35	—	—	—
12,000	1265	10,732	12.34	1326	11,669	13.42	—	—	—	—	—	—	—	—	—
12,500	1311	11,848	13.63	—	—	—	—	—	—	—	—	—	—	—	—

AIRFLOW (Cfm)	AVAILABLE EXTERNAL STATIC PRESSURE (in. wg)														
	1.2			1.4			1.6			1.8			2.0		
	Rpm	Watts	Bhp	Rpm	Watts	Bhp	Rpm	Watts	Bhp	Rpm	Watts	Bhp	Rpm	Watts	Bhp
6,500	988	3,900	4.49	1035	4,250	4.89	1082	4,634	5.33	1130	5,053	5.81	1177	5,499	6.32
7,000	1024	4,426	5.09	1066	4,760	5.48	1109	5,126	5.90	1153	5,524	6.35	1197	5,953	6.85
7,500	1063	5,026	5.78	1101	5,351	6.15	1141	5,702	6.56	1181	6,081	6.99	1222	6,490	7.46
8,000	1104	5,698	6.55	1140	6,020	6.92	1176	6,361	7.32	1213	6,727	7.74	1251	7,118	8.19
8,500	1146	6,443	7.41	1180	6,765	7.78	1214	7,103	8.17	1249	7,459	8.58	1283	7,837	9.01
9,000	1190	7,259	8.35	1222	7,586	8.73	1255	7,925	9.11	1287	8,276	9.52	1319	8,645	9.94
9,500	1235	8,148	9.37	1266	8,483	9.76	1296	8,824	10.15	1327	9,176	10.55	1357	9,541	10.97
10,000	1280	9,111	10.48	1310	9,456	10.88	1340	9,804	11.28	1369	10,158	11.68	1398	10,522	12.10
10,500	1326	10,147	11.67	1355	10,505	12.08	1384	10,862	12.49	—	—	—	—	—	—
11,000	1372	11,259	12.95	—	—	—	—	—	—	—	—	—	—	—	—
11,500	—	—	—	—	—	—	—	—	—	—	—	—	—	—	—
12,000	—	—	—	—	—	—	—	—	—	—	—	—	—	—	—
12,500	—	—	—	—	—	—	—	—	—	—	—	—	—	—	—

LEGEND

**Bhp** — Brake Horsepower Input to Fan  
**Watts** — Input Watts to Motor

\*Motor drive ranges:  
 Low Range: 687-873  
 Mid-Low Range: 805-1007  
 Mid-High Range: 941-1176  
 High Range: 1014-1297  
 All other rpms require field-supplied drive.

Refer to page 27 for general Fan Performance Data notes.

NOTE: Maximum continuous bhp is:  
 Low Range: 5.75  
 Mid-Low Range: 5.75  
 Mid-High Range: 8.63  
 High Range: 11.50

Table 12 — Fan Performance — 48HJE028 Vertical Discharge Units\*

AIRFLOW (Cfm)	AVAILABLE EXTERNAL STATIC PRESSURE (in. wg)														
	0.2			0.4			0.6			0.8			1.0		
	Rpm	Watts	Bhp	Rpm	Watts	Bhp	Rpm	Watts	Bhp	Rpm	Watts	Bhp	Rpm	Watts	Bhp
6,500	775	2,600	2.99	825	2,872	3.30	871	3,130	3.60	915	3,400	3.91	959	3,692	4.25
7,000	826	3,115	3.58	875	3,408	3.92	918	3,679	4.23	959	3,954	4.55	1000	4,245	4.88
7,500	878	3,690	4.24	925	4,006	4.61	966	4,292	4.94	1005	4,575	5.26	1043	4,868	5.60
8,000	929	4,326	4.98	975	4,667	5.37	1015	4,970	5.72	1052	5,265	6.06	1088	5,564	6.40
8,500	981	5,029	5.78	1026	5,395	6.20	1064	5,717	6.58	1100	6,025	6.93	1134	6,332	7.28
9,000	1033	5,799	6.67	1076	6,191	7.12	1114	6,533	7.51	1148	6,856	7.89	1181	7,173	8.25
9,500	1085	6,640	7.64	1128	7,058	8.12	1164	7,421	8.54	1198	7,761	8.93	1229	8,091	9.31
10,000	1137	7,553	8.69	1179	8,000	9.20	1214	8,385	9.64	1247	8,741	10.05	1278	9,086	10.45
10,500	1190	8,542	9.82	1230	9,016	10.37	1265	9,424	10.84	1297	9,799	11.27	1327	10,158	11.68
11,000	1242	9,609	11.05	1282	10,111	11.63	1316	10,542	12.12	1347	10,937	12.58	1376	11,311	13.01
11,500	1294	10,756	12.37	1333	11,287	12.98	1367	11,741	13.50	—	—	—	—	—	—
12,000	1347	11,985	13.78	—	—	—	—	—	—	—	—	—	—	—	—
12,500	—	—	—	—	—	—	—	—	—	—	—	—	—	—	—

AIRFLOW (Cfm)	AVAILABLE EXTERNAL STATIC PRESSURE (in. wg)														
	1.2			1.4			1.6			1.8			2.0		
	Rpm	Watts	Bhp	Rpm	Watts	Bhp	Rpm	Watts	Bhp	Rpm	Watts	Bhp	Rpm	Watts	Bhp
6,500	1004	4,016	4.62	1050	4,374	5.03	1098	4,769	5.48	1145	5,195	5.97	1192	5,646	6.49
7,000	1041	4,559	5.24	1083	4,902	5.64	1126	5,277	6.07	1170	5,685	6.54	1214	6,122	7.04
7,500	1081	5,179	5.96	1120	5,512	6.34	1159	5,872	6.75	1199	6,261	7.20	1240	6,680	7.68
8,000	1124	5,875	6.76	1160	6,203	7.13	1196	6,553	7.54	1233	6,928	7.97	1270	7,329	8.43
8,500	1168	6,647	7.64	1202	6,974	8.02	1235	7,318	8.42	1269	7,684	8.84	1304	8,071	9.28
9,000	1214	7,495	8.62	1245	7,825	9.00	1277	8,168	9.39	1309	8,527	9.81	1341	8,905	10.24
9,500	1260	8,421	9.69	1290	8,756	10.07	1320	9,100	10.47	1351	9,457	10.88	1381	9,830	11.31
10,000	1308	9,425	10.84	1337	9,768	11.23	1365	10,116	11.63	1394	10,474	12.05	—	—	—
10,500	1356	10,510	12.09	1384	10,862	12.49	—	—	—	—	—	—	—	—	—
11,000	—	—	—	—	—	—	—	—	—	—	—	—	—	—	—
11,500	—	—	—	—	—	—	—	—	—	—	—	—	—	—	—
12,000	—	—	—	—	—	—	—	—	—	—	—	—	—	—	—
12,500	—	—	—	—	—	—	—	—	—	—	—	—	—	—	—

LEGEND

**Bhp** — Brake Horsepower Input to Fan  
**Watts** — Input Watts to Motor

\*Motor drive ranges:  
 Low Range: 687-873  
 Mid-Low Range: 805-1007  
 Mid-High Range: 941-1176  
 High Range: 1014-1297  
 All other rpms require field-supplied drive.

Refer to page 27 for general Fan Performance Data notes.

NOTE: Maximum continuous bhp is:  
 Low Range: 5.75  
 Mid-Low Range: 5.75  
 Mid-High Range: 8.63  
 High Range: 11.50

**Table 13 — Fan Performance — 48HJF028 Vertical Discharge Units\***

AIRFLOW (Cfm)	AVAILABLE EXTERNAL STATIC PRESSURE (in. wg)														
	0.2			0.4			0.6			0.8			1.0		
	Rpm	Watts	Bhp	Rpm	Watts	Bhp	Rpm	Watts	Bhp	Rpm	Watts	Bhp	Rpm	Watts	Bhp
6,500	775	2,600	2.99	825	2,872	3.30	871	3,130	3.60	915	3,400	3.91	959	3,692	4.25
7,000	826	3,115	3.58	875	3,408	3.92	918	3,679	4.23	959	3,954	4.55	1000	4,245	4.88
7,500	878	3,690	4.24	925	4,006	4.61	966	4,292	4.94	1005	4,575	5.26	1043	4,868	5.60
8,000	929	4,326	4.98	975	4,667	5.37	1015	4,970	5.72	1052	5,265	6.06	1088	5,564	6.40
8,500	981	5,029	5.78	1026	5,395	6.20	1064	5,717	6.58	1100	6,025	6.93	1134	6,332	7.28
9,000	1033	5,799	6.67	1076	6,191	7.12	1114	6,533	7.51	1148	6,856	7.89	1181	7,173	8.25
9,500	1085	6,640	7.64	1128	7,058	8.12	1164	7,421	8.54	1198	7,761	8.93	1229	8,091	9.31
10,000	1137	7,553	8.69	1179	8,000	9.20	1214	8,385	9.64	1247	8,741	10.05	1278	9,086	10.45
10,500	1190	8,542	9.82	1230	9,016	10.37	1265	9,424	10.84	1297	9,799	11.27	1327	10,158	11.68
11,000	1242	9,609	11.05	1282	10,111	11.63	1316	10,542	12.12	1347	10,937	12.58	1376	11,311	13.01
11,500	1294	10,756	12.37	1333	11,287	12.98	1367	11,741	13.50	—	—	—	—	—	—
12,000	1347	11,985	13.78	—	—	—	—	—	—	—	—	—	—	—	—
12,500	—	—	—	—	—	—	—	—	—	—	—	—	—	—	—

AIRFLOW (Cfm)	AVAILABLE EXTERNAL STATIC PRESSURE (in. wg)														
	1.2			1.4			1.6			1.8			2.0		
	Rpm	Watts	Bhp	Rpm	Watts	Bhp	Rpm	Watts	Bhp	Rpm	Watts	Bhp	Rpm	Watts	Bhp
6,500	1004	4,016	4.62	1050	4,374	5.03	1098	4,769	5.48	1145	5,195	5.97	1192	5,646	6.49
7,000	1041	4,559	5.24	1083	4,902	5.64	1126	5,277	6.07	1170	5,685	6.54	1214	6,122	7.04
7,500	1081	5,179	5.96	1120	5,512	6.34	1159	5,872	6.75	1199	6,261	7.20	1240	6,680	7.68
8,000	1124	5,875	6.76	1160	6,203	7.13	1196	6,553	7.54	1233	6,928	7.97	1270	7,329	8.43
8,500	1168	6,647	7.64	1202	6,974	8.02	1235	7,318	8.42	1269	7,684	8.84	1304	8,071	9.28
9,000	1214	7,495	8.62	1245	7,825	9.00	1277	8,168	9.39	1309	8,527	9.81	1341	8,905	10.24
9,500	1260	8,421	9.69	1290	8,756	10.07	1320	9,100	10.47	1351	9,457	10.88	1381	9,830	11.31
10,000	1308	9,425	10.84	1337	9,768	11.23	1365	10,116	11.63	1394	10,474	12.05	—	—	—
10,500	1356	10,510	12.09	1384	10,862	12.49	—	—	—	—	—	—	—	—	—
11,000	—	—	—	—	—	—	—	—	—	—	—	—	—	—	—
11,500	—	—	—	—	—	—	—	—	—	—	—	—	—	—	—
12,000	—	—	—	—	—	—	—	—	—	—	—	—	—	—	—
12,500	—	—	—	—	—	—	—	—	—	—	—	—	—	—	—

**LEGEND**

**Bhp** — Brake Horsepower Input to Fan  
**Watts** — Input Watts to Motor

\*Motor drive ranges:  
 Low Range: 687-873  
 Mid-Low Range: 805-1007  
 Mid-High Range: 941-1176  
 High Range: 1014-1297

All other rpms require field-supplied drive.

Refer to this page for general Fan Performance Data notes.

NOTE: Maximum continuous bhp is:  
 Low Range: 5.75  
 Mid-Low Range: 5.75  
 Mid-High Range: 8.63  
 High Range: 11.50

**GENERAL NOTES FOR TABLES 5-22**

- Static pressure losses (i.e., EconoMi\$er IV) from Table 26 must be added to external static pressure before entering Fan Performance table.
- Interpolation is permissible. Do not extrapolate.
- Fan performance is based on wet coils, clean filters, and casing losses. See Table 26 on page 39.
- Extensive motor and drive testing on these units ensures that the full horsepower and watts range of the motor can be utilized with confidence. Using the fan motors up to the watts or bhp rating shown will not result in nuisance tripping or premature motor failure. Unit warranty will not be affected.
- Use of a field-supplied motor may affect wire size. Contact your Carrier representative for details.

**Table 14 — Fan Performance — 48HJD020 Horizontal Discharge Units\***

AIRFLOW (Cfm)	EXTERNAL STATIC PRESSURE (in. wg)														
	0.2			0.4			0.6			0.8			1.0		
	Rpm	Bhp	Watts	Rpm	Bhp	Watts	Rpm	Bhp	Watts	Rpm	Bhp	Watts	Rpm	Bhp	Watts
3,500	635	1064	1.22	709	1278	1.47	776	1492	1.72	838	1708	1.96	896	1924	2.21
4,000	707	1402	1.61	773	1627	1.87	835	1853	2.13	892	2080	2.39	947	2307	2.65
4,500	780	1802	2.07	840	2037	2.34	897	2273	2.61	950	2510	2.89	1001	2465	2.84
5,000	853	2264	2.60	909	2510	2.89	961	2756	3.17	1011	2710	3.12	1059	3015	3.47
5,500	928	2794	3.21	979	3049	3.51	1028	3012	3.46	1075	3333	3.83	1120	3661	4.21
6,000	1003	3047	3.50	1051	3376	3.88	1096	3714	4.27	1140	4059	4.67	1182	4411	5.07
6,500	1079	3812	4.38	1123	4166	4.79	1166	4529	5.21	1207	4898	5.63	1247	5274	6.07
7,000	1155	4697	5.40	1196	5078	5.84	1236	5465	6.29	1275	5859	6.74	1313	6260	7.20
7,500	1231	5714	6.57	1270	6120	7.04	1308	6533	7.51	1345	6952	8.00	1381	7378	8.49
8,000	1308	6871	7.90	1344	7303	8.40	1380	7741	8.90	—	—	—	—	—	—
8,500	1385	8177	9.40	—	—	—	—	—	—	—	—	—	—	—	—
9,000	—	—	—	—	—	—	—	—	—	—	—	—	—	—	—
9,500	—	—	—	—	—	—	—	—	—	—	—	—	—	—	—
10,000	—	—	—	—	—	—	—	—	—	—	—	—	—	—	—

AIRFLOW (Cfm)	EXTERNAL STATIC PRESSURE (in. wg)														
	1.2			1.4			1.6			1.8			2.0		
	Rpm	Bhp	Watts	Rpm	Bhp	Watts	Rpm	Bhp	Watts	Rpm	Bhp	Watts	Rpm	Bhp	Watts
3,500	951	2143	2.46	1003	2120	2.44	1052	2387	2.75	1100	2662	3.06	1146	2944	3.39
4,000	998	2535	2.92	1048	2548	2.93	1095	2835	3.26	1141	3129	3.60	1184	3432	3.95
4,500	1050	2756	3.17	1097	3055	3.51	1142	3363	3.87	1185	3678	4.23	1227	4001	4.60
5,000	1105	3329	3.83	1150	3651	4.20	1192	3979	4.58	1234	4315	4.96	1274	4658	5.36
5,500	1163	3997	4.60	1205	4342	4.99	1246	4692	5.40	1286	5051	5.81	1324	5415	6.23
6,000	1224	4771	5.49	1263	5138	5.91	1302	5511	6.34	1340	5892	6.78	1377	6278	7.22
6,500	1286	5658	6.51	1324	6048	6.96	1361	6445	7.41	1397	6847	7.87	—	—	—
7,000	1350	6668	7.67	1386	7081	8.14	—	—	—	—	—	—	—	—	—
7,500	—	—	—	—	—	—	—	—	—	—	—	—	—	—	—
8,000	—	—	—	—	—	—	—	—	—	—	—	—	—	—	—
8,500	—	—	—	—	—	—	—	—	—	—	—	—	—	—	—
9,000	—	—	—	—	—	—	—	—	—	—	—	—	—	—	—
9,500	—	—	—	—	—	—	—	—	—	—	—	—	—	—	—
10,000	—	—	—	—	—	—	—	—	—	—	—	—	—	—	—

**LEGEND**

**Bhp** — Brake Horsepower Input to Fan  
**Watts** — Input Watts to Motor

\*Motor drive ranges:  
 Low Range: Not Used  
 Mid-Low Range: 896-1227 (208/230 and 460-v), 863-1141 (575-v)  
 Mid-High Range: 1113-1414 (208/230 and 460-v), 1042-1285 (575-v)  
 High Range: 1096-1339  
 All other rpms require field-supplied drive.

Refer to page 27 for general Fan Performance Data notes.

NOTE: Maximum continuous bhp is:  
 Low Range: Not Used  
 Mid-Low Range: 4.25 (208/230 and 460-v), 3.45 (575-v)  
 Mid-High Range: 5.75  
 High Range: 8.63

**Table 15 — Fan Performance — 48HJE020 Horizontal Discharge Units\***

AIRFLOW (Cfm)	EXTERNAL STATIC PRESSURE (in. wg)														
	0.2			0.4			0.6			0.8			1.0		
	Rpm	Bhp	Watts	Rpm	Bhp	Watts	Rpm	Bhp	Watts	Rpm	Bhp	Watts	Rpm	Bhp	Watts
3,500	645	1105	1.27	720	1329	1.53	788	1549	1.78	851	1767	2.03	910	1982	2.28
4,000	718	1454	1.67	785	1692	1.95	848	1926	2.22	906	2158	2.48	962	2388	2.75
4,500	792	1866	2.15	853	2117	2.43	911	2364	2.72	965	2609	3.00	1017	2583	2.97
5,000	867	2343	2.69	923	2605	3.00	977	2865	3.30	1027	2845	3.27	1076	3163	3.64
5,500	943	2889	3.32	995	3162	3.64	1044	3158	3.63	1092	3497	4.02	1138	3843	4.42
6,000	1019	3177	3.65	1067	3532	4.06	1113	3892	4.48	1158	4259	4.90	1201	4631	5.33
6,500	1096	3973	4.57	1141	4354	5.01	1184	4742	5.45	1226	5136	5.91	1267	5535	6.37
7,000	1173	4894	5.63	1215	5304	6.10	1256	5719	6.58	1295	6140	7.06	1334	6567	7.55
7,500	1250	5952	6.85	1290	6389	7.35	1328	6832	7.86	1366	7281	8.37	—	—	—
8,000	1328	7153	8.23	1365	7620	8.76	—	—	—	—	—	—	—	—	—
8,500	—	—	—	—	—	—	—	—	—	—	—	—	—	—	—
9,000	—	—	—	—	—	—	—	—	—	—	—	—	—	—	—
9,500	—	—	—	—	—	—	—	—	—	—	—	—	—	—	—
10,000	—	—	—	—	—	—	—	—	—	—	—	—	—	—	—

AIRFLOW (Cfm)	EXTERNAL STATIC PRESSURE (in. wg)														
	1.2			1.4			1.6			1.8			2.0		
	Rpm	Bhp	Watts	Rpm	Bhp	Watts	Rpm	Bhp	Watts	Rpm	Bhp	Watts	Rpm	Bhp	Watts
3,500	965	2195	2.53	1018	2181	2.51	1068	2442	2.81	1116	2708	3.11	1162	2979	3.43
4,000	1014	2364	2.72	1064	2644	3.04	1112	2930	3.37	1158	3221	3.70	1202	3517	4.05
4,500	1067	2882	3.31	1114	3187	3.67	1160	3498	4.02	1204	3814	4.39	1246	4135	4.76
5,000	1123	3489	4.01	1168	3820	4.39	1211	4156	4.78	1253	4497	5.17	1294	4844	5.57
5,500	1182	4194	4.82	1224	4551	5.23	1266	4913	5.65	1306	5280	6.07	1345	5652	6.50
6,000	1243	5008	5.76	1283	5391	6.20	1323	5779	6.65	1361	6172	7.10	1398	6569	7.56
6,500	1306	5939	6.83	1345	6349	7.30	1382	6763	7.78	—	—	—	—	—	—
7,000	1371	6997	8.05	—	—	—	—	—	—	—	—	—	—	—	—
7,500	—	—	—	—	—	—	—	—	—	—	—	—	—	—	—
8,000	—	—	—	—	—	—	—	—	—	—	—	—	—	—	—
8,500	—	—	—	—	—	—	—	—	—	—	—	—	—	—	—
9,000	—	—	—	—	—	—	—	—	—	—	—	—	—	—	—
9,500	—	—	—	—	—	—	—	—	—	—	—	—	—	—	—
10,000	—	—	—	—	—	—	—	—	—	—	—	—	—	—	—

**LEGEND**

**Bhp** — Brake Horsepower Input to Fan  
**Watts** — Input Watts to Motor

\*Motor drive ranges:  
 Low Range: Not Used  
 Mid-Low Range: 896-1227 (208/230 and 460-v), 863-1141 (575-v)  
 Mid-High Range: 1113-1414 (208/230 and 460-v), 1042-1285 (575-v)  
 High Range: 1096-1339  
 All other rpms require field-supplied drive.

Refer to page 27 for general Fan Performance Data notes.

NOTE: Maximum continuous bhp is:  
 Low Range: Not Used  
 Mid-Low Range: 4.25 (208/230 and 460-v), 3.45 (575-v)  
 Mid-High Range: 5.75  
 High Range: 8.63

**Table 16 — Fan Performance — 48HJF020 Horizontal Discharge Units\***

AIRFLOW (Cfm)	EXTERNAL STATIC PRESSURE (in. wg)														
	0.2			0.4			0.6			0.8			1.0		
	Rpm	Bhp	Watts	Rpm	Bhp	Watts	Rpm	Bhp	Watts	Rpm	Bhp	Watts	Rpm	Bhp	Watts
3,500	645	1105	1.27	720	1329	1.53	788	1549	1.78	851	1767	2.03	910	1982	2.28
4,000	718	1454	1.67	785	1692	1.95	848	1926	2.22	906	2158	2.48	962	2388	2.75
4,500	792	1866	2.15	853	2117	2.43	911	2364	2.72	965	2609	3.00	1017	2583	2.97
5,000	867	2343	2.69	923	2605	3.00	977	2865	3.30	1027	2845	3.27	1076	3163	3.64
5,500	943	2889	3.32	995	3162	3.64	1044	3158	3.63	1092	3497	4.02	1138	3843	4.42
6,000	1019	3177	3.65	1067	3532	4.06	1113	3892	4.48	1158	4259	4.90	1201	4631	5.33
6,500	1096	3973	4.57	1141	4354	5.01	1184	4742	5.45	1226	5136	5.91	1267	5535	6.37
7,000	1173	4894	5.63	1215	5304	6.10	1256	5719	6.58	1295	6140	7.06	1334	6567	7.55
7,500	1250	5952	6.85	1290	6389	7.35	1328	6832	7.86	1366	7281	8.37	—	—	—
8,000	1328	7153	8.23	1365	7620	8.76	—	—	—	—	—	—	—	—	—
8,500	—	—	—	—	—	—	—	—	—	—	—	—	—	—	—
9,000	—	—	—	—	—	—	—	—	—	—	—	—	—	—	—
9,500	—	—	—	—	—	—	—	—	—	—	—	—	—	—	—
10,000	—	—	—	—	—	—	—	—	—	—	—	—	—	—	—

AIRFLOW (Cfm)	EXTERNAL STATIC PRESSURE (in. wg)														
	1.2			1.4			1.6			1.8			2.0		
	Rpm	Bhp	Watts	Rpm	Bhp	Watts	Rpm	Bhp	Watts	Rpm	Bhp	Watts	Rpm	Bhp	Watts
3,500	965	2195	2.53	1018	2181	2.51	1068	2442	2.81	1116	2708	3.11	1162	2979	3.43
4,000	1014	2364	2.72	1064	2644	3.04	1112	2930	3.37	1158	3221	3.70	1202	3517	4.05
4,500	1067	2882	3.31	1114	3187	3.67	1160	3498	4.02	1204	3814	4.39	1246	4135	4.76
5,000	1123	3489	4.01	1168	3820	4.39	1211	4156	4.78	1253	4497	5.17	1294	4844	5.57
5,500	1182	4194	4.82	1224	4551	5.23	1266	4913	5.65	1306	5280	6.07	1345	5652	6.50
6,000	1243	5008	5.76	1283	5391	6.20	1323	5779	6.65	1361	6172	7.10	1398	6569	7.56
6,500	1306	5939	6.83	1345	6349	7.30	1382	6763	7.78	—	—	—	—	—	—
7,000	1371	6997	8.05	—	—	—	—	—	—	—	—	—	—	—	—
7,500	—	—	—	—	—	—	—	—	—	—	—	—	—	—	—
8,000	—	—	—	—	—	—	—	—	—	—	—	—	—	—	—
8,500	—	—	—	—	—	—	—	—	—	—	—	—	—	—	—
9,000	—	—	—	—	—	—	—	—	—	—	—	—	—	—	—
9,500	—	—	—	—	—	—	—	—	—	—	—	—	—	—	—
10,000	—	—	—	—	—	—	—	—	—	—	—	—	—	—	—

**LEGEND**

**Bhp** — Brake Horsepower Input to Fan  
**Watts** — Input Watts to Motor

\*Motor drive ranges:  
 Low Range: Not Used  
 Mid-Low Range: 896-1227 (208/230 and 460-v), 863-1141 (575-v)  
 Mid-High Range: 1113-1414 (208/230 and 460-v), 1042-1285 (575-v)  
 High Range: 1096-1339  
 All other rpms require field-supplied drive.

Refer to page 27 for general Fan Performance Data notes.

NOTE: Maximum continuous bhp is:  
 Low Range: Not Used  
 Mid-Low Range: 4.25 (208/230 and 460-v), 3.45 (575-v)  
 Mid-High Range: 5.75  
 High Range: 8.63

**Table 17 — Fan Performance — 48HJD024 Horizontal Discharge Units\***

AIRFLOW (Cfm)	EXTERNAL STATIC PRESSURE (in. wg)														
	0.2			0.4			0.6			0.8			1.0		
	Rpm	Bhp	Watts	Rpm	Bhp	Watts	Rpm	Bhp	Watts	Rpm	Bhp	Watts	Rpm	Bhp	Watts
3,500	642	1082	1.24	714	1296	1.49	781	1510	1.74	843	1726	1.98	901	1943	2.23
4,000	714	1426	1.64	780	1651	1.90	841	1877	2.16	898	2103	2.42	952	2330	2.68
4,500	787	1831	2.11	847	2067	2.38	904	2303	2.65	957	2540	2.92	1008	2501	2.88
5,000	862	2301	2.65	917	2547	2.93	969	2793	3.21	1019	2755	3.17	1066	3062	3.52
5,500	937	2838	3.26	988	3094	3.56	1036	3067	3.53	1083	3390	3.90	1127	3719	4.28
6,000	1013	3113	3.58	1060	3445	3.96	1105	3783	4.35	1149	4130	4.75	1191	4484	5.16
6,500	1089	3893	4.48	1133	4250	4.89	1175	4615	5.31	1216	4986	5.73	1256	5364	6.17
7,000	1166	4798	5.52	1207	5181	5.96	1247	5570	6.41	1285	5965	6.86	1323	6369	7.32
7,500	1243	5837	6.71	1282	6244	7.18	1319	6658	7.66	1355	7080	8.14	1391	7507	8.63
8,000	1320	7017	8.07	1356	7450	8.57	1392	7890	9.08	—	—	—	—	—	—
8,500	1398	8350	9.60	—	—	—	—	—	—	—	—	—	—	—	—
9,000	—	—	—	—	—	—	—	—	—	—	—	—	—	—	—
9,500	—	—	—	—	—	—	—	—	—	—	—	—	—	—	—
10,000	—	—	—	—	—	—	—	—	—	—	—	—	—	—	—

AIRFLOW (Cfm)	EXTERNAL STATIC PRESSURE (in. wg)														
	1.2			1.4			1.6			1.8			2.0		
	Rpm	Bhp	Watts	Rpm	Bhp	Watts	Rpm	Bhp	Watts	Rpm	Bhp	Watts	Rpm	Bhp	Watts
3,500	955	2160	2.48	1007	2142	2.46	1056	2409	2.77	1104	2684	3.09	1149	2968	3.41
4,000	1004	2299	2.64	1053	2578	2.96	1100	2865	3.29	1145	3160	3.63	1189	3463	3.98
4,500	1056	2793	3.21	1103	3093	3.56	1147	3402	3.91	1191	3718	4.28	1233	4041	4.65
5,000	1112	3376	3.88	1156	3699	4.25	1199	4029	4.63	1240	4366	5.02	1280	4710	5.42
5,500	1171	4057	4.67	1212	4402	5.06	1253	4754	5.47	1292	5114	5.88	1331	5480	6.30
6,000	1232	4845	5.57	1271	5213	6.00	1310	5588	6.43	1348	5970	6.87	1384	6358	7.31
6,500	1295	5749	6.61	1333	6141	7.06	1369	6538	7.52	—	—	—	—	—	—
7,000	1360	6778	7.80	1396	7193	8.27	—	—	—	—	—	—	—	—	—
7,500	—	—	—	—	—	—	—	—	—	—	—	—	—	—	—
8,000	—	—	—	—	—	—	—	—	—	—	—	—	—	—	—
8,500	—	—	—	—	—	—	—	—	—	—	—	—	—	—	—
9,000	—	—	—	—	—	—	—	—	—	—	—	—	—	—	—
9,500	—	—	—	—	—	—	—	—	—	—	—	—	—	—	—
10,000	—	—	—	—	—	—	—	—	—	—	—	—	—	—	—

**LEGEND**

**Bhp** — Brake Horsepower Input to Fan  
**Watts** — Input Watts to Motor

\*Motor drive ranges:  
 Low Range: Not Used  
 Mid-Low Range: 896-1227 (208/230 and 460-v), 873-1108 (575-v)  
 Mid-High Range: 1113-1414  
 High Range: 1096-1339  
 All other rpms require field-supplied drive.

Refer to page 27 for general Fan Performance Data notes.

NOTE: Maximum continuous bhp is:  
 Low Range: Not Used  
 Mid-Low Range: 4.25 (208/230 and 460-v), 5.75 (575-v)  
 Mid-High Range: 5.75  
 High Range: 8.63

**Table 18 — Fan Performance — 48HJE024 Horizontal Discharge Units\***

AIRFLOW (Cfm)	EXTERNAL STATIC PRESSURE (in. wg)														
	0.2			0.4			0.6			0.8			1.0		
	Rpm	Bhp	Watts	Rpm	Bhp	Watts	Rpm	Bhp	Watts	Rpm	Bhp	Watts	Rpm	Bhp	Watts
3,500	652	1123	1.29	726	1347	1.55	793	1567	1.80	856	1784	2.05	914	2000	2.30
4,000	725	1479	1.70	792	1716	1.97	854	1950	2.24	912	2182	2.51	967	2412	2.77
4,500	800	1897	2.18	861	2148	2.47	918	2395	2.75	972	2639	3.04	1024	2620	3.01
5,000	875	2383	2.74	931	2645	3.04	984	2904	3.34	1035	2892	3.33	1083	3212	3.69
5,500	952	2937	3.38	1003	2883	3.32	1053	3217	3.70	1100	3558	4.09	1145	3905	4.49
6,000	1029	3249	3.74	1077	3605	4.15	1123	3966	4.56	1167	4334	4.98	1210	4707	5.41
6,500	1106	4061	4.67	1151	4445	5.11	1194	4834	5.56	1236	5229	6.01	1276	5629	6.47
7,000	1184	5003	5.75	1226	5414	6.23	1266	5831	6.71	1306	6253	7.19	1344	6681	7.68
7,500	1262	6083	7.00	1302	6522	7.50	1340	6967	8.01	1377	7417	8.53	—	—	—
8,000	1341	7312	8.41	1378	7779	8.95	—	—	—	—	—	—	—	—	—
8,500	—	—	—	—	—	—	—	—	—	—	—	—	—	—	—
9,000	—	—	—	—	—	—	—	—	—	—	—	—	—	—	—
9,500	—	—	—	—	—	—	—	—	—	—	—	—	—	—	—
10,000	—	—	—	—	—	—	—	—	—	—	—	—	—	—	—

AIRFLOW (Cfm)	EXTERNAL STATIC PRESSURE (in. wg)														
	1.2			1.4			1.6			1.8			2.0		
	Rpm	Bhp	Watts	Rpm	Bhp	Watts	Rpm	Bhp	Watts	Rpm	Bhp	Watts	Rpm	Bhp	Watts
3,500	970	2213	2.55	1022	2203	2.53	1072	2464	2.83	1120	2730	3.14	1166	3002	3.45
4,000	1019	2393	2.75	1069	2673	3.07	1117	2959	3.40	1163	3251	3.74	1207	3548	4.08
4,500	1073	2920	3.36	1120	3226	3.71	1165	3537	4.07	1209	3854	4.43	1252	4176	4.80
5,000	1130	3537	4.07	1174	3870	4.45	1218	4207	4.84	1259	4549	5.23	1300	4896	5.63
5,500	1189	4257	4.90	1232	4614	5.31	1273	4977	5.72	1313	5345	6.15	1352	5719	6.58
6,000	1251	5086	5.85	1292	5469	6.29	1331	5859	6.74	1369	6253	7.19	—	—	—
6,500	1315	6035	6.94	1354	6446	7.41	1391	6861	7.89	—	—	—	—	—	—
7,000	1381	7114	8.18	—	—	—	—	—	—	—	—	—	—	—	—
7,500	—	—	—	—	—	—	—	—	—	—	—	—	—	—	—
8,000	—	—	—	—	—	—	—	—	—	—	—	—	—	—	—
8,500	—	—	—	—	—	—	—	—	—	—	—	—	—	—	—
9,000	—	—	—	—	—	—	—	—	—	—	—	—	—	—	—
9,500	—	—	—	—	—	—	—	—	—	—	—	—	—	—	—
10,000	—	—	—	—	—	—	—	—	—	—	—	—	—	—	—

**LEGEND**

**Bhp** — Brake Horsepower Input to Fan  
**Watts** — Input Watts to Motor

\*Motor drive ranges:  
 Low Range: Not Used  
 Mid-Low Range: 896-1227 (208/230 and 460-v), 873-1108 (575-v)  
 Mid-High Range: 1113-1414  
 High Range: 1096-1339  
 All other rpms require field-supplied drive.

Refer to page 27 for general Fan Performance Data notes.

NOTE: Maximum continuous bhp is:  
 Low Range: Not Used  
 Mid-Low Range: 4.25 (208/230 and 460-v), 5.75 (575-v)  
 Mid-High Range: 5.75  
 High Range: 8.63



**Table 19 — Fan Performance — 48HJF024 Horizontal Discharge Units\***

AIRFLOW (Cfm)	EXTERNAL STATIC PRESSURE (in. wg)														
	0.2			0.4			0.6			0.8			1.0		
	Rpm	Bhp	Watts	Rpm	Bhp	Watts	Rpm	Bhp	Watts	Rpm	Bhp	Watts	Rpm	Bhp	Watts
3,500	652	1123	1.29	726	1347	1.55	793	1567	1.80	856	1784	2.05	914	2000	2.30
4,000	725	1479	1.70	792	1716	1.97	854	1950	2.24	912	2182	2.51	967	2412	2.77
4,500	800	1897	2.18	861	2148	2.47	918	2395	2.75	972	2639	3.04	1024	2620	3.01
5,000	875	2383	2.74	931	2645	3.04	984	2904	3.34	1035	2892	3.33	1083	3212	3.69
5,500	952	2937	3.38	1003	2883	3.32	1053	3217	3.70	1100	3558	4.09	1145	3905	4.49
6,000	1029	3249	3.74	1077	3605	4.15	1123	3966	4.56	1167	4334	4.98	1210	4707	5.41
6,500	1106	4061	4.67	1151	4445	5.11	1194	4834	5.56	1236	5229	6.01	1276	5629	6.47
7,000	1184	5003	5.75	1226	5414	6.23	1266	5831	6.71	1306	6253	7.19	1344	6681	7.68
7,500	1262	6083	7.00	1302	6522	7.50	1340	6967	8.01	1377	7417	8.53	—	—	—
8,000	1341	7312	8.41	1378	7779	8.95	—	—	—	—	—	—	—	—	—
8,500	—	—	—	—	—	—	—	—	—	—	—	—	—	—	—
9,000	—	—	—	—	—	—	—	—	—	—	—	—	—	—	—
9,500	—	—	—	—	—	—	—	—	—	—	—	—	—	—	—
10,000	—	—	—	—	—	—	—	—	—	—	—	—	—	—	—

AIRFLOW (Cfm)	EXTERNAL STATIC PRESSURE (in. wg)														
	1.2			1.4			1.6			1.8			2.0		
	Rpm	Bhp	Watts	Rpm	Bhp	Watts	Rpm	Bhp	Watts	Rpm	Bhp	Watts	Rpm	Bhp	Watts
3,500	970	2213	2.55	1022	2203	2.53	1072	2464	2.83	1120	2730	3.14	1166	3002	3.45
4,000	1019	2393	2.75	1069	2673	3.07	1117	2959	3.40	1163	3251	3.74	1207	3548	4.08
4,500	1073	2920	3.36	1120	3226	3.71	1165	3537	4.07	1209	3854	4.43	1252	4176	4.80
5,000	1130	3537	4.07	1174	3870	4.45	1218	4207	4.84	1259	4549	5.23	1300	4896	5.63
5,500	1189	4257	4.90	1232	4614	5.31	1273	4977	5.72	1313	5345	6.15	1352	5719	6.58
6,000	1251	5086	5.85	1292	5469	6.29	1331	5859	6.74	1369	6253	7.19	—	—	—
6,500	1315	6035	6.94	1354	6446	7.41	1391	6861	7.89	—	—	—	—	—	—
7,000	1381	7114	8.18	—	—	—	—	—	—	—	—	—	—	—	—
7,500	—	—	—	—	—	—	—	—	—	—	—	—	—	—	—
8,000	—	—	—	—	—	—	—	—	—	—	—	—	—	—	—
8,500	—	—	—	—	—	—	—	—	—	—	—	—	—	—	—
9,000	—	—	—	—	—	—	—	—	—	—	—	—	—	—	—
9,500	—	—	—	—	—	—	—	—	—	—	—	—	—	—	—
10,000	—	—	—	—	—	—	—	—	—	—	—	—	—	—	—

**LEGEND**

**Bhp** — Brake Horsepower Input to Fan  
**Watts** — Input Watts to Motor

\*Motor drive ranges:  
 Low Range: Not Used  
 Mid-Low Range: 896-1227 (208/230 and 460-v), 873-1108 (575-v)  
 Mid-High Range: 1113-1414  
 High Range: 1096-1339  
 All other rpms require field-supplied drive.

Refer to page 27 for general Fan Performance Data notes.

NOTE: Maximum continuous bhp is:  
 Low Range: Not Used  
 Mid-Low Range: 4.25 (208/230 and 460-v), 5.75 (575-v)  
 Mid-High Range: 5.75  
 High Range: 8.63

**Table 20 — Fan Performance — 48HJD028 Horizontal Discharge Units\***

AIRFLOW (Cfm)	EXTERNAL STATIC PRESSURE (in. wg)														
	0.2			0.4			0.6			0.8			1.0		
	Rpm	Bhp	Watts	Rpm	Bhp	Watts	Rpm	Bhp	Watts	Rpm	Bhp	Watts	Rpm	Bhp	Watts
6,500	786	2,658	3.06	819	2,835	3.26	857	3,052	3.51	899	3,304	3.80	943	3,586	4.12
7,000	842	3,208	3.69	871	3,386	3.89	905	3,599	4.14	943	3,847	4.42	983	4,123	4.74
7,500	898	3,827	4.40	925	4,006	4.61	955	4,217	4.85	989	4,460	5.13	1026	4,733	5.44
8,000	955	4,518	5.20	979	4,699	5.40	1007	4,908	5.65	1037	5,148	5.92	1070	5,416	6.23
8,500	1012	5,284	6.08	1034	5,466	6.29	1059	5,675	6.53	1087	5,912	6.80	1117	6,176	7.10
9,000	1069	6,127	7.05	1090	6,312	7.26	1113	6,521	7.50	1138	6,757	7.77	1165	7,017	8.07
9,500	1127	7,050	8.11	1146	7,238	8.32	1167	7,448	8.57	1190	7,682	8.84	1215	7,940	9.13
10,000	1184	8,057	9.27	1202	8,247	9.49	1221	8,460	9.73	1243	8,693	10.00	1266	8,948	10.29
10,500	1242	9,149	10.52	1258	9,344	10.75	1276	9,557	10.99	1296	9,791	11.26	1318	10,046	11.55
11,000	1299	10,331	11.88	1315	10,529	12.11	1332	10,745	12.36	1350	10,979	12.63	1370	11,232	12.92
11,500	1357	11,604	13.35	1372	11,806	13.58	—	—	—	—	—	—	—	—	—
12,000	—	—	—	—	—	—	—	—	—	—	—	—	—	—	—
12,500	—	—	—	—	—	—	—	—	—	—	—	—	—	—	—

AIRFLOW (Cfm)	EXTERNAL STATIC PRESSURE (in. wg)														
	1.2			1.4			1.6			1.8			2.0		
	Rpm	Bhp	Watts	Rpm	Bhp	Watts	Rpm	Bhp	Watts	Rpm	Bhp	Watts	Rpm	Bhp	Watts
6,500	988	3,900	4.49	1035	4,248	4.89	1082	4,632	5.33	1129	5,050	5.81	1177	5,499	6.32
7,000	1024	4,428	5.09	1066	4,760	5.48	1109	5,124	5.89	1153	5,521	6.35	1197	5,950	6.84
7,500	1063	5,031	5.79	1102	5,354	6.16	1141	5,703	6.56	1181	6,081	6.99	1221	6,487	7.46
8,000	1105	5,709	6.57	1140	6,025	6.93	1176	6,364	7.32	1213	6,729	7.74	1250	7,116	8.18
8,500	1149	6,465	7.44	1181	6,777	7.79	1215	7,109	8.18	1249	7,463	8.58	1283	7,838	9.02
9,000	1194	7,302	8.40	1225	7,608	8.75	1256	7,935	9.13	1287	8,282	9.53	1319	8,649	9.95
9,500	1242	8,222	9.46	1270	8,524	9.80	1298	8,847	10.17	1328	9,189	10.57	1358	9,548	10.98
10,000	1290	9,227	10.61	1316	9,525	10.96	1343	9,845	11.32	1370	10,181	11.71	1399	10,536	12.12
10,500	1340	10,321	11.87	1364	10,617	12.21	1389	10,932	12.57	—	—	—	—	—	—
11,000	1391	11,505	13.23	—	—	—	—	—	—	—	—	—	—	—	—
11,500	—	—	—	—	—	—	—	—	—	—	—	—	—	—	—
12,000	—	—	—	—	—	—	—	—	—	—	—	—	—	—	—
12,500	—	—	—	—	—	—	—	—	—	—	—	—	—	—	—

**LEGEND**

**Bhp** — Brake Horsepower Input to Fan  
**Watts** — Input Watts to Motor

\*Motor drive ranges:  
 Low Range: 687-873  
 Mid-Low Range: 805-1007  
 Mid-High Range: 941-1176  
 High Range: 1014-1297  
 All other rpms require field-supplied drive.

Refer to page 27 for general Fan Performance Data notes.

NOTE: Maximum continuous bhp is:  
 Low Range: 5.75  
 Mid-Low Range: 5.75  
 Mid-High Range: 8.63  
 High Range: 11.50

**Table 21 — Fan Performance — 48HJE028 Horizontal Discharge Units\***

AIRFLOW (Cfm)	EXTERNAL STATIC PRESSURE (in. wg)														
	0.2			0.4			0.6			0.8			1.0		
	Rpm	Bhp	Watts	Rpm	Bhp	Watts	Rpm	Bhp	Watts	Rpm	Bhp	Watts	Rpm	Bhp	Watts
6,500	799	2,730	3.14	833	2,914	3.35	872	3,135	3.61	914	3,392	3.90	958	3,687	4.24
7,000	856	3,294	3.79	887	3,481	4.00	921	3,699	4.25	958	3,950	4.54	999	4,235	4.87
7,500	913	3,929	4.52	941	4,118	4.74	972	4,335	4.99	1006	4,582	5.27	1042	4,860	5.59
8,000	971	4,637	5.33	996	4,829	5.55	1024	5,046	5.80	1055	5,290	6.08	1088	5,562	6.40
8,500	1029	5,421	6.24	1052	5,617	6.46	1078	5,835	6.71	1106	6,077	6.99	1136	6,345	7.30
9,000	1087	6,285	7.23	1108	6,484	7.46	1132	6,703	7.71	1158	6,946	7.99	1185	7,211	8.29
9,500	1145	7,231	8.32	1165	7,433	8.55	1187	7,655	8.80	1211	7,898	9.08	1236	8,161	9.39
10,000	1203	8,262	9.50	1222	8,468	9.74	1243	8,693	10.00	1265	8,936	10.28	1288	9,199	10.58
10,500	1261	9,381	10.79	1279	9,592	11.03	1299	9,820	11.29	1319	10,065	11.58	1341	10,327	11.88
11,000	1320	10,592	12.18	1337	10,807	12.43	1355	11,038	12.70	1374	11,284	12.98	1394	11,547	13.28
11,500	1378	11,896	13.68	—	—	—	—	—	—	—	—	—	—	—	—
12,000	—	—	—	—	—	—	—	—	—	—	—	—	—	—	—
12,500	—	—	—	—	—	—	—	—	—	—	—	—	—	—	—

AIRFLOW (Cfm)	EXTERNAL STATIC PRESSURE (in. wg)														
	1.2			1.4			1.6			1.8			2.0		
	Rpm	Bhp	Watts	Rpm	Bhp	Watts	Rpm	Bhp	Watts	Rpm	Bhp	Watts	Rpm	Bhp	Watts
6,500	1005	4,020	4.62	1052	4,390	5.05	1100	4,791	5.51	1148	5,221	6.00	1195	5673	6.52
7,000	1041	4,555	5.24	1084	4,908	5.64	1128	5,294	6.09	1172	5,710	6.57	1217	6153	7.08
7,500	1080	5,168	5.94	1119	5,508	6.33	1160	5,878	6.76	1201	6,279	7.22	1242	6708	7.71
8,000	1122	5,862	6.74	1158	6,190	7.12	1195	6,548	7.53	1233	6,934	7.97	1272	7347	8.45
8,500	1167	6,638	7.63	1200	6,959	8.00	1234	7,305	8.40	1269	7,677	8.83	1304	8076	9.29
9,000	1214	7,499	8.63	1244	7,813	8.99	1275	8,149	9.37	1308	8,511	9.79	1340	8896	10.23
9,500	1262	8,447	9.72	1290	8,754	10.07	1319	9,084	10.45	1349	9,437	10.85	1379	9812	11.28
10,000	1312	9,482	10.91	1338	9,785	11.25	1365	10,110	11.63	1392	10,454	12.02	—	—	—
10,500	1363	10,608	12.20	1387	10,909	12.55	—	—	—	—	—	—	—	—	—
11,000	—	—	—	—	—	—	—	—	—	—	—	—	—	—	—
11,500	—	—	—	—	—	—	—	—	—	—	—	—	—	—	—
12,000	—	—	—	—	—	—	—	—	—	—	—	—	—	—	—
12,500	—	—	—	—	—	—	—	—	—	—	—	—	—	—	—

**LEGEND**

**Bhp** — Brake Horsepower Input to Fan  
**Watts** — Input Watts to Motor

\*Motor drive ranges:  
 Low Range: 687-873  
 Mid-Low Range: 805-1007  
 Mid-High Range: 941-1176  
 High Range: 1014-1297

All other rpms require field-supplied drive.

Refer to page 27 for general Fan Performance Data notes.

NOTE: Maximum continuous bhp is:  
 Low Range: 5.75  
 Mid-Low Range: 5.75  
 Mid-High Range: 8.63  
 High Range: 11.50

**Table 22 — Fan Performance — 48HJF028 Horizontal Discharge Units\***

AIRFLOW (Cfm)	EXTERNAL STATIC PRESSURE (in. wg)														
	0.2			0.4			0.6			0.8			1.0		
	Rpm	Bhp	Watts	Rpm	Bhp	Watts	Rpm	Bhp	Watts	Rpm	Bhp	Watts	Rpm	Bhp	Watts
6,500	799	2,730	3.14	833	2,914	3.35	872	3,135	3.61	914	3,392	3.90	958	3,687	4.24
7,000	856	3,294	3.79	887	3,481	4.00	921	3,699	4.25	958	3,950	4.54	999	4,235	4.87
7,500	913	3,929	4.52	941	4,118	4.74	972	4,335	4.99	1006	4,582	5.27	1042	4,860	5.59
8,000	971	4,637	5.33	996	4,829	5.55	1024	5,046	5.80	1055	5,290	6.08	1088	5,562	6.40
8,500	1029	5,421	6.24	1052	5,617	6.46	1078	5,835	6.71	1106	6,077	6.99	1136	6,345	7.30
9,000	1087	6,285	7.23	1108	6,484	7.46	1132	6,703	7.71	1158	6,946	7.99	1185	7,211	8.29
9,500	1145	7,231	8.32	1165	7,433	8.55	1187	7,655	8.80	1211	7,898	9.08	1236	8,161	9.39
10,000	1203	8,262	9.50	1222	8,468	9.74	1243	8,693	10.00	1265	8,936	10.28	1288	9,199	10.58
10,500	1261	9,381	10.79	1279	9,592	11.03	1299	9,820	11.29	1319	10,065	11.58	1341	10,327	11.88
11,000	1320	10,592	12.18	1337	10,807	12.43	1355	11,038	12.70	1374	11,284	12.98	1394	11,547	13.28
11,500	1378	11,896	13.68	—	—	—	—	—	—	—	—	—	—	—	—
12,000	—	—	—	—	—	—	—	—	—	—	—	—	—	—	—
12,500	—	—	—	—	—	—	—	—	—	—	—	—	—	—	—

AIRFLOW (Cfm)	EXTERNAL STATIC PRESSURE (in. wg)														
	1.2			1.4			1.6			1.8			2.0		
	Rpm	Bhp	Watts	Rpm	Bhp	Watts	Rpm	Bhp	Watts	Rpm	Bhp	Watts	Rpm	Bhp	Watts
6,500	1005	4,020	4.62	1052	4,390	5.05	1100	4,791	5.51	1148	5,221	6.00	1195	5673	6.52
7,000	1041	4,555	5.24	1084	4,908	5.64	1128	5,294	6.09	1172	5,710	6.57	1217	6153	7.08
7,500	1080	5,168	5.94	1119	5,508	6.33	1160	5,878	6.76	1201	6,279	7.22	1242	6708	7.71
8,000	1122	5,862	6.74	1158	6,190	7.12	1195	6,548	7.53	1233	6,934	7.97	1272	7347	8.45
8,500	1167	6,638	7.63	1200	6,959	8.00	1234	7,305	8.40	1269	7,677	8.83	1304	8076	9.29
9,000	1214	7,499	8.63	1244	7,813	8.99	1275	8,149	9.37	1308	8,511	9.79	1340	8896	10.23
9,500	1262	8,447	9.72	1290	8,754	10.07	1319	9,084	10.45	1349	9,437	10.85	1379	9812	11.28
10,000	1312	9,482	10.91	1338	9,785	11.25	1365	10,110	11.63	1392	10,454	12.02	—	—	—
10,500	1363	10,608	12.20	1387	10,909	12.55	—	—	—	—	—	—	—	—	—
11,000	—	—	—	—	—	—	—	—	—	—	—	—	—	—	—
11,500	—	—	—	—	—	—	—	—	—	—	—	—	—	—	—
12,000	—	—	—	—	—	—	—	—	—	—	—	—	—	—	—
12,500	—	—	—	—	—	—	—	—	—	—	—	—	—	—	—

**LEGEND**

**Bhp** — Brake Horsepower Input to Fan  
**Watts** — Input Watts to Motor

\*Motor drive ranges:  
 Low Range: 687-873  
 Mid-Low Range: 805-1007  
 Mid-High Range: 941-1176  
 High Range: 1014-1297  
 All other rpms require field-supplied drive.

Refer to page 27 for general Fan Performance Data notes.

NOTE: Maximum continuous bhp is:  
 Low Range: 5.75  
 Mid-Low Range: 5.75  
 Mid-High Range: 8.63  
 High Range: 11.50

**Table 23 — Power Exhaust Fan Performance**

AIRFLOW (Cfm)	LOW SPEED						MEDIUM SPEED						HIGH SPEED					
	208 V			230,460,575 V			208 V			230,460,575 V			208 V			230,460,575 V		
	ESP	Bhp	Watts	ESP	Bhp	Watts	ESP	Bhp	Watts	ESP	Bhp	Watts	ESP	Bhp	Watts	ESP	Bhp	Watts
3250	0.32	1.41	1580	0.70	1.49	1670	—	—	—	—	—	—	—	—	—	—	—	—
3350	0.23	1.44	1610	0.63	1.52	1700	0.60	1.51	1690	0.82	1.62	1810	—	—	—	—	—	—
3450	0.17	1.46	1635	0.59	1.55	1730	0.55	1.54	1720	0.78	1.64	1840	—	—	—	—	—	—
3550	0.13	1.47	1645	0.56	1.56	1745	0.49	1.56	1750	0.73	1.67	1870	—	—	—	—	—	—
3650	0.09	1.49	1665	0.53	1.58	1765	0.43	1.59	1780	0.68	1.70	1900	—	—	—	—	—	—
3750	—	—	—	0.51	1.60	1790	0.39	1.62	1815	0.64	1.72	1930	—	—	—	—	—	—
3850	—	—	—	0.48	1.62	1810	0.33	1.64	1835	0.59	1.74	1950	0.60	1.85	2070	0.73	1.99	2230
3950	—	—	—	0.45	1.64	1835	0.27	1.66	1860	0.54	1.76	1975	0.56	1.87	2095	0.69	2.01	2255
4050	—	—	—	0.40	1.67	1865	0.22	1.68	1885	0.49	1.79	2000	0.51	1.89	2120	0.65	2.04	2280
4250	—	—	—	—	—	—	0.17	1.74	1945	0.40	1.84	2060	0.41	1.92	2145	0.56	2.06	2310
4450	—	—	—	—	—	—	0.00	1.79	2005	0.30	1.89	2115	0.31	1.97	2205	0.47	2.12	2370
4650	—	—	—	—	—	—	—	—	—	0.22	1.94	2170	0.20	2.04	2280	0.37	2.19	2450
4850	—	—	—	—	—	—	—	—	—	0.16	1.98	2215	0.11	2.09	2335	0.30	2.24	2505
5050	—	—	—	—	—	—	—	—	—	0.12	2.02	2260	0.04	2.13	2385	0.23	2.28	2555
5250	—	—	—	—	—	—	—	—	—	—	—	—	—	—	—	0.17	2.33	2610
5450	—	—	—	—	—	—	—	—	—	—	—	—	—	—	—	0.12	2.38	2665
5650	—	—	—	—	—	—	—	—	—	—	—	—	—	—	—	0.07	2.40	2690
5850	—	—	—	—	—	—	—	—	—	—	—	—	—	—	—	0.04	2.42	2710

**LEGEND**

**Bhp** — Brake Horsepower  
**ESP** — External Static Pressure (in. wg)

**Table 24 — Operation Air Quantity Limits**

48HJ	COOLING		GAS HEAT	HEATING (Nat. Gas, Vertical) MINIMUM CFM	HEATING (Nat. Gas, Horizontal) MINIMUM CFM	HEATING (Propane, Vertical) MINIMUM CFM	HEATING (Propane, Horizontal) MINIMUM CFM
	Minimum Cfm	Maximum Cfm					
020	5,400	9,000	High Heat (8 Cell)	5,522	5,522	5,522	4,920
			Medium Heat (8 Cell)	4,977	4,977	4,480	4,480
			Low Heat (5 Cell)	4,218	4,218	4,218	3,796
024	5,500	10,000	High Heat (8 Cell)	5,522	5,522	5,522	4,920
			Medium Heat (8 Cell)	4,977	4,977	4,480	4,480
			Low Heat (5 Cell)	4,218	4,218	4,218	3,796
028	6,000	11,500	High Heat (8 Cell)	5,522	5,470*	5,522	4,920*
			Medium Heat (8 Cell)	4,977	4,977*	4,480	4,480*
			Low Heat (5 Cell)	4,218	4,218	4,218	3,796

\*7000 cfm minimum recommended above 1.0 in. wg external static pressure.

**Table 25 — Evaporator Fan Motor Specifications**

UNIT	DRIVE	ORIENTATION	MOTOR P/N	NOMINAL HP	VOLTAGE	MAX WATTS	EFFICIENCY %	MAX BHP	MAX BkW	MAX AMPS
48HJ020	Low	Vertical	N/A	N/A	208	N/A	N/A	N/A	N/A	N/A
			N/A	N/A	230	N/A	N/A	N/A	N/A	N/A
			N/A	N/A	460	N/A	N/A	N/A	N/A	N/A
			N/A	N/A	575	N/A	N/A	N/A	N/A	N/A
	Mid-Low	Vertical	HD60FK651	3.7	208	3698	85.8	4.25	3.17	10.6
			HD60FK651	3.7	230	3698	85.8	4.25	3.17	9.6
			HD60FK651	3.7	460	3698	85.8	4.25	3.17	4.8
			HD58DL575	3	575	3149	81.7	3.45	2.57	3.9
	Mid-High	Vertical	HD60FL650	5	208	4900	87.5	5.75	4.29	16.7
			HD60FL650	5	230	4900	87.5	5.75	4.29	15.2
			HD60FL650	5	460	4900	87.5	5.75	4.29	7.6
			HD60FL575	5	575	4900	87.5	5.75	4.29	6.1
	High	Vertical	HD62FL650	7.5	208	7267	88.5	8.63	6.43	24.2
			HD62FL650	7.5	230	7267	88.5	8.63	6.43	22
			HD62FL650	7.5	460	7267	88.5	8.63	6.43	11
			HD62FL575	7.5	575	7267	88.5	8.63	6.43	9
	Low	Horizontal	N/A	N/A	208	N/A	N/A	N/A	N/A	N/A
			N/A	N/A	230	N/A	N/A	N/A	N/A	N/A
			N/A	N/A	460	N/A	N/A	N/A	N/A	N/A
			N/A	N/A	575	N/A	N/A	N/A	N/A	N/A
	Mid-Low	Horizontal	HD60FK651	3.7	208	3698	85.8	4.25	3.17	10.6
			HD60FK651	3.7	230	3698	85.8	4.25	3.17	9.6
			HD60FK651	3.7	460	3698	85.8	4.25	3.17	4.8
			HD58DL575	3	575	3149	81.7	3.45	2.57	3.9
	Mid-High	Horizontal	HD60FL650	5	208	4900	87.5	5.75	4.29	16.7
			HD60FL650	5	230	4900	87.5	5.75	4.29	15.2
			HD60FL650	5	460	4900	87.5	5.75	4.29	7.6
			HD60FL575	5	575	4900	87.5	5.75	4.29	6.1
	High	Horizontal	HD62FL650	7.5	208	7267	88.5	8.63	6.43	24.2
			HD62FL650	7.5	230	7267	88.5	8.63	6.43	22
			HD62FL650	7.5	460	7267	88.5	8.63	6.43	11
			HD62FL575	7.5	575	7267	88.5	8.63	6.43	9

LEGEND

BHP — Brake Horsepower  
BkW — Brake Kilowatts

**Table 25 — Evaporator Fan Motor Specifications (cont)**

UNIT	DRIVE	ORIENTATION	MOTOR P/N	NOMINAL HP	VOLTAGE	MAX WATTS	EFFICIENCY %	MAX BHP	MAX BkW	MAX AMPS	
48HJ024	Low	Vertical	HD60FK651	3.7	208	3698	85.8	4.25	3.17	10.6	
			HD60FK651	3.7	230	3698	85.8	4.25	3.17	9.6	
			HD60FK651	3.7	460	3698	85.8	4.25	3.17	4.8	
			HD60FL575	5	575	4900	87.5	5.75	4.29	6.1	
	Mid-Low	Vertical	HD60FL650	5	208	4900	87.5	5.75	4.29	16.7	
			HD60FL650	5	230	4900	87.5	5.75	4.29	15.2	
			HD60FL650	5	460	4900	87.5	5.75	4.29	7.6	
			HD60FL575	5	575	4900	87.5	5.75	4.29	6.1	
	Mid-High	Vertical	HD62FL650	7.5	208	7267	88.5	8.63	6.43	24.2	
			HD62FL650	7.5	230	7267	88.5	8.63	6.43	22	
			HD62FL650	7.5	460	7267	88.5	8.63	6.43	11	
			HD62FL575	7.5	575	7267	88.5	8.63	6.43	9	
	High	Vertical	HD64FL650	10	208	9582	89.5	11.5	8.58	30.8	
			HD64FL650	10	230	9582	89.5	11.5	8.58	28	
			HD64FL650	10	460	9582	89.5	11.5	8.58	14	
			HD64FL575	10	575	9582	89.5	11.5	8.58	11	
	Low	Horizontal	N/A	N/A	208	N/A	N/A	N/A	N/A	N/A	N/A
			N/A	N/A	230	N/A	N/A	N/A	N/A	N/A	N/A
			N/A	N/A	460	N/A	N/A	N/A	N/A	N/A	N/A
			N/A	N/A	575	N/A	N/A	N/A	N/A	N/A	N/A
	Mid-Low	Horizontal	HD60FK651	3.7	208	3698	85.8	4.25	3.17	10.6	
			HD60FK651	3.7	230	3698	85.8	4.25	3.17	9.6	
			HD60FK651	3.7	460	3698	85.8	4.25	3.17	4.8	
			HD60FL575	5	575	4900	87.5	5.75	4.29	6.1	
	Mid-High	Horizontal	HD60FL650	5	208	4900	87.5	5.75	4.29	16.7	
			HD60FL650	5	230	4900	87.5	5.75	4.29	15.2	
			HD60FL650	5	460	4900	87.5	5.75	4.29	7.6	
			HD60FL575	5	575	4900	87.5	5.75	4.29	6.1	
	High	Horizontal	HD62FL650	7.5	208	7267	88.5	8.63	6.43	24.2	
			HD62FL650	7.5	230	7267	88.5	8.63	6.43	22	
			HD62FL650	7.5	460	7267	88.5	8.63	6.43	11	
			HD62FL575	7.5	575	7267	88.5	8.63	6.43	9	
48HJ028	Low	Vertical	HD60FL650	5	208	4900	87.5	5.75	4.29	16.7	
			HD60FL650	5	230	4900	87.5	5.75	4.29	15.2	
			HD60FL650	5	460	4900	87.5	5.75	4.29	7.6	
			HD60FL575	5	575	4900	87.5	5.75	4.29	6.1	
	Mid-Low	Vertical	HD60FL650	5	208	4900	87.5	5.75	4.29	16.7	
			HD60FL650	5	230	4900	87.5	5.75	4.29	15.2	
			HD60FL650	5	460	4900	87.5	5.75	4.29	7.6	
			HD60FL575	5	575	4900	87.5	5.75	4.29	6.1	
	Mid-High	Vertical	HD62FL650	7.5	208	7267	88.5	8.63	6.43	24.2	
			HD62FL650	7.5	230	7267	88.5	8.63	6.43	22	
			HD62FL650	7.5	460	7267	88.5	8.63	6.43	11	
			HD62FL575	7.5	575	7267	88.5	8.63	6.43	9	
	High	Vertical	HD64FL650	10	208	9582	89.5	11.5	8.58	30.8	
			HD64FL650	10	230	9582	89.5	11.5	8.58	28	
			HD64FL650	10	460	9582	89.5	11.5	8.58	14	
			HD64FL575	10	575	9582	89.5	11.5	8.58	11	
	Low	Horizontal	HD60FL650	5	208	4900	87.5	5.75	4.29	16.7	
			HD60FL650	5	230	4900	87.5	5.75	4.29	15.2	
			HD60FL650	5	460	4900	87.5	5.75	4.29	7.6	
			HD60FL575	5	575	4900	87.5	5.75	4.29	6.1	
	Mid-Low	Horizontal	HD60FL650	5	208	4900	87.5	5.75	4.29	16.7	
			HD60FL650	5	230	4900	87.5	5.75	4.29	15.2	
			HD60FL650	5	460	4900	87.5	5.75	4.29	7.6	
			HD60FL575	5	575	4900	87.5	5.75	4.29	6.1	
	Mid-High	Horizontal	HD62FL650	7.5	208	7267	88.5	8.63	6.43	24.2	
			HD62FL650	7.5	230	7267	88.5	8.63	6.43	22	
			HD62FL650	7.5	460	7267	88.5	8.63	6.43	11	
			HD62FL575	7.5	575	7267	88.5	8.63	6.43	9	
High	Horizontal	HD64FL650	10	208	9582	89.5	11.5	8.58	30.8		
		HD64FL650	10	230	9582	89.5	11.5	8.58	28		
		HD64FL650	10	460	9582	89.5	11.5	8.58	14		
		HD64FL575	10	575	9582	89.5	11.5	8.58	11		

**LEGEND**

**BHP** — Brake Horsepower  
**BkW** — Brake Kilowatts

**Table 26 — Accessory/FIOP EconoMiSer IV Static Pressure (in. wg)\***

COMPONENT	CFM								
	4,000	4,500	5,000	5,500	6,000	6,500	7,000	7,500	8,000
EconoMiSer IV	0.02	0.03	0.04	0.05	0.06	0.07	0.08	0.09	0.10

COMPONENT	CFM							
	8,500	9,000	9,500	10,000	10,500	11,000	11,500	12,000
EconoMiSer IV	0.11	0.12	0.13	0.15	0.16	0.17	0.19	0.20

**LEGEND**

**FIOP** — Factory-Installed Option

\*The static pressure must be added to the external static pressure. The sum and the evaporator entering-air cfm should then be used in conjunction with the Fan Performance tables to determine blower rpm and watts.

**Table 27 — Fan Rpm at Motor Pulley Settings\***

48HJ	DRIVE	MOTOR PULLEY TURNS OPEN													
		0	1/2	1	1 1/2	2	2 1/2	3	3 1/2	4	4 1/2	5	5 1/2	6	
020 (208/230 and 460 volt)	Low Range Vertical	N/A	N/A	N/A	N/A	N/A	N/A	N/A	N/A	N/A	N/A	N/A	N/A	N/A	N/A
	Mid-Low Range Vertical	647	667	687	707	727	747	767	786	806	826	846	866	886	
	Mid-High Range Vertical	897	917	937	958	978	998	1018	1038	1058	1079	1099	1119	1139	
	High Range Vertical	1078	1094	1111	1127	1143	1160	1176	1192	1209	1225	1241	1258	1274	
	Low Range Horizontal	N/A	N/A	N/A	N/A	N/A	N/A	N/A	N/A	N/A	N/A	N/A	N/A	N/A	
	Mid-Low Range Horizontal	896	924	951	979	1006	1034	1062	1089	1117	1144	1172	1199	1227	
	Mid-High Range Horizontal	1113	1138	1163	1188	1213	1238	1264	1289	1314	1339	1364	1389	1414	
	High Range Horizontal	1096	1116	1137	1157	1177	1197	1218	1238	1258	1278	1299	1319	1339	
020 (575 volt)	Low Range Vertical	N/A	N/A	N/A	N/A	N/A	N/A	N/A	N/A	N/A	N/A	N/A	N/A	N/A	
	Mid-Low Range Vertical	810	832	854	876	897	919	941	963	985	1007	1028	1050	1072	
	Mid-High Range Vertical	873	893	912	932	951	971	991	1010	1030	1049	1069	1088	1108	
	High Range Vertical	1078	1094	1111	1127	1143	1160	1176	1192	1209	1225	1241	1258	1274	
	Low Range Horizontal	N/A	N/A	N/A	N/A	N/A	N/A	N/A	N/A	N/A	N/A	N/A	N/A	N/A	
	Mid-Low Range Horizontal	863	886	909	933	956	979	1002	1025	1048	1072	1095	1118	1141	
	Mid-High Range Horizontal	1042	1062	1083	1103	1123	1143	1164	1184	1204	1224	1245	1265	1285	
	High Range Horizontal	1096	1116	1137	1157	1177	1197	1218	1238	1258	1278	1299	1319	1339	
024 (208/230 and 460 volt)	Low Range Vertical	685	706	727	749	770	791	812	833	854	876	897	918	939	
	Mid-Low Range Vertical	949	970	992	1013	1035	1056	1078	1099	1120	1142	1163	1185	1206	
	Mid-High Range Vertical	941	961	980	1000	1019	1039	1059	1078	1098	1117	1137	1156	1176	
	High Range Vertical	1014	1038	1061	1085	1108	1132	1156	1179	1203	1226	1250	1273	1297	
	Low Range Horizontal	N/A	N/A	N/A	N/A	N/A	N/A	N/A	N/A	N/A	N/A	N/A	N/A	N/A	
	Mid-Low Range Horizontal	896	924	951	979	1006	1034	1062	1089	1117	1144	1172	1199	1227	
	Mid-High Range Horizontal	1113	1138	1163	1188	1213	1238	1264	1289	1314	1339	1364	1389	1414	
	High Range Horizontal	1096	1116	1137	1157	1177	1197	1218	1238	1258	1278	1299	1319	1339	
024 (575 volt)	Low Range Vertical	751	768	785	802	819	836	853	869	886	903	920	937	954	
	Mid-Low Range Vertical	949	970	992	1013	1035	1056	1078	1099	1120	1142	1163	1185	1206	
	Mid-High Range Vertical	941	961	980	1000	1019	1039	1059	1078	1098	1117	1137	1156	1176	
	High Range Vertical	1014	1038	1061	1085	1108	1132	1156	1179	1203	1226	1250	1273	1297	
	Low Range Horizontal	N/A	N/A	N/A	N/A	N/A	N/A	N/A	N/A	N/A	N/A	N/A	N/A	N/A	
	Mid-Low Range Horizontal	873	893	912	932	951	971	991	1010	1030	1049	1069	1088	1108	
	Mid-High Range Horizontal	1113	1138	1163	1188	1213	1238	1264	1289	1314	1339	1364	1389	1414	
	High Range Horizontal	1096	1116	1137	1157	1177	1197	1218	1238	1258	1278	1299	1319	1339	
028 (all voltages)	Low Range Vertical	687	703	718	734	749	765	780	796	811	827	842	858	873	
	Mid-Low Range Vertical	805	822	839	856	872	889	906	923	940	957	973	990	1007	
	Mid-High Range Vertical	941	961	980	1000	1019	1039	1059	1078	1098	1117	1137	1156	1176	
	High Range Vertical	1014	1038	1061	1085	1108	1132	1156	1179	1203	1226	1250	1273	1297	
	Low Range Horizontal	687	703	718	734	749	765	780	796	811	827	842	858	873	
	Mid-Low Range Horizontal	805	822	839	856	872	889	906	923	940	957	973	990	1007	
	Mid-High Range Horizontal	941	961	980	1000	1019	1039	1059	1078	1098	1117	1137	1156	1176	
	High Range Horizontal	1014	1038	1061	1085	1108	1132	1156	1179	1203	1226	1250	1273	1297	

\*Approximate fan rpm shown.

**Optional EconoMiSer IV** — See Fig. 23 for EconoMiSer IV component locations. The optional EconoMiSer IV comes from the factory fully wired and assembled. No field wiring or assembly is required for standard outdoor dry bulb changeover operation. Field wiring of accessory sensors is required for different operational modes.

**ECONOMISER IV STANDARD SENSORS**

**Outdoor Air Temperature (OAT) Sensor** — The outdoor air temperature sensor (HH57AC074) is a 10 to 20 mA device used to measure the outdoor-air temperature. The outdoor-air temperature is used to determine when the EconoMiSer IV can be used for free cooling. The sensor is factory-installed on the EconoMiSer IV in the outdoor airstream. See Fig. 24. The operating range of temperature measurement is 40 to 100 F.

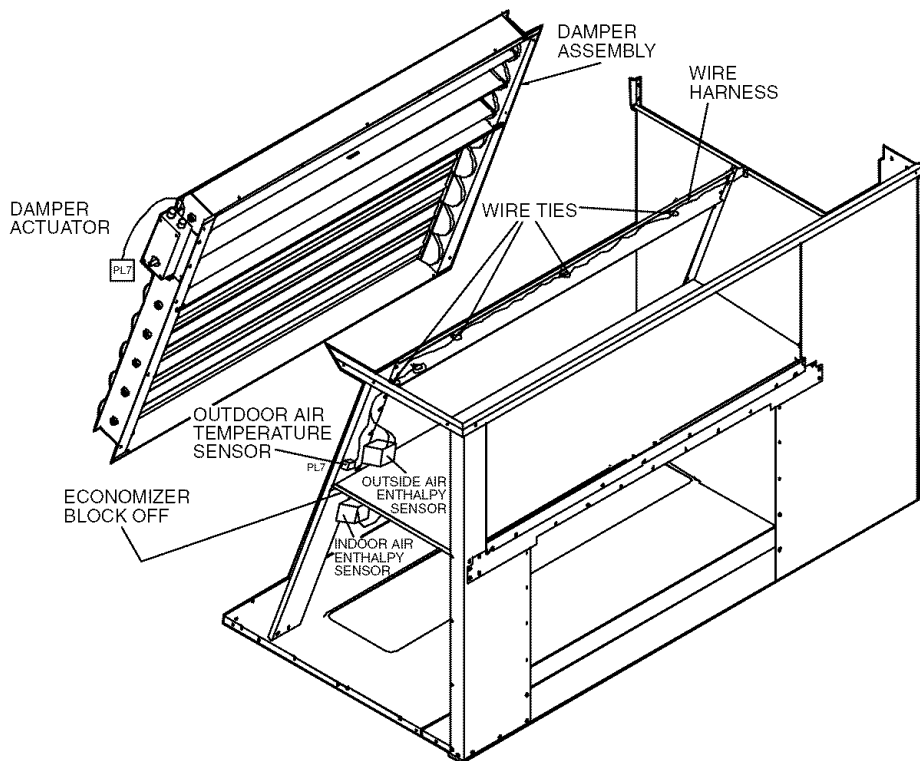
**Supply-Air Temperature (SAT) Sensor** — The supply-air temperature sensor is a 3 K thermistor located at the outlet of the indoor fan. See Fig. 24. This sensor is factory installed. The operating range of temperature measurement is 0° to 158 F.

The temperature sensor is a short probe with blue wires running to it.

**Outdoor Air Lockout Sensor** — The EconoMiSer IV is equipped with an ambient temperature lockout switch located in the outdoor airstream which is used to lock out the compressors below a 42 F ambient temperature.

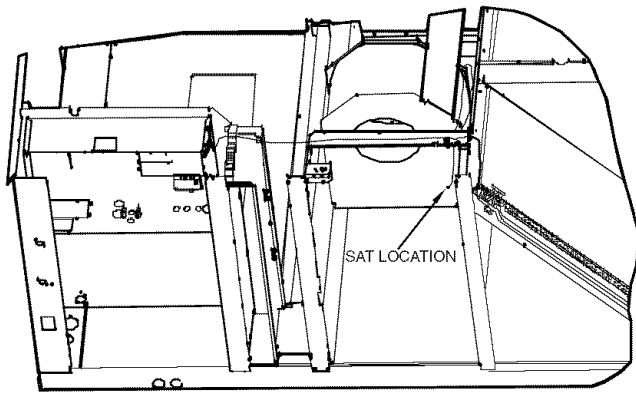
**ECONOMISER IV CONTROLLER WIRING AND OPERATIONAL MODES** — Determine the EconoMiSer IV control mode before set up of the control. Some modes of operation may require different sensors. Refer to Table 28. The EconoMiSer IV is supplied from the factory with a supply-air temperature sensor and an outdoor air temperature sensor. This allows for operation of the EconoMiSer IV with outdoor air dry bulb changeover control. Additional accessories can be added to allow for different types of changeover control and operation of the EconoMiSer IV and unit.

**Outdoor Dry Bulb Changeover** — The standard controller is shipped from the factory configured for outdoor dry bulb changeover control. The outdoor air and supply-air temperature sensors are included as standard. For this control mode, the outdoor temperature is compared to an adjustable set point selected on the control. If the outdoor-air temperature is above the set point, the EconoMiSer IV will adjust the outdoor-air dampers to minimum position. If the outdoor-air temperature is below the set point, the position of the outdoor-air dampers will be controlled to provide free cooling using outdoor air. When in this mode, the LED next to the free cooling set point potentiometer will be on. The changeover temperature set point is controlled by the free cooling set point potentiometer located on the control. The scale on the potentiometer is A, B, C, and D. See Fig. 25 for the corresponding temperature changeover values.

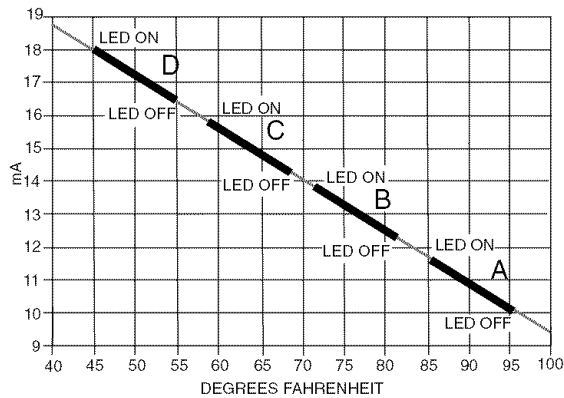


**Fig. 23 — EconoMiSer IV Component Locations (Exploded View)**





**Fig. 24 — Supply Air Temperature Sensor Location**



**Fig. 25 — Outdoor Air Temperature Changeover Set Points**

**Differential Dry Bulb Control** — For differential dry bulb control the standard outdoor dry bulb sensor is used in conjunction with an additional accessory dry bulb sensor (part number CRTEMPSN002A00). The accessory sensor must be mounted in the return airstream. Wiring is provided in the EconoMi\$er IV wiring harness. See Fig. 26.

In this mode of operation, the outdoor-air temperature is compared to the return-air temperature and the lower temperature airstream is used for cooling. When using this mode of

changeover control, turn the enthalpy set point potentiometer fully clockwise to the D setting.

**Outdoor Enthalpy Changeover** — For enthalpy control, accessory enthalpy sensor (part number HH57AC078) is required. Replace the standard outdoor dry bulb temperature sensor with the accessory enthalpy sensor in the same mounting location. When the outdoor air enthalpy rises above the outdoor enthalpy changeover set point, the outdoor-air damper moves to its minimum position. The outdoor enthalpy changeover set point is set with the outdoor enthalpy set point potentiometer on the EconoMi\$er IV controller. The set points are A, B, C, and D. See Fig. 27. The factory-installed 620-ohm jumper must be in place across terminals S<sub>R</sub> and + on the EconoMi\$er IV controller. See Fig. 26.

**Differential Enthalpy Control** — For differential enthalpy control, the EconoMi\$er IV controller uses two enthalpy sensors (HH57AC078 and CRENTDIF004A00), one in the outside air and one in the return air duct. The EconoMi\$er IV controller compares the outdoor air enthalpy to the return air enthalpy to determine EconoMi\$er IV use. The controller selects the lower enthalpy air (return or outdoor) for cooling. For example, when the outdoor air has a lower enthalpy than the return air, the EconoMi\$er IV opens to bring in outdoor air for free cooling.

Replace the standard outside air dry bulb temperature sensor with the accessory enthalpy sensor in the same mounting location. Mount the return air enthalpy sensor in the return air duct. Wiring is provided in the EconoMi\$er IV wiring harness. See Fig. 26. The outdoor enthalpy changeover set point is set with the outdoor enthalpy set point potentiometer on the EconoMi\$er IV controller. When using this mode of changeover control, turn the enthalpy set point potentiometer fully clockwise to the D setting. See Fig. 28.

**Indoor Air Quality (IAQ) Sensor Input** — The IAQ input can be used for demand controlled ventilation control based on the level of CO<sub>2</sub> measured in the space or return air duct.

Mount the optional IAQ sensor according to manufacturer specifications. The IAQ sensor should be wired to the AQ and AQ1 terminals of the controller. Adjust the DCV (demand controlled ventilation) potentiometers to correspond to the DCV voltage output of the indoor air quality sensor at the user-determined set point. See Fig. 29.

If a separate field-supplied transformer is used to power the IAQ sensor, the sensor must not be grounded or the EconoMi\$er IV control board will be damaged.

**Table 28 — EconoMi\$er IV Sensor Usage**

APPLICATION	ECONOMISER IV WITH OUTDOOR AIR DRY BULB SENSOR			ECONOMISER IV WITH SINGLE ENTHALPY SENSOR		
	Accessories Required			Accessories Required		
Outdoor Air Dry Bulb	None. The outdoor air dry bulb sensor is factory installed.			CRTEMPSN002A00*		
Differential Dry Bulb	CRTEMPSN002A00*			(2) CRTEMPSN002A00*		
Single Enthalpy	HH57AC078			None. The single enthalpy sensor is factory installed.		
Differential Enthalpy	HH57AC078 and CRENTDIF004A00*			CRENTDIF004A00*		
CO <sub>2</sub> for DCV Control using a Wall-Mounted CO <sub>2</sub> Sensor	33ZCSENCO2			33ZCSENCO2		
CO <sub>2</sub> for DCV Control using a Duct-Mounted CO <sub>2</sub> Sensor	33ZCSENCO2† and 33ZCASPCO2**	⌘ O	CRCBDIOX005A00††	33ZCSENCO2† and 33ZCASPCO2**	⌘ O	CRCBDIOX005A00††

\*CRENTDIF004A00 and CRTEMPSN002A00 accessories are used on many different base units. As such, these kits may contain parts that will not be needed for installation.

†33ZCSENCO2 is an accessory CO<sub>2</sub> sensor.

\*\*33ZCASPCO2 is an accessory aspirator box required for duct-mounted applications.

††CRCBDIOX005A00 is an accessory that contains both 33ZCSENCO2 and 33ZCASPCO2 accessories.

**Exhaust Set Point Adjustment** — The exhaust set point will determine when the exhaust fan runs based on damper position (if accessory power exhaust is installed). The set point is modified with the Exhaust Fan Set Point (EXH SET) potentiometer. See Fig. 28. The set point represents the damper position above which the exhaust fans will be turned on. When there is a call for exhaust, the EconoMiSer IV controller provides a  $45 \pm 15$  second delay before exhaust fan activation to allow the dampers to open. This delay allows the damper to reach the appropriate position to avoid unnecessary fan overload.

**Minimum Position Control** — There is a minimum damper position potentiometer on the EconoMiSer IV controller. See Fig. 28. The minimum damper position maintains the minimum airflow into the building during the occupied period.

When using demand ventilation, the minimum damper position represents the minimum ventilation position for VOC (volatile organic compounds) ventilation requirements. The maximum demand ventilation position is used for fully occupied ventilation.

When demand ventilation control is not being used, the minimum position potentiometer should be used to set the occupied ventilation position. The maximum demand ventilation position should be turned fully clockwise.

Adjust the minimum position potentiometer to allow the minimum amount of outdoor air, as required by local codes, to enter the building. Make minimum position adjustments with at least  $10^\circ$  F temperature difference between the outdoor and return-air temperatures. To determine the minimum position setting, perform the following procedure:

1. Calculate the appropriate mixed-air temperature using the following formula:

$$(T_O \times \frac{OA}{100}) + (T_R \times \frac{RA}{100}) = T_M$$

$T_O$  = Outdoor-Air Temperature

OA = Percent of Outdoor Air

$T_R$  = Return-Air Temperature

RA = Percent of Return Air

$T_M$  = Mixed-Air Temperature

As an example, if local codes require 10% outdoor air during occupied conditions, outdoor-air temperature is 60 F, and return-air temperature is 75 F.

$$(60 \times .10) + (75 \times .90) = 73.5 \text{ F}$$

2. Disconnect the supply air sensor from terminals T and T1.
3. Ensure that the factory-installed jumper is in place across terminals P and P1. If remote damper positioning is being used, make sure that the terminals are wired according to Fig. 26 and that the minimum position potentiometer is turned fully clockwise.
4. Connect 24 vac across terminals TR and TR1.
5. Carefully adjust the minimum position potentiometer until the measured mixed-air temperature matches the calculated value.
6. Reconnect the supply-air sensor to terminals T and T1.

Remote control of the EconoMiSer IV damper is desirable when requiring additional temporary ventilation. If a field-supplied remote potentiometer (Honeywell part number S963B1128) is wired to the EconoMiSer IV controller, the minimum position of the damper can be controlled from a remote location.

To control the minimum damper position remotely, remove the factory-installed jumper on the P and P1 terminals on the EconoMiSer IV controller. Wire the field-supplied potentiometer to the P and P1 terminals on the EconoMiSer IV controller. See Fig. 26.

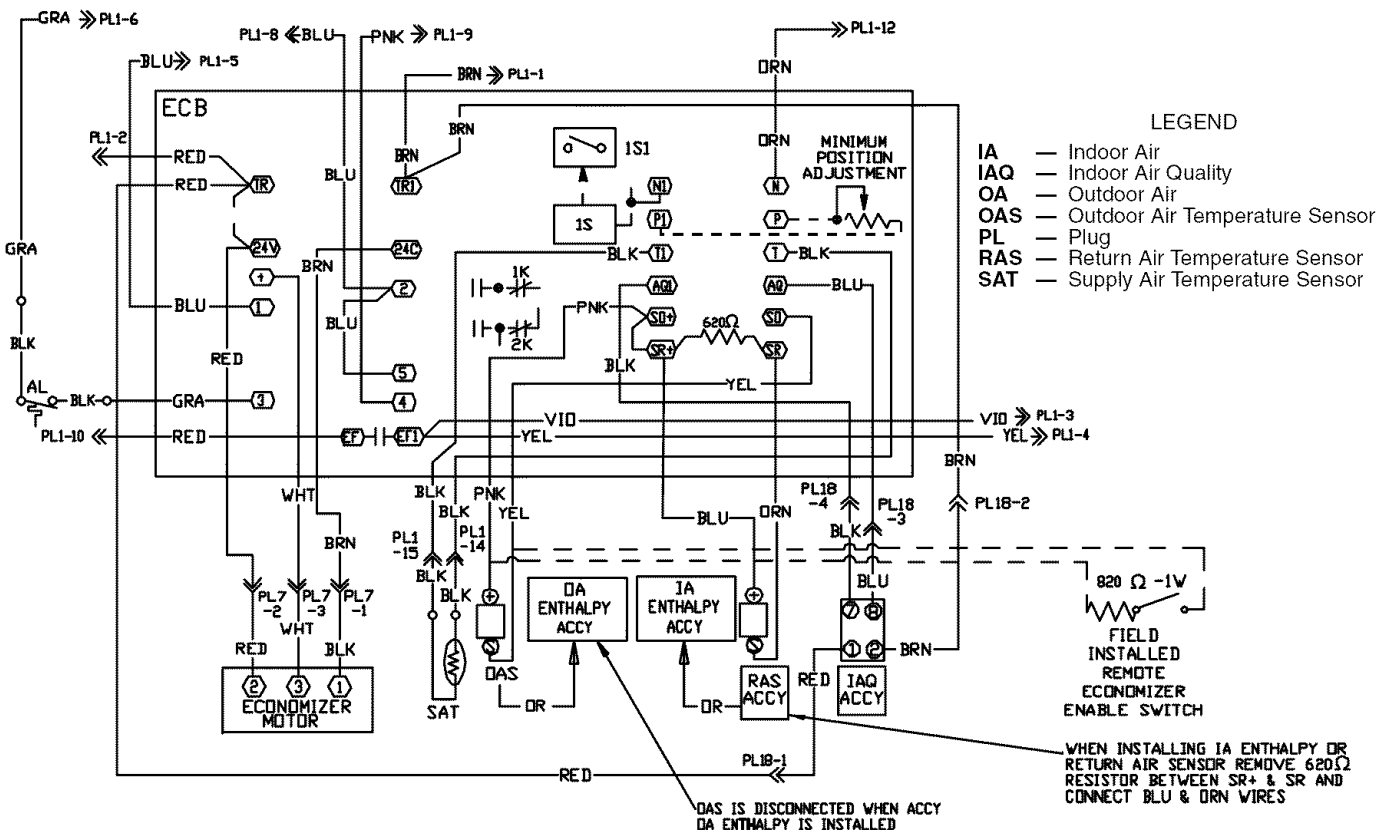


Fig. 26 — EconoMiSer IV Wiring

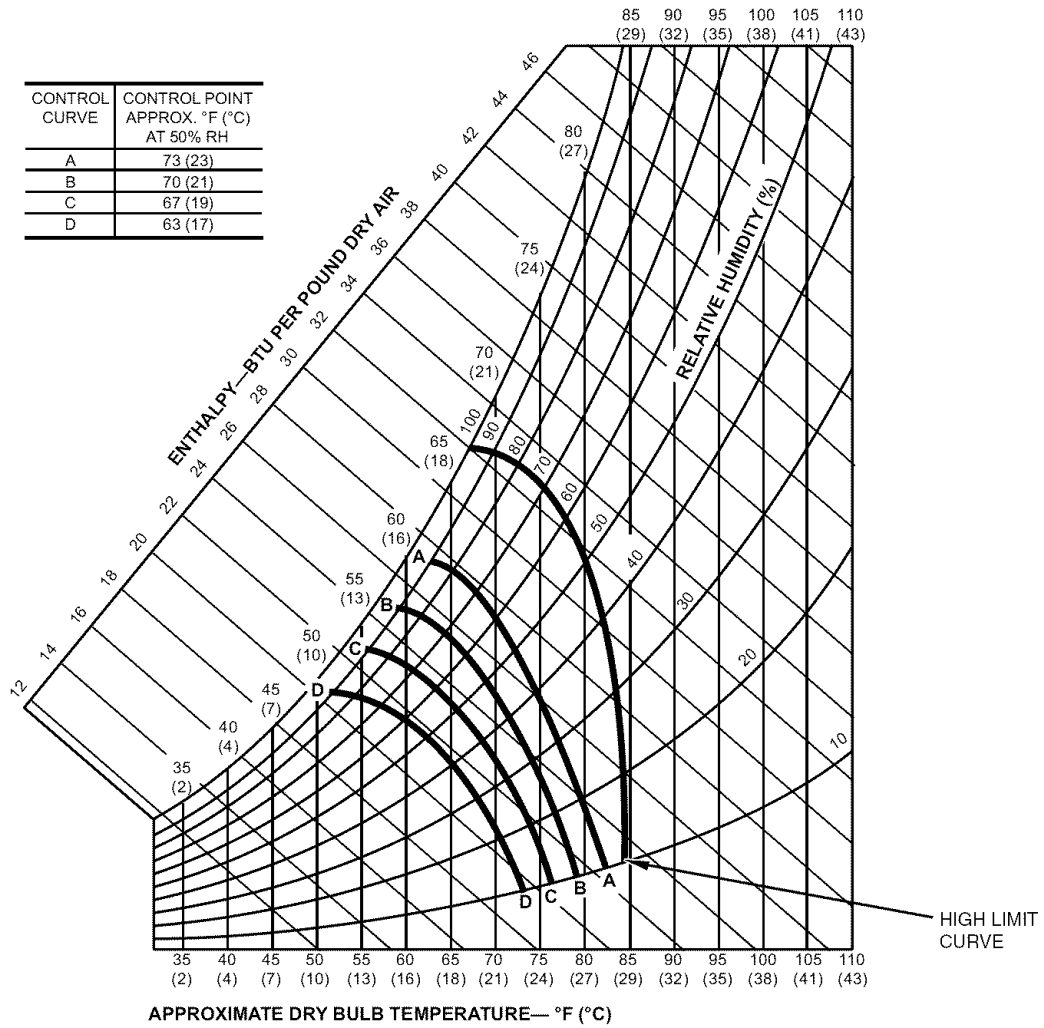


Fig. 27 — Enthalpy Changeover Set Points

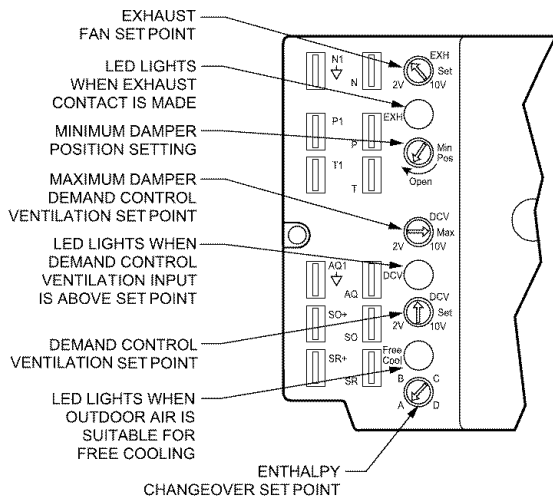


Fig. 28 — EconMiSer IV Controller Potentiometer and LED Locations

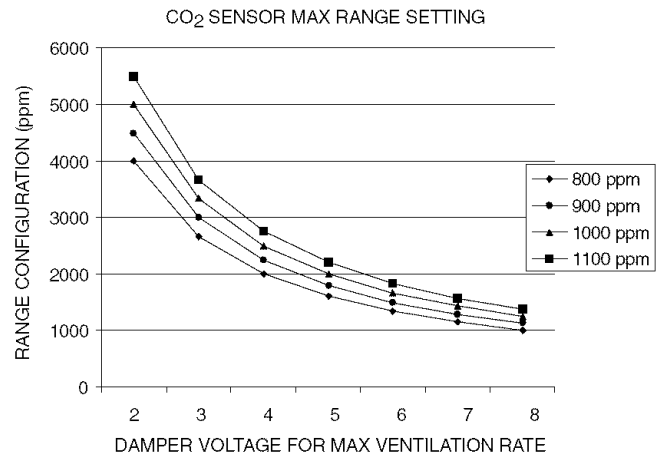


Fig. 29 — CO<sub>2</sub> Sensor Maximum Range Setting

**Damper Movement** — Damper movement from full open to full closed (or vice versa) takes up to 2½ minutes.

**Thermostats** — The EconoMi\$er IV control works with conventional thermostats that have a Y1 (cool stage 1), Y2 (cool stage 2), W1 (heat stage 1), W2 (heat stage 2), and G (fan). The EconoMi\$er IV control does not support space temperature sensors like the T55 or T56. Connections are made at the thermostat terminal connection board located in the main control box.

**Occupancy Control** — The factory default configuration for the EconoMi\$er IV control is occupied mode. Occupied status is provided by the black jumper from terminal TR to terminal N. When unoccupied mode is desired, install a field-supplied timeclock function in place of the jumper between TR and N. See Fig. 26. When the timeclock contacts are closed, the EconoMi\$er IV control will be in occupied mode. When the timeclock contacts are open (removing the 24-v signal from terminal N), the EconoMi\$er IV will be in unoccupied mode.

**Demand Control Ventilation** — When using the EconoMi\$er IV for demand control ventilation, there are some equipment selection criteria which should be considered. When selecting the heat capacity and cool capacity of the equipment, the maximum ventilation rate must be evaluated for design conditions. The maximum damper position must be calculated to provide the desired fresh air.

Typically the maximum ventilation rate will be about 5 to 10% more than the typical cfm required per person, using normal outside air design criteria.

A proportional anticipatory strategy should be taken with the following conditions: a zone with a large area, varied occupancy, and equipment that cannot exceed the required ventilation rate at design conditions. Exceeding the required ventilation rate means the equipment can condition air at a maximum ventilation rate that is greater than the required ventilation rate for maximum occupancy. A proportional-anticipatory strategy will cause the fresh air supplied to increase as the room CO<sub>2</sub> level increases even though the CO<sub>2</sub> set point has not been reached. By the time the CO<sub>2</sub> level reaches the set point, the damper will be at maximum ventilation and should maintain the set point.

In order to have the CO<sub>2</sub> sensor control the economizer damper in this manner, first determine the damper voltage output for minimum or base ventilation. Base ventilation is the ventilation required to remove contaminants during unoccupied periods. The following equation may be used to determine the percent of outside-air entering the building for a given damper position. For best results there should be at least a 10 degree difference in outside and return-air temperatures.

$$(T_O \times \frac{OA}{100}) + (T_R \times \frac{RA}{100}) = T_M$$

T<sub>O</sub> = Outdoor-Air Temperature  
OA = Percent of Outdoor Air  
T<sub>R</sub> = Return-Air Temperature  
RA = Percent of Return Air  
T<sub>M</sub> = Mixed-Air Temperature

Once base ventilation has been determined, set the minimum damper position potentiometer to the correct position.

The same equation can be used to determine the occupied or maximum ventilation rate to the building. For example, an output of 3.6 volts to the actuator provides a base ventilation

rate of 5% and an output of 6.7 volts provides the maximum ventilation rate of 20% (or base plus 15 cfm per person). Use Fig. 29 to determine the maximum setting of the CO<sub>2</sub> sensor. For example, a 1100 ppm set point relates to a 15 cfm per person design. Use the 1100 ppm curve on Fig. 29 to find the point when the CO<sub>2</sub> sensor output will be 6.7 volts. Line up the point on the graph with the left side of the chart to determine that the range configuration for the CO<sub>2</sub> sensor should be 1800 ppm. The EconoMi\$er IV controller will output the 6.7 volts from the CO<sub>2</sub> sensor to the actuator when the CO<sub>2</sub> concentration in the space is at 1100 ppm. The DCV set point may be left at 2 volts since the CO<sub>2</sub> sensor voltage will be ignored by the EconoMi\$er IV controller until it rises above the 3.6 volt setting of the minimum position potentiometer.

Once the fully occupied damper position has been determined, set the maximum damper demand control ventilation potentiometer to this position. Do not set to the maximum position as this can result in over-ventilation to the space and potential high-humidity levels.

**CO<sub>2</sub> Sensor Configuration** — The CO<sub>2</sub> sensor has preset standard voltage settings that can be selected anytime after the sensor is powered up. See Table 29.

Use setting 1 or 2 for Carrier equipment. See Table 29.

1. Press Clear and Mode buttons. Hold at least 5 seconds until the sensor enters the Edit mode.
2. Press Mode twice. The STDSET Menu will appear.
3. Use the Up/Down button to select the preset number. See Table 29.
4. Press Enter to lock in the selection.
5. Press Mode to exit and resume normal operation.

The custom settings of the CO<sub>2</sub> sensor can be changed anytime after the sensor is energized. Follow the steps below to change the non-standard settings:

1. Press Clear and Mode buttons. Hold at least 5 seconds until the sensor enters the Edit mode.
2. Press Mode twice. The STDSET Menu will appear.
3. Use the Up/Down button to toggle to the NONSTD menu and press Enter.
4. Use the Up/Down button to toggle through each of the nine variables, starting with Altitude, until the desired setting is reached.
5. Press Mode to move through the variables.
6. Press Enter to lock in the selection, then press Mode to continue to the next variable.

**Dehumidification of Fresh Air with DCV Control** — Information from ASHRAE (American Society of Heating, Refrigeration, and Air Conditioning Engineers) indicates that the largest humidity load on any zone is the fresh air introduced. For some applications, a device such as a 62AQ energy recovery unit is added to reduce the moisture content of the fresh air being brought into the building when the enthalpy is high. In most cases, the normal heating and cooling processes are more than adequate to remove the humidity loads for most commercial applications.

If normal rooftop heating and cooling operation is not adequate for the outdoor humidity level, an energy recovery unit and/or a dehumidification option should be considered.

**Table 29 — CO<sub>2</sub> Sensor Standard Settings**

SETTING	EQUIPMENT	OUTPUT	VENTILATION RATE (cfm/Person)	ANALOG OUTPUT	CO <sub>2</sub> CONTROL RANGE (ppm)	OPTIONAL RELAY SETPOINT (ppm)	RELAY HYSTERESIS (ppm)
1	Interface w/Standard Building Control System	Proportional	Any	0-10V 4-20 mA	0-2000	1000	50
2		Proportional	Any	2-10V 7-20 mA	0-2000	1000	50
3		Exponential	Any	0-10V 4-20 mA	0-2000	1100	50
4	Economizer	Proportional	15	0-10V 4-20 mA	0-1100	1100	50
5		Proportional	20	0-10V 4-20 mA	0- 900	900	50
6		Exponential	15	0-10V 4-20 mA	0-1100	1100	50
7		Exponential	20	0-10V 4-20 mA	0- 900	900	50
8	Health & Safety	Proportional	—	0-10V 4-20 mA	0-9999	5000	500
9	Parking/Air Intakes/ Loading Docks	Proportional	—	0-10V 4-20 mA	0-2000	700	50

**LEGEND**

ppm — Parts Per Million

**Operating Sequence**

**COOLING, UNITS WITHOUT ECONOMIZER** — When the thermostat calls for one stage of cooling, Y1 and G are energized. The indoor-fan contactor (IFC) and compressor contactor(s) (C.A1 and C.B1 on three-compressor units or C.A1 only on two-compressor units), and outdoor-fan contactors (OFC1 and OFC2 when outdoor temperature is above LTS setting) are energized and the indoor-fan motor, compressor(s) (A1 and B1 on three compressor units or A1 only on two-compressor units), and outdoor fans controlled by OFC1 are started. If the outdoor temperature is above the setting of the low temperature switch, the outdoor fans controlled by OFC2 are also started.

If more cooling is required, the thermostat will call for a second stage of cooling, energizing Y2. This will allow relay CRI to energize, which in turn energizes the compressor contactor (C.C1 on three-compressor units or C.B1 on two-compressor units). The second stage compressor (C1 on three-compressor units or B1 on two-compressor units) is then started.

**HEATING, UNITS WITHOUT ECONOMIZER**

NOTE: The 48HJ020-028 units have 2 stages of heat.

When the thermostat calls for heating, power is sent to W on the IGC (integrated gas unit controller) board. An LED (light-emitting diode) on the IGC board will be on during normal operation. A check is made to ensure that the rollout switch and limit switch are closed and the induced-draft motor is running. The induced-draft motor is then energized, and when speed is proven with the hall effect sensor on the motor, the ignition activation period begins. The burners will ignite within 5 seconds.

If the burners do not light, there is a 22-second delay before another 5-second attempt. If the burners still do not light, this sequence is repeated for 15 minutes. After the 15 minutes have elapsed, if the burners still have not lit, heating is locked out. To reset the control, break 24-v power to the thermostat.

When ignition occurs the IGC board will continue to monitor the condition of the rollout and limit switches, the hall effect sensor, as well as the flame sensor. If the unit is controlled through a room thermostat set for fan auto., 45 seconds after ignition occurs, the indoor-fan motor will be energized (and the outdoor-air dampers will open to their minimum position). If for some reason the overtemperature limit opens prior to the start of the indoor fan blower, on the next attempt, the

45-second delay will be shortened to 5 seconds less than the time from initiation of heat to when the limit tripped. Gas will not be interrupted to the burners and heating will continue. Once modified, the fan on delay will not change back to 45 seconds unless power is reset to the control.

When additional heat is required, W2 closes and initiates power to the second stage of the main gas valve. When the thermostat is satisfied, W1 and W2 open and the gas valve closes, interrupting the flow of gas to the main burners. If the call for W1 lasted less than 1 minute, the heating cycle will not terminate until 1 minute after W1 became active. If the unit is controlled through a room thermostat set for fan auto., the indoor-fan motor will continue to operate for an additional 45 seconds then stop (and the outdoor-air dampers will close). If the overtemperature limit opens after the indoor motor is stopped within 10 minutes of W1 becoming inactive, on the next cycle the time will be extended by 15 seconds. The maximum delay is 3 minutes. Once modified, the fan off delay will not change back to 45 seconds unless power is reset to the control.

A LED indicator is provided on the IGC to monitor operation. The IGC is located by removing the side panel and viewing the IGC through the view port located in the control box access panel. During normal operation, the LED is continuously on. For information on troubleshooting refer to page 56.

**COOLING, UNITS WITH ECONOMIZER IV** — When free cooling is not available, the compressors will be controlled by the zone thermostat. When free cooling is available, the outdoor-air damper is modulated by the EconoMiSer IV control to provide a 50 to 55 F supply-air temperature into the zone. As the supply-air temperature fluctuates above 55 or below 50 F, the dampers will be modulated (open or close) to bring the supply-air temperature back within the set point limits.

For EconoMiSer IV operation, there must be a thermostat call for the fan (G). This will move the damper to its minimum position during the occupied mode.

Above 50 F supply-air temperature, the dampers will modulate from 100% open to the minimum open position. From 50 F to 45 F supply-air temperature, the dampers will maintain at the minimum open position. Below 45 F the dampers will be completely shut. As the supply-air temperature rises, the dampers will come back open to the minimum open position once the supply air temperature rises to 48 F.

If optional power exhaust is installed, as the outdoor-air damper opens and closes, the power exhaust fans will be energized and deenergized.

If field-installed accessory CO<sub>2</sub> sensors are connected to the EconoMi\$er IV control, a demand controlled ventilation strategy will begin to operate. As the CO<sub>2</sub> level in the zone increases above the CO<sub>2</sub> set point, the minimum position of the damper will be increased proportionally. As the CO<sub>2</sub> level decreases because of the increase in fresh air, the outdoor-air damper will be proportionally closed. Damper position will follow the higher demand condition from DCV mode or free cooling mode.

Damper movement from full closed to full open (or vice versa) will take between 1½ and 2½ minutes.

If free cooling can be used as determined from the appropriate changeover command (switch, dry bulb, enthalpy curve, differential dry bulb, or differential enthalpy), a call for cooling (Y1 closes at the thermostat) will cause the control to modulate the dampers open to maintain the supply air temperature set point at 50 to 55 F.

As the supply-air temperature drops below the set point range of 50 to 55 F, the control will modulate the outdoor-air dampers closed to maintain the proper supply-air temperature.

**HEATING, UNITS WITH ECONOMISER IV** — When the room temperature calls for heat, the heating controls are energized as described in the Heating, Units Without Economizer section. The IFM (indoor fan motor) is energized and the EconoMi\$er IV damper modulates to the minimum position. When the thermostat is satisfied and W1 and W2 are deenergized, the IFM continues to run, and the economizer damper modulates to the minimum position.

## SERVICE

### ▲ WARNING

Before performing service or maintenance operations on unit, turn off main power switch to unit. Electrical shock could cause personal injury.

**Cleaning** — Inspect unit interior at beginning of each heating and cooling season and as operating conditions require. Remove unit top panel and/or side panels for access to unit interior.

**EVAPORATOR COIL** — Clean as required with commercial coil cleaner.

**CONDENSER COIL** — Clean condenser coil annually and as required by location and outdoor-air conditions. Inspect coil monthly; clean as required.

**CONDENSATE DRAIN** — Check and clean each year at the start of the cooling season. In winter, keep drains and traps dry. An access panel is located above the condensate connection to allow easy clean out of the condensate pan. The first time the panel is removed, the insulation behind the access panel will need to be cut away. Carefully cut the insulation with a knife or blade on three sides so the insulation can be folded out of the way during cleaning. Be careful not to damage components behind the insulation while cutting. Once cleaning is completed, fold the insulation back into place and secure the access panel in the original position.

**FILTERS** — Clean or replace at start of each heating and cooling season, or more often if operating conditions require. Refer to Table 1 for type and size.

**OUTDOOR-AIR INLET SCREENS** — Clean screens with steam or hot water and a mild detergent. Do not use throwaway filters in place of screens. See Table 1 for quantity and size.

**MAIN BURNER** — At the beginning of each heating season, inspect for deterioration or blockage due to corrosion or other causes. Observe the main burner flames. Refer to Main Burners section on page 48.

**FLUE GAS PASSAGEWAYS** — The flue collector box and heat exchanger cells may be inspected by removing heat section access panel (Fig. 4), flue box cover, and main burner assembly (Fig. 30). Refer to Main Burners section on page 48 for burner removal sequence. If cleaning is required, clean tubes with a wire brush.

Use caution with ceramic heat exchanger baffles. When installing retaining clip, be sure the center leg of the clip extends inward toward baffle. See Fig. 31.

**COMBUSTION-AIR BLOWER** — Clean periodically to assure proper airflow and heating efficiency. Inspect blower wheel every fall and periodically during heating season. For the first heating season, inspect blower wheel bi-monthly to determine proper cleaning frequency.

To inspect blower wheel, remove heat section panel. Using an inspection mirror and flashlight, look into the flue exhaust duct to inspect the wheel. If cleaning is required, remove motor and wheel assembly by removing the screws holding the flue box cover to the flue box. See Fig. 30. Remove the screws holding the inducer housing to the inlet plate. The wheel can then be removed from the motor shaft and cleaned with a detergent or solvent. Replace the wheel onto the motor shaft in the correct position and reassemble the flue cover onto the flue box.

## Lubrication

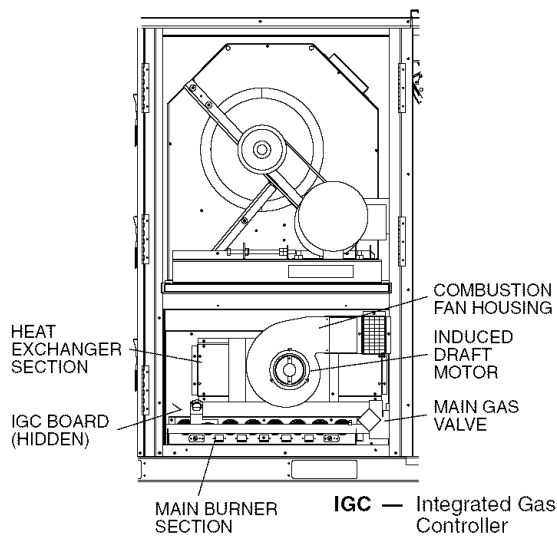
**COMPRESSORS** — Each compressor is charged with the correct amount of oil at the factory. Conventional white oil (Zerol 150T or Sontex SA32) is used. White oil is compatible with 3GS oil, and 3GS oil may be used if the addition of oil is required. See compressor nameplate for original oil charge. Oil recharge amount is shown in Table 1. When a compressor is exchanged in the field it is possible that a major portion of the oil from the replaced compressor may still be in the system. While this will not affect the reliability of the replacement compressor, the extra oil will add rotor drag and increase power usage. To remove this excess oil, an access valve may be added to the lower portion of the suction line at the inlet of the compressor. The compressor should then be run for 10 minutes, shut down and the access valve opened until no oil flows. This should be repeated twice to make sure the proper oil level has been achieved.

**FAN SHAFT BEARINGS** — Lubricate bearings at least every 6 months with suitable bearing grease. Typical lubricants are given below:

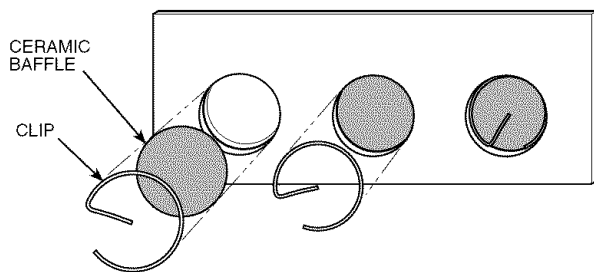
MANUFACTURER	LUBRICANT
Texaco	Regal AFB-2*
Mobil	Mobilplex EP No. 1
Sunoco	Prestige 42
Texaco	Multifak 2

\*Preferred lubricant because it contains rust and oxidation inhibitors.

**CONDENSER AND EVAPORATOR-FAN MOTOR BEARINGS** — The condenser and evaporator-fan motors have permanently sealed bearings, so no field lubrication is necessary.



**Fig. 30 — Typical Gas Heating Section**



NOTE: One baffle and clip will be in each upper tube of the heat exchanger.

**Fig. 31 — Removing Heat Exchanger Ceramic Baffles and Clips**

**Evaporator Fan Service and Replacement** — The 48HJ units feature a slide-out fan deck for easy servicing of the indoor-fan motor, pulleys, belt, and bearings. To service components in this section, perform the following procedure:

1. Turn off unit power.
2. Open the fan section access panel.
3. Remove three no. 10 screws at front of slide-out fan deck. Save screws. See Fig. 32.
4. Disconnect the electrical plugs and wires connected to the slide-out fan deck (evaporator fan plug, supply air thermostat, and fan status switch if installed). Wires may be damaged if not disconnected.
5. Fan deck can now be slid out to access serviceable components.

**⚠ CAUTION**

DO NOT SLIDE FAN DECK OUT PAST THE STOP BRACKET. If further access is required, the fan deck must be supported. Make sure plugs and wiring are not pinched between fan housing and unit center post. Damage to unit may result.

6. To replace fan deck to operating position, slide fan deck back into the unit. Secure with the three no. 10 screws removed in Step 3.
7. Re-attach electrical plugs and wires.
8. Close fan section access door.
9. Restore power to unit.

**Evaporator Fan Performance Adjustment (Fig. 32 and 33)** — Fan motor pulleys are factory set for speed shown in Table 1.

To change fan speeds:

1. Shut off unit power supply.
2. Loosen nuts on the 4 carriage bolts in the mounting base. Using adjusting bolts and plate, slide motor and remove belt.
3. Loosen movable-pulley flange setscrew (see Fig. 33).
4. Screw movable flange toward fixed flange to increase speed and away from fixed flange to decrease speed. Increasing fan speed increases load on motor. Do not exceed maximum speed specified in Table 1.

See Table 24 for air quantity limits.

5. Set movable flange at nearest keyway of pulley hub and tighten setscrew. (See Table 1 for speed change for each full turn of pulley flange.)
6. Replace and tighten belts (see Belt Tension Adjustment section below).
7. Restore power to unit.

To align fan and motor pulleys:

1. Loosen fan pulley setscrews.
2. Slide fan pulley along fan shaft.
3. Make angular alignment by loosening motor from mounting plate.

**Belt Tension Adjustment** — To adjust belt tension:

1. Turn off unit power.
2. Slide out fan deck to service position as shown in Evaporator Fan Service and Replacement section above.
3. Loosen fan motor bolts.
4. Move motor mounting plate to adjust to proper belt tension. See Table 30. Motor adjuster bolts may be used to tighten belts. See Fig. 32.
5. Check for proper belt alignment. Adjust if necessary.
6. Tighten motor mounting plate bolts to lock motor in proper position.
7. Return fan deck back into operating position.
8. Restore power to unit.

**Table 30 — Belt Tension Adjustment**

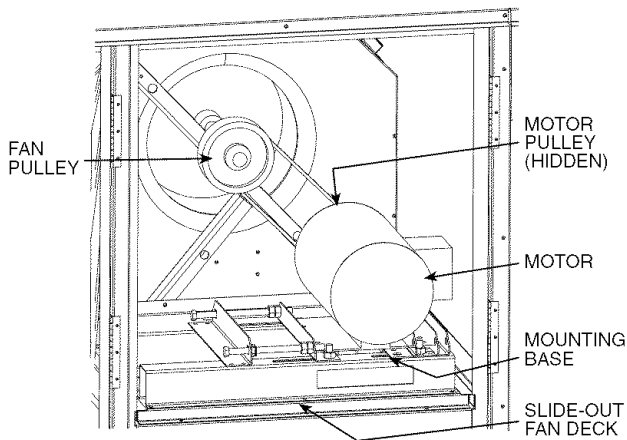
48HJ	VOLTAGE	BELT TENSION (lb)							
		Unit Model Number Position 10							
		A,J	B,K	C,L	D,M	E,N	F,P	G,Q	H,R
020	208/230	N/A	4.9	5.1	5.7	N/A	4.7	5.0	5.5
	460	N/A	4.9	5.1	5.7	N/A	4.7	5.0	5.5
	575	N/A	3.9	5.2	5.7	N/A	3.8	4.7	5.5
024	208/230	4.8	5.1	5.6	4.5	N/A	4.7	5.0	5.5
	460	4.8	5.1	5.6	4.5	N/A	4.7	5.0	5.5
	575	5.3	5.1	5.6	4.5	N/A	5.2	5.0	5.5
028	208/230	4.5	5.4	5.9	4.5	4.5	5.4	5.9	4.5
	460	4.5	5.4	5.9	4.5	4.5	5.4	5.9	4.5
	575	4.5	5.4	5.9	4.5	4.5	5.4	5.9	4.5

LEGEND

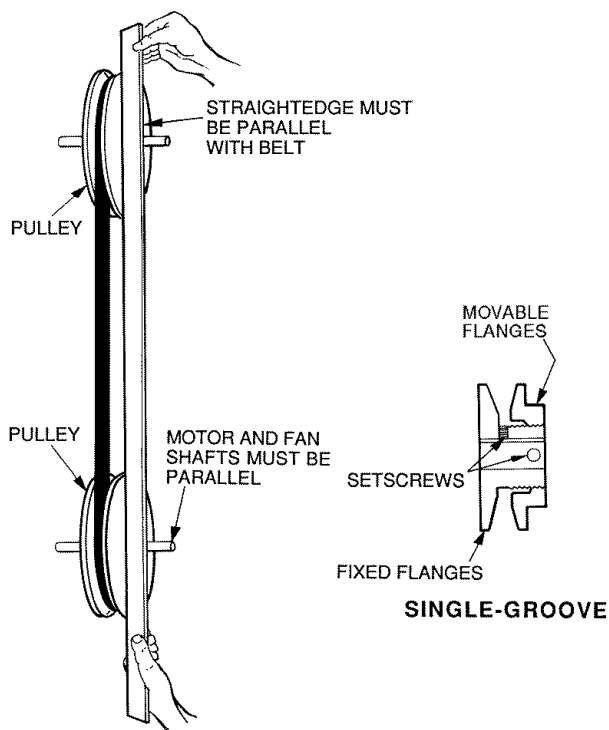
N/A — Not Available

**Condenser-Fan Adjustment (Fig. 34)**

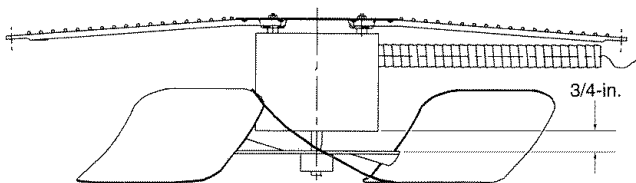
1. Shut off unit power supply.
2. Remove condenser-fan assembly (grille, motor, motor cover, and fan) and loosen fan hub setscrews.
3. Adjust fan height as shown in Fig. 34.
4. Tighten setscrews and replace condenser-fan assembly.
5. Turn on power to unit.



**Fig. 32 — Evaporator-Fan Motor Adjustment**



**Fig. 33 — Evaporator-Fan Alignment and Adjustment**



**Fig. 34 — Condenser-Fan Adjustment**

**Power Failure** — Dampers have a spring return. In event of power failure, dampers will return to fully closed position until power is restored. *Do not manually operate damper motor.*

**Refrigerant Charge** — Amount of refrigerant charge is listed on unit nameplate and in Table 1. Refer to Carrier GTAC II; Module 5; Charging, Recovery, Recycling, and Reclamation section for charging methods and procedures. Unit panels must be in place when unit is operating during charging procedure.

NOTE: Do not use recycled refrigerant as it may contain contaminants.

**NO CHARGE** — Use standard evacuating techniques. After evacuating system, weigh in the specified amount of refrigerant (refer to Table 1).

**LOW CHARGE COOLING** — Using cooling charging chart (see Fig. 35-37), add or remove refrigerant until conditions of the chart are met. An accurate pressure gage and temperature-sensing device is required. Charging is accomplished by ensuring the proper amount of liquid subcooling. Measure liquid line pressure at the liquid line service valve using pressure gage. Connect temperature sensing device to the liquid line near the liquid line service valve and insulate it so that outdoor ambient temperature does not affect reading.

**TO USE THE COOLING CHARGING CHART** — Use the above temperature and pressure readings, and find the intersection point on the cooling charging chart. If intersection point on chart is above line, add refrigerant. If intersection point on chart is below line, carefully recover some of the charge. Recheck suction pressure as charge is adjusted.

NOTE: Indoor-air cfm must be within normal operating range of unit. All outdoor fans must be operating.

The TXV (thermostatic expansion valve) is set to maintain between 10 and 15 degrees of superheat at the compressors. The valves are factory set and should not require re-adjustment.

### Gas Valve Adjustment

**NATURAL GAS** — The gas valve opens and closes in response to the thermostat or limit control.

When power is supplied to valve terminals W2 (High Fire) and C1, the main valve opens to its preset position.

The regular factory setting is stamped on the valve body. The setting is 3.00 in. wg for vertical supply/discharge units. The setting is 2.95 in. wg for horizontal supply/discharge units.

To adjust regulator:

1. Set unit at setting for no call for heat.
2. Turn main gas valve to OFF position.
3. Remove 1/8-in. pipe plug from manifold or gas valve pressure tap connection. Install a suitable pressure-measuring device.
4. Set main gas valve to ON position.
5. Set thermostat at setting to call for heat.
6. Remove screw cap covering regulator adjustment screw (See Fig. 38).
7. Turn adjustment screw clockwise to increase pressure or counterclockwise to decrease pressure.
8. Once desired pressure is established, set unit setting for no call for heat, turn off main gas valve, remove pressure-measuring device, and replace 1/8-in. pipe plug and screw cap.

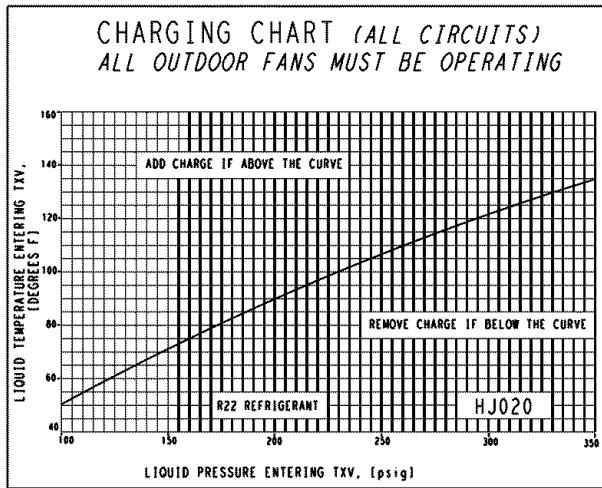
**Main Burners** — For most applications, main burners are factory set and should require no adjustment.

For applications at altitudes above 2000 ft, refer to Tables 31 and 32 for altitude compensation.

### MAIN BURNER REMOVAL

1. Shut off (field-supplied) manual main gas valve.
2. Shut off power to unit.
3. Remove gas section access panel.
4. Disconnect gas piping from gas valve inlet.
5. Remove wires from gas valve.
6. Remove wires from rollout switch.
7. Remove sensor wire and ignitor cable from IGC board.
8. Remove 2 screws securing manifold bracket to basepan.
9. Remove 2 screws that hold the burner assembly to vestibule plate.
10. Lift burner/manifold assembly out of unit.

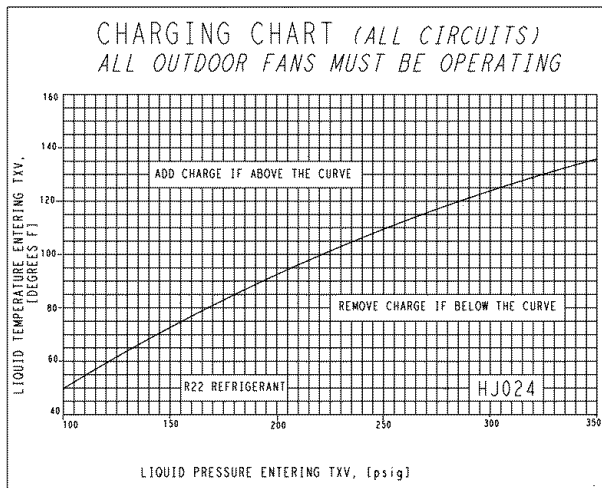




LEGEND

TXV — Thermostatic Expansion Valve

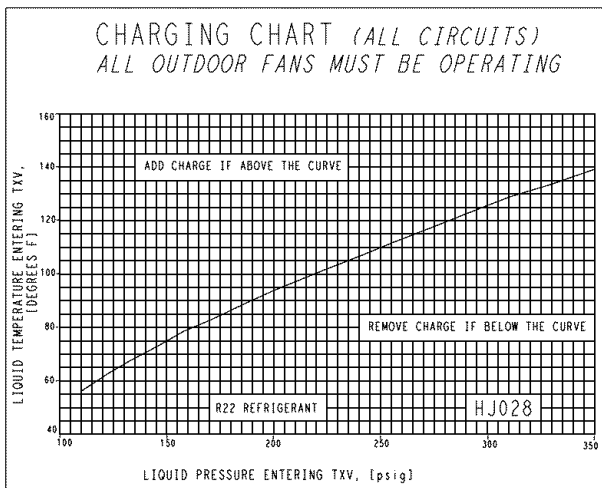
Fig. 35 — Cooling Charging Chart — 48HJ020 Units



LEGEND

TXV — Thermostatic Expansion Valve

Fig. 36 — Cooling Charging Chart — 48HJ024 Units



LEGEND

TXV — Thermostatic Expansion Valve

Fig. 37 — Cooling Charging Chart — 48HJ028 Units

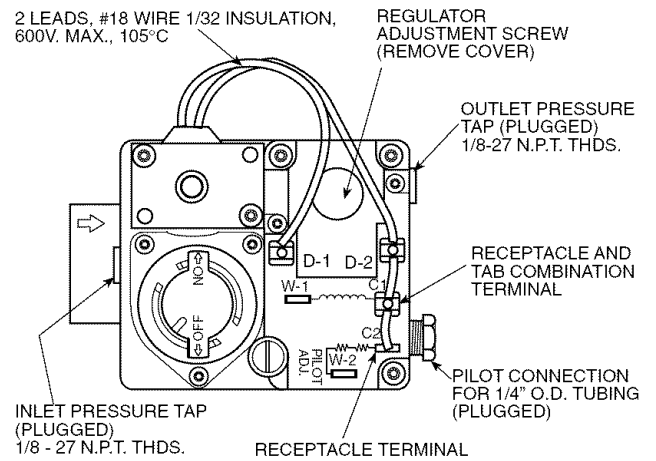


Fig. 38 — Gas Valve

Table 31 — Altitude Compensation (Natural Gas)

ELEVATION (ft)	ORIFICE SIZE — NATURAL GAS			
	Low Heat	Medium Heat	High Heat (6 Cell)	High Heat (8 Cell)
0-2,000	29	30	29	29
2,000	29	30	29	29
3,000	30	31	30	30
4,000	30	31	30	30
5,000	30	31	30	30
6,000	30	31	30	30
7,000	31	32	31	31
8,000	31	32	31	31
9,000	31	32	31	31
above 10,000	32	33	32	32

Table 32 — Altitude Compensation (LP Gas)

ELEVATION (ft)	ORIFICE SIZE — LP GAS			
	Low Heat	Medium Heat	High Heat (6 Cell)	High Heat (8 Cell)
0-2,000	35	38	35	35
2,000	36	39	36	36
3,000	36	39	36	36
4,000	37	40	37	37
5,000	37	40	37	37
6,000	38	41	38	38
7,000	39	42	39	39
8,000	40	43	40	40
9,000	41	44	41	41
above 10,000	42	45	42	42

CLEANING AND ADJUSTMENT

1. Remove burner rack from unit as described in Main Burner Removal section above.
2. Inspect burners, and if dirty, remove burners from rack.
3. Using a soft brush, clean burners and crossover port as required.
4. Adjust spark gap. See Fig. 39.
5. Reinstall burners on rack.
6. Reinstall burner rack as described above.

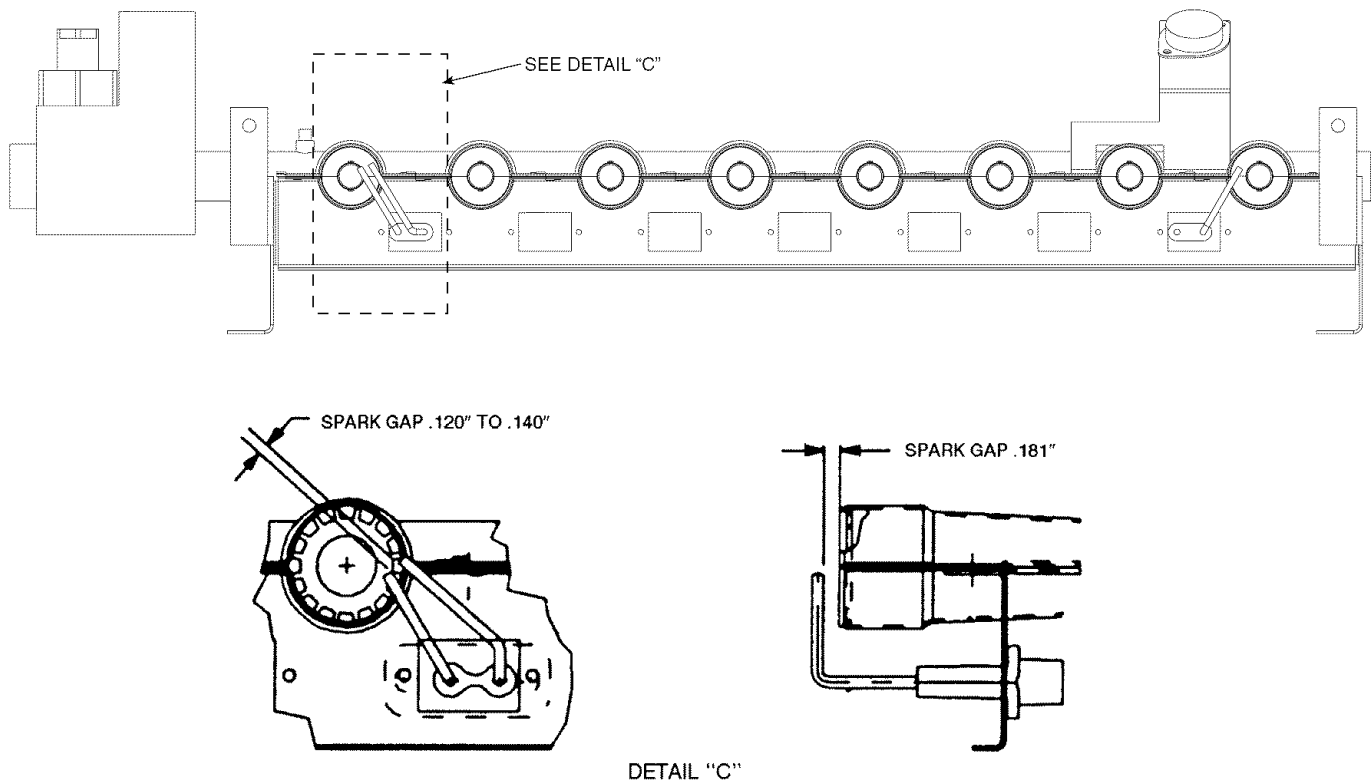


Fig. 39 — Spark Gap Adjustment

**Filter Drier** — Replace whenever refrigerant system is exposed to atmosphere.

### Protective Devices

#### COMPRESSOR PROTECTION

**Overcurrent** — Each compressor has internal line break motor protection.

**Overtemperature** — Each compressor has an internal protector to protect it against excessively high discharge gas temperatures.

**Compressor Lockout** — If any of the safeties (high-pressure, low-pressure, freeze protection thermostat, compressor internal thermostat) trip, or if there is loss of power to the compressors, the cooling lockout (CLO) will lock the compressors off. To reset, manually move the thermostat setting.

**HIGH-PRESSURE AND LOW-PRESSURE SWITCHES** — If either switch trips, or if the compressor overtemperature switch activates, that refrigerant circuit will be automatically locked out by the CLO. To reset, manually move the thermostat setting.

**FREEZE PROTECTION THERMOSTAT (FPT)** — An FPT is located on the top and bottom of the evaporator coil. They detect frost build-up and turn off the compressor, allowing the coil to clear. Once the frost has melted, the compressor can be reenergized by resetting the compressor lockout.

**EVAPORATOR FAN MOTOR PROTECTION** — A manual reset, calibrated trip, magnetic circuit breaker protects against overcurrent. Do not bypass connections or increase the size of the breaker to correct trouble. Determine the cause and correct it before resetting the breaker.

**CONDENSER-FAN MOTOR PROTECTION** — Each condenser-fan motor is internally protected against overtemperature.

Fuses are also located in the control box and feed power to the condenser fan motors. Always replace blown fuses with the correct size fuse as indicated on the unit fuse label.

**Relief Devices** — All units have relief devices to protect against damage from excessive pressures (i.e., fire). These devices protect the high and low side.

**Control Circuit, 24-V** — Each control circuit is protected against overcurrent by a 3.2 amp circuit breaker. Breaker can be reset. If it trips, determine cause of trouble before resetting. See Fig. 40-42 for wiring.

**Replacement Parts** — A complete list of replacement parts may be obtained from any Carrier distributor upon request.

**Diagnostic LEDs** — The IGC control board has a LED for diagnostic purposes. The IGC error codes are shown in Table 33.

Table 33 — IGC LED Indications

ERROR CODE	LED INDICATION
Normal Operation	On
Hardware Failure	Off
Fan On/Off Delay Modified	1 Flash
Limit Switch Fault	2 Flashes
Flame Sense Fault	3 Flashes
Five Consecutive Limit Switch Faults	4 Flashes
Ignition Lockout Fault	5 Flashes
Inducer Switch Fault	6 Flashes
Rollout Switch Fault	7 Flashes
Internal Control Fault	8 Flashes
Software Lockout	9 Flashes

#### LEGEND












IGC — Integrated Gas Unit Controller  
LED — Light-Emitting Diode

#### NOTES:

1. There is a 3-second pause between error code displays.
2. If more than one error code exists, all applicable error codes will be displayed in numerical sequence.
3. Error codes on the IGC will be lost if power to the unit is interrupted.

## LEGEND

**Fig. 40 — Low Voltage Control Schematic**  
**Fig. 41 — Power Schematic and Fig. 42 — Component Arrangement**

<p><b>__A</b> — Circuit A</p> <p><b>AHA</b> — Adjustable Heat Anticipator</p> <p><b>AL</b> — Ambient Limit</p> <p><b>AUX</b> — Auxiliary Contact</p> <p><b>__B</b> — Circuit B</p> <p><b>__C</b> — Circuit C</p> <p><b>C</b> — Compressor, Contactor</p> <p><b>CAP</b> — Capacitor</p> <p><b>CB</b> — Circuit Breaker</p> <p><b>CC</b> — Compressor Contactor</p> <p><b>CCH</b> — Crankcase Heater</p> <p><b>CLO</b> — Compressor Lockout</p> <p><b>COMP</b> — Compressor</p> <p><b>CR</b> — Compressor Relay</p> <p><b>CS</b> — Current Sensor</p> <p><b>DU</b> — Dummy Terminal</p> <p><b>FCS</b> — Fan Cycling Switch</p> <p><b>FIOP</b> — Factory-Installed Option</p> <p><b>FPT</b> — Female Pipe Thread</p> <p><b>FS</b> — Flame Sensor</p> <p><b>FU</b> — Fuse</p> <p><b>GND</b> — Ground</p> <p><b>GV</b> — Gas Valve</p> <p><b>GVR</b> — Gas Valve Relay</p> <p><b>HACR</b> — Heating, Air Conditioning, and Refrigeration</p> <p><b>HS</b> — Heat Sensor</p> <p><b>HERM</b> — Hermetic</p> <p><b>HPS</b> — High-Pressure Switch</p> <p><b>I</b> — Ignitor</p> <p><b>IA</b> — Indoor Air</p> <p><b>IAQ</b> — Indoor-Air Quality</p> <p><b>IDM</b> — Induced-Draft Motor</p> <p><b>IFC</b> — Indoor-Fan Contactor</p> <p><b>IFCB</b> — Indoor-Fan Circuit Breaker</p> <p><b>IFM</b> — Indoor-Fan Motor</p> <p><b>IGC</b> — Integrated Gas Controller</p> <p><b>IRH</b> — Indoor Relative Humidity</p> <p><b>LAFC</b> — Low Ambient Fan Control</p>	<p><b>LPS</b> — Low Pressure Switch</p> <p><b>LS</b> — Limit Switch</p> <p><b>MGV</b> — Main Gas Valve</p> <p><b>OA</b> — Outdoor Air</p> <p><b>OAS</b> — Outdoor Air Sensor</p> <p><b>OAT</b> — Outdoor-Air Temperature</p> <p><b>OFC</b> — Outdoor-Fan Contactor</p> <p><b>OFM</b> — Outdoor-Fan Motor</p> <p><b>ORH</b> — Outdoor Relative Humidity</p> <p><b>PEC</b> — Power Exhaust Contactor</p> <p><b>PEM</b> — Power Exhaust Motor</p> <p><b>PL</b> — Plug</p> <p><b>QC</b> — Quadruple Contactor</p> <p><b>QT</b> — Quadruple Terminal</p> <p><b>RAS</b> — Return Air Sensor</p> <p><b>RAT</b> — Return Air Thermostat</p> <p><b>RS</b> — Rollout Switch</p> <p><b>SAT</b> — Supply-Air Temperature</p> <p><b>TB</b> — Terminal Block</p> <p><b>TC</b> — Thermostat Cooling</p> <p><b>TH</b> — Thermostat Heating</p> <p><b>TRAN</b> — Transformer</p> <p> Terminal (Marked)</p> <p> Terminal (Unmarked)</p> <p> Terminal Block</p> <p> Splice</p> <p> Splice (Marked)</p> <p> Splice (Field Supplied)</p> <p> Factory Wiring</p> <p> Field Control Wiring</p> <p> Field Power Wiring</p> <p> Accessory or Optional Wiring</p> <p> To Indicate Common Potential Only, Not To Represent Wiring</p>
------------------------------------------------------------------------------------------------------------------------------------------------------------------------------------------------------------------------------------------------------------------------------------------------------------------------------------------------------------------------------------------------------------------------------------------------------------------------------------------------------------------------------------------------------------------------------------------------------------------------------------------------------------------------------------------------------------------------------------------------------------------------------------------------------------------------------------------------------------------------------------------------------------------------------------------------------------------------------------------------------------------------------------------------------------------------------------------------------------------------------------------------------------------------------------------------------------------------------------------------------------------------------------------------------------------------------------------------------------------------------------------------------------------------------------------------------------	------------------------------------------------------------------------------------------------------------------------------------------------------------------------------------------------------------------------------------------------------------------------------------------------------------------------------------------------------------------------------------------------------------------------------------------------------------------------------------------------------------------------------------------------------------------------------------------------------------------------------------------------------------------------------------------------------------------------------------------------------------------------------------------------------------------------------------------------------------------------------------------------------------------------------------------------------------------------------------------------------------------------------------------------------------------------------------------------------------------------------------------------------------------------------------------------------------------------------------------------------------------------------------------------------------------------------------------------------------------------------------------------------------------------------------------------------------------------------------------------------------------------------------------------------------------------------------------------------------------------------------------------------------------------------------------------------------------------------------------------------------------------------------------------------------------------------------------------------------------------------------------------------------------------------------------------------------------------------------------------------------------------------------------------------------------------------------------------------------------------------------------

### THERMOSTAT/IGC MARKINGS

<p><b>BM</b> — Blower Motor</p> <p><b>C</b> — Common</p> <p><b>CM</b> — Inducer Motor</p> <p><b>CS</b> — Centrifugal Switch</p> <p><b>G</b> — Fan</p> <p><b>GV</b> — Gas Valve</p> <p><b>IFO</b> — Indoor Fan On</p> <p><b>LI</b> — Line I</p> <p><b>R</b> — Thermostat Power</p>	<p><b>RS</b> — Rollout Switch</p> <p><b>RT</b> — Power Supply</p> <p><b>SS</b> — Speed Sensor</p> <p><b>W</b> — Thermostat Heat</p> <p><b>W1</b> — 1st Stage of Heating</p> <p><b>W2</b> — 2nd Stage of Heating</p> <p><b>X</b> — Alarm Output</p> <p><b>Y1</b> — 1st Stage of Cooling</p> <p><b>Y2</b> — 2nd Stage of Cooling</p>
-----------------------------------------------------------------------------------------------------------------------------------------------------------------------------------------------------------------------------------------------------------------------------------	------------------------------------------------------------------------------------------------------------------------------------------------------------------------------------------------------------------------------------------------------------------------------------------------------------------------------------

#### NOTES:

1. Factory wiring is in accordance with the National Electrical Codes. Any field modifications or additions must be in compliance with all applicable codes.
2. Use 75 C minimum wire for field power supply. Use copper wires for all units.
3. All circuit breakers "Must Trip Amps" are equal to or less than 156% RLA (rated load amps).
4. Compressor and fan motors are thermally protected. Three-phase motors protected against primary single phase conditions.
5. The CLO locks out the compressor to prevent short cycling on compressor overload and safety devices; before replacing CLO, check these devices.

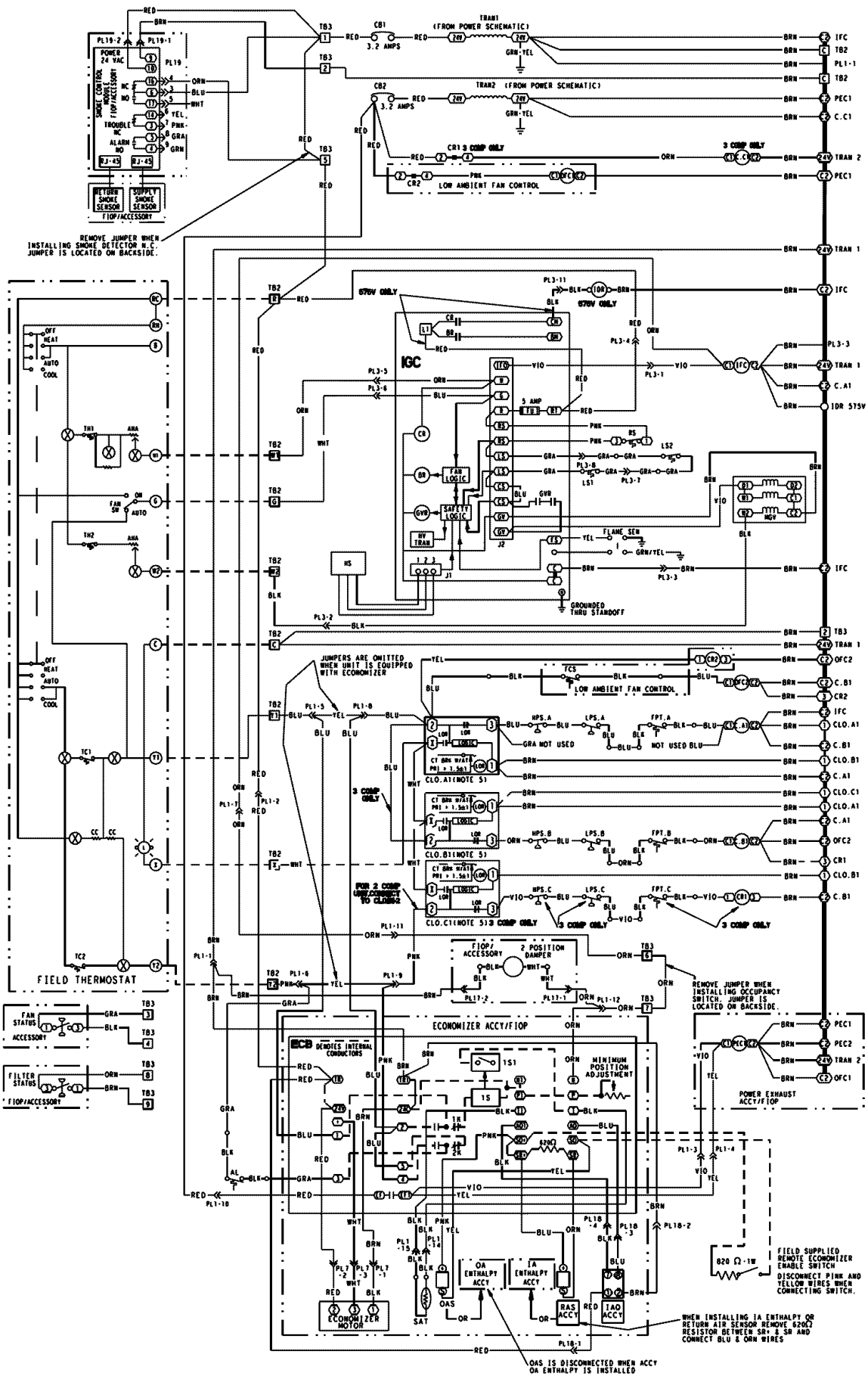


Fig. 40 — Low Voltage Control Schematic

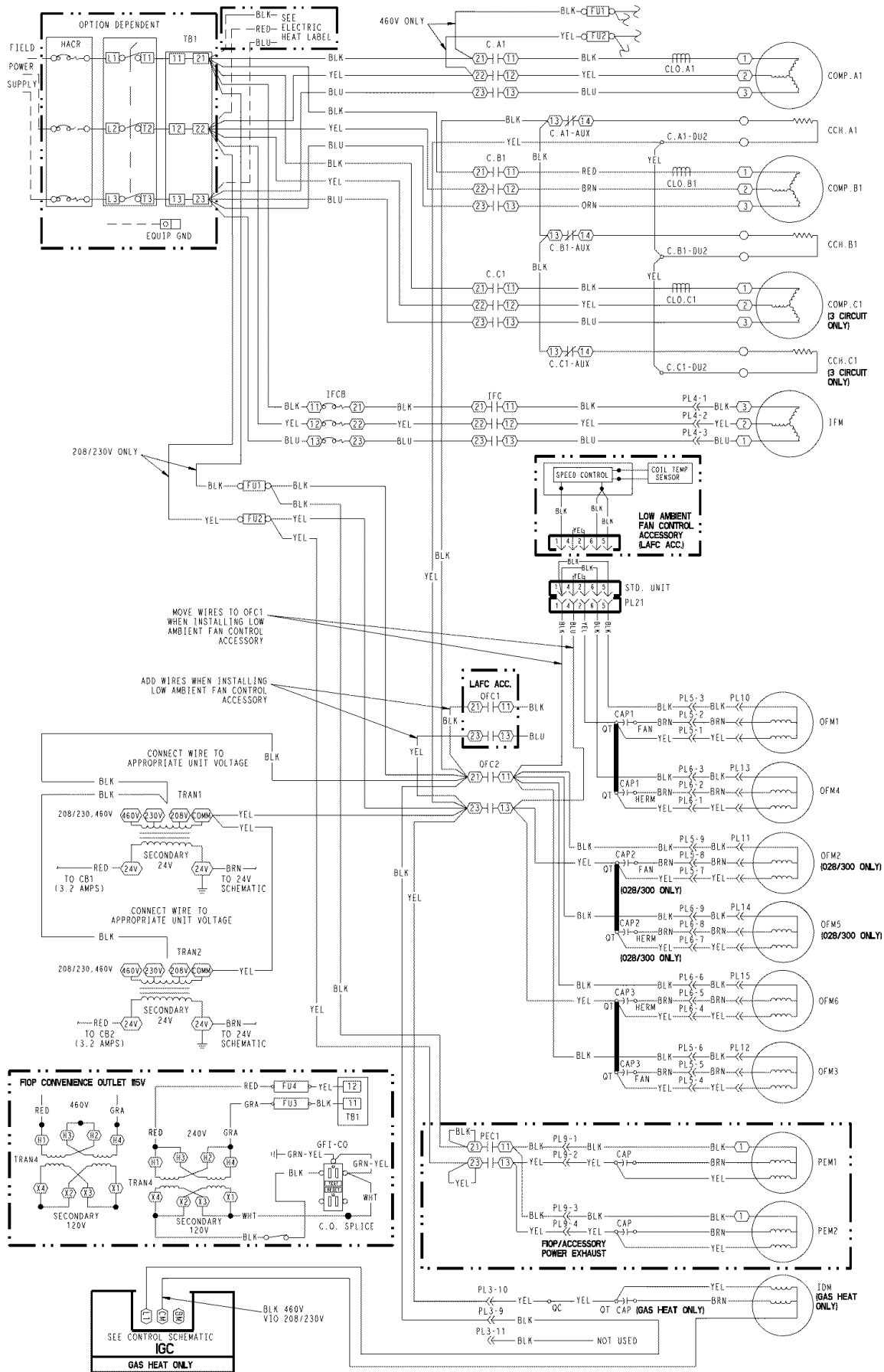
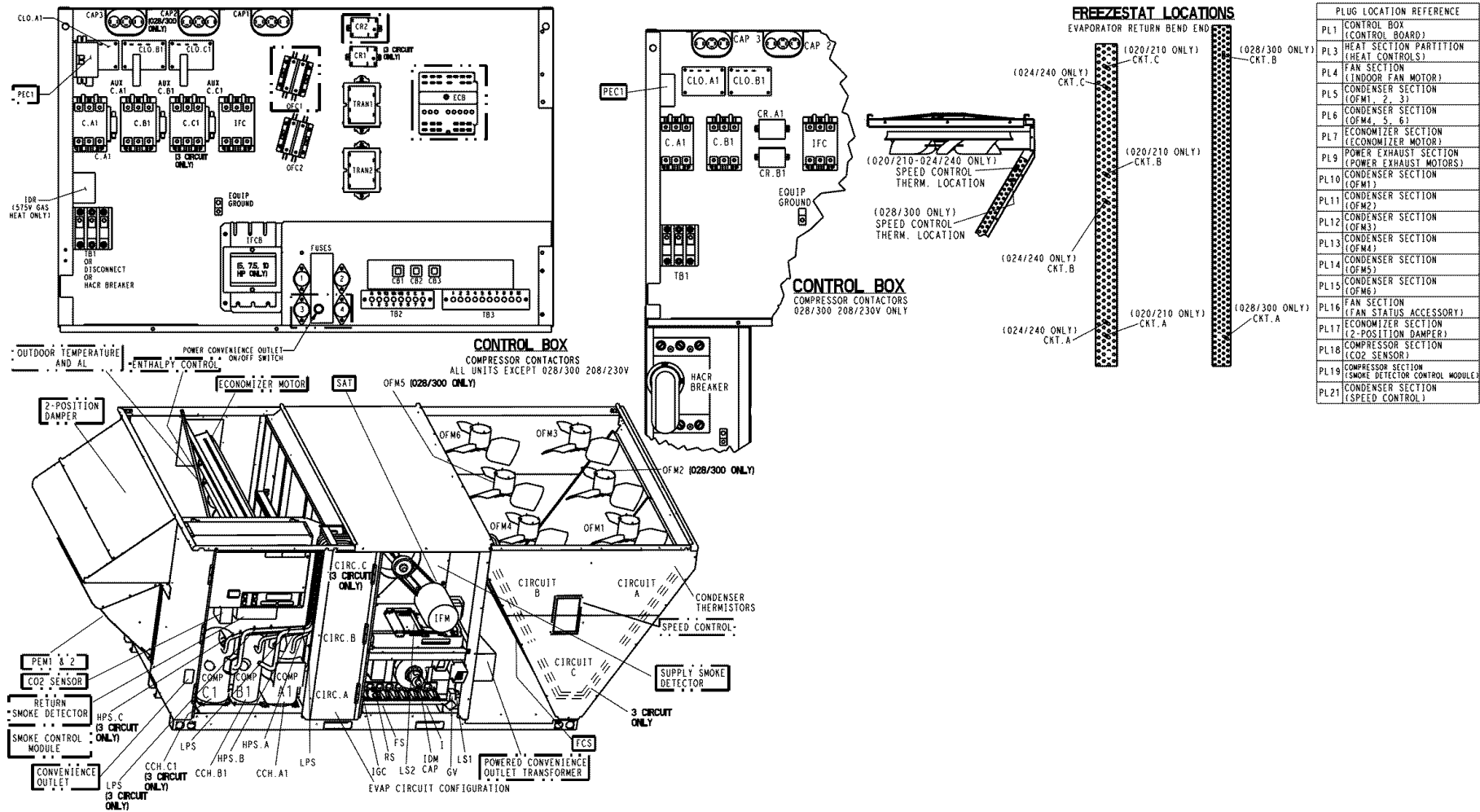


Fig. 41 — Power Schematic



PLUG LOCATION REFERENCE	COMPONENT
PL1	CONTROL BOX (CONTROL BOARD)
PL3	HEAT SECTION PARTITION (HEAT CONTROLS)
PL4	FAN SECTION (INDOOR FAN MOTOR)
PL5	CONDENSER SECTION (OFM1, 2, 3)
PL6	CONDENSER SECTION (OFM4, 5, 6)
PL7	ECONOMIZER SECTION (ECONOMIZER MOTOR)
PL9	POWER EXHAUST SECTION (POWER EXHAUST MOTORS)
PL10	CONDENSER SECTION (OFM1)
PL11	CONDENSER SECTION (OFM2)
PL12	CONDENSER SECTION (OFM3)
PL13	CONDENSER SECTION (OFM4)
PL14	CONDENSER SECTION (OFM5)
PL15	CONDENSER SECTION (OFM6)
PL16	FAN SECTION (FAN STATUS ACCESSORY)
PL17	ECONOMIZER SECTION (2-POSITION DAMPER)
PL18	COMPRESSOR SECTION (CO2 SENSOR)
PL19	COMPRESSOR SECTION (SMOKE DETECTOR CONTROL MODULE)
PL27	CONDENSER SECTION (SPEED CONTROL)

Fig. 42 — Component Arrangement

## TROUBLESHOOTING

**Unit Troubleshooting** — Refer to Tables 34-36 and Fig. 43.

**Table 34 — Cooling Service Analysis**

PROBLEM	CAUSE	REMEDY
<b>Compressor and Condenser Fan Will Not Start.</b>	Power failure.	Call power company.
	Fuse blown or circuit breaker tripped.	Replace fuse or reset circuit breaker.
	Defective thermostat, contactor, transformer, or control relay.	Replace component.
	Insufficient line voltage.	Determine cause and correct.
	Incorrect or faulty wiring.	Check wiring diagram and rewire correctly.
	Thermostat setting too high.	Lower thermostat setting below room temperature.
<b>Compressor Will Not Start but Condenser Fan Runs.</b>	Faulty wiring or loose connections in compressor circuit.	Check wiring and repair or replace.
	Compressor motor burned out, seized, or internal overload open.	Determine cause. Replace compressor.
	Defective overload.	Determine cause and replace.
	Compressor locked out	Determine cause for safety trip and reset lockout.
	One leg of 3-phase power dead.	Replace fuse or reset circuit breaker. Determine cause.
<b>Compressor Cycles (other than normally satisfying thermostat).</b>	Refrigerant overcharge or undercharge.	Recover refrigerant, evacuate system, and recharge to nameplate.
	Defective compressor.	Replace and determine cause.
	Insufficient line voltage.	Determine cause and correct.
	Blocked condenser.	Determine cause and correct.
	Defective overload.	Determine cause and replace.
	Defective thermostat.	Replace thermostat.
	Faulty condenser-fan motor.	Replace.
	Restriction in refrigerant system.	Locate restriction and remove.
<b>Compressor Operates continuously.</b>	Dirty air filter.	Replace filter.
	Unit undersized for load.	Decrease load or increase unit size.
	Thermostat set too low.	Reset thermostat.
	Low refrigerant charge.	Locate leak, repair, and recharge.
	Air in system.	Recover refrigerant, evacuate system, and recharge.
	Condenser coil dirty or restricted.	Clean coil or remove restriction.
	<b>Excessive Head Pressure.</b>	Dirty air filter.
Dirty condenser coil.		Clean coil.
Refrigerant overcharged.		Recover excess refrigerant.
Faulty TXV.		1. Check TXV bulb mounting and secure tightly to suction line. 2. Replace TXV if stuck open or closed.
Air in system.		Recover refrigerant, evacuate system, and recharge.
Condenser air restricted or air short-cycling.		Determine cause and correct.
<b>Head Pressure Too Low.</b>	Low refrigerant charge.	Check for leaks, repair, and recharge.
	Restriction in liquid tube.	Remove restriction.
<b>Excessive Suction Pressure.</b>	High heat load.	Check for source and eliminate.
	Faulty TXV.	1. Check TXV bulb mounting and secure tightly to suction line. 2. Replace TXV if stuck open or closed.
	Refrigerant overcharged.	Recover excess refrigerant.
<b>Suction Pressure Too Low.</b>	Dirty air filter.	Replace filter.
	Low refrigerant charge.	Check for leaks, repair, and recharge.
	Metering device or low side restricted.	Remove source of restriction.
	Faulty TXV.	1. Check TXV bulb mounting and secure tightly to suction line. 2. Replace TXV if stuck open or closed.
	Insufficient evaporator airflow.	Increase air quantity. Check filter and replace if necessary.
	Temperature too low in conditioned area.	Reset thermostat.
	Field-installed filter drier restricted.	Replace.

LEGEND

**TXV** — Thermostatic Expansion Valve

**Table 35 — Heating Service Analysis**

PROBLEM	CAUSE	REMEDY
<b>Burners Will Not Ignite.</b>	Misaligned spark electrodes.	Check flame ignition and sensor electrode positioning. Adjust as needed.
	No gas at main burners.	Check gas line for air; purge as necessary. After purging gas line of air, allow gas to dissipate for at least 5 minutes before attempting to relight unit. Check gas valve.
	Water in gas line.	Drain water and install drip leg to trap water.
	No power to furnace.	Check power supply, fuses, wiring, and circuit breaker.
	No 24 v power supply to control circuit.	Check transformer. Transformers with internal overcurrent protection require a cool-down period before resetting. Check 24-v circuit breaker; reset if necessary.
	Miswired or loose connections.	Check all wiring and wire nut connections.
	Burned-out heat anticipator in thermostat.	Replace thermostat.
	Broken thermostat wires.	Run continuity check. Replace wires if necessary.
<b>Inadequate Heating.</b>	Dirty air filter.	Clean or replace filter as necessary.
	Gas input to unit too low.	Check gas pressure at manifold. Clock gas meter for input. If too low, increase manifold pressure or replace with correct orifices.
	Unit undersized for application.	Replace with proper unit or add additional unit.
	Restricted airflow.	Clean filter, replace filter, or remove any restrictions.
	Blower speed too low.	Install alternate motor, if applicable, or adjust pulley to increase fan speed.
	Limit switch cycles main burners.	Check rotation of blower, thermostat heat anticipator settings, and temperature rise of unit. Adjust as needed.
	Too much outdoor air.	Adjust minimum position. Check economizer operation.
<b>Poor Flame Characteristics.</b>	Incomplete combustion (lack of combustion air) results in: Aldehyde odors, CO, sooting flame, or floating flame.	Check all screws around flue outlets and burner compartment. Tighten as necessary. Cracked heat exchanger. Replace heat exchanger.
		Overfired unit — reduce input, change orifices, or adjust gas line or manifold pressure.
		Check vent for restriction. Clean as necessary.
		Check orifice to burner alignment.
<b>Burners Will Not Turn Off.</b>	Unit is locked into Heating mode for a one minute minimum.	Wait until mandatory one minute time period has elapsed or power to unit.

**Table 36 — IGC Board LED Alarm Codes**

LED FLASH CODE	DESCRIPTION	ACTION TAKEN BY CONTROL	RESET METHOD	PROBABLE CAUSE
<b>On</b>	Normal Operation	—	—	—
<b>Off</b>	Hardware Failure	No gas heating.	—	Loss of power to the IGC. Check 5 amp fuse on IGC, power to unit, 24V circuit breaker, transformer, and wiring to the IGC.
<b>1 Flash</b>	Indoor Fan On/Off Delay Modified	5 seconds subtracted from On delay. 5 seconds added to Off delay (3 min max).	Power reset.	High temperature limit switch opens during heat exchanger warm-up period before fan-on delay expires. High temperature limit switch opens within 10 minutes of heat call (W) Off. See Limit Switch Fault.
<b>2 Flashes</b>	Limit Switch Fault	Gas valve and igniter Off. Indoor fan and inducer On.	Limit switch closed, or heat call (W) Off.	High temperature limit switch is open. Check the operation of the indoor (evaporator) fan motor. Ensure that the supply-air temperature rise is within the range on the unit nameplate. Check wiring and limit switch operation.
<b>3 Flashes</b>	Flame Sense Fault	Indoor fan and inducer On.	Flame sense normal. Power reset for LED reset.	The IGC sensed a flame when the gas valve should be closed. Check wiring, flame sensor, and gas valve operation.
<b>4 Flashes</b>	Four Consecutive Limit Switch Fault	No gas heating.	Heat call (W) Off. Power reset for LED reset.	4 consecutive limit switch faults within a single call for heat. See Limit Switch Fault.
<b>5 Flashes</b>	Ignition Fault	No gas heating.	Heat call (W) Off. Power reset for LED reset.	Unit unsuccessfully attempted ignition for 15 minutes. Check igniter and flame sensor electrode spacing, gaps, etc. Check flame sense and igniter wiring. Check gas valve operation and gas supply.
<b>6 Flashes</b>	Induced Draft Motor Fault	If heat off: no gas heating. If heat on: gas valve Off and inducer On.	Inducer sense normal, or heat call (W) Off.	Inducer sense On when heat call Off, or inducer sense Off when heat call On. Check wiring, voltage, and operation of IGC motor. Check speed sensor wiring to IGC.
<b>7 Flashes</b>	Rollout Switch Lockout	Gas valve and igniter Off. Indoor fan and inducer On.	Power reset.	Rollout switch has opened. Check gas valve operation. Check induced-draft blower wheel is properly secured to motor shaft.
<b>8 Flashes</b>	Internal Control Lockout	No gas heating.	Power reset.	IGC has sensed internal hardware or software error. If fault is not cleared by resetting 24 v power, replace the IGC.
<b>9 Flashes</b>	Temporary Software Lockout	No gas heating.	1 hour auto reset, or power reset.	Electrical interference is disrupting the IGC software.

**LEGEND**

**IGC** — Integrated Gas Unit Control  
**LED** — Light-Emitting Diode

**NOTES:**

1. There is a 3-second pause between alarm code displays.
2. If more than one alarm code exists, all applicable alarm codes will be displayed in numerical sequence.
3. Alarm codes on the IGC will be lost if power to the unit is interrupted.



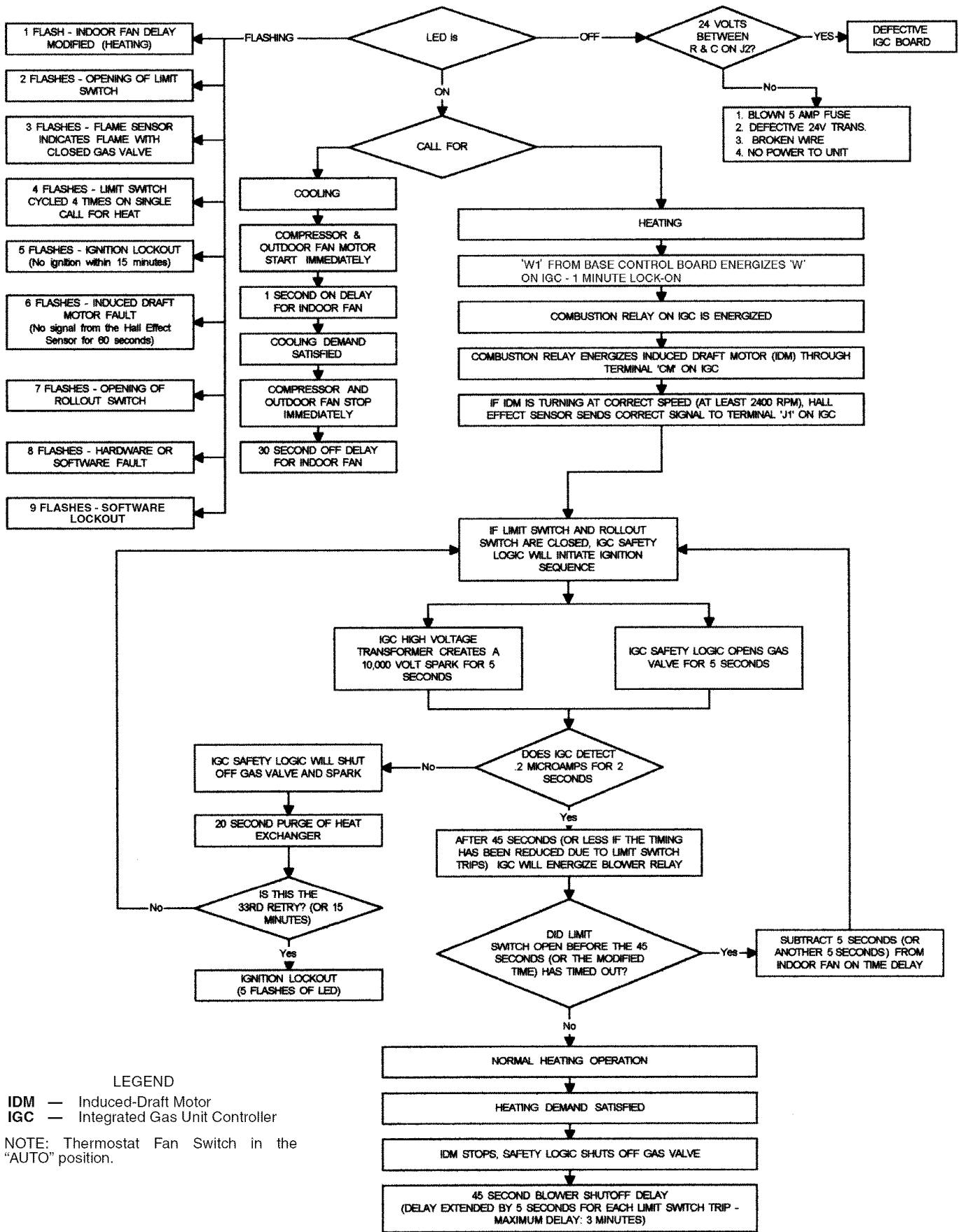


Fig. 43 — IGC Control (Heating and Cooling)

**EconoMi\$er IV Troubleshooting** — See Table 37 for EconoMi\$er IV input/output logic.

A functional view of the EconoMi\$er IV is shown in Fig. 43. Typical settings, sensor ranges, and jumper positions are also shown. An EconoMi\$er IV simulator program is available from Carrier to help with EconoMi\$er IV training and troubleshooting.

**ECONOMI\$ER IV PREPARATION** — This procedure is used to prepare the EconoMi\$er IV for troubleshooting. No troubleshooting or testing is done by performing the following procedure.

**NOTE:** This procedure requires a 9-v battery, 1.2 kilo-ohm resistor, and a 5.6 kilo-ohm resistor which are not supplied with the EconoMi\$er IV.

**IMPORTANT:** Be sure to record the positions of all potentiometers before starting troubleshooting.

1. Disconnect power at TR and TR1. All LEDs should be off. Exhaust fan contacts should be open.
2. Disconnect device at P and P1.
3. Jumper P to P1.
4. Disconnect wires at T and T1. Place 5.6 kilo-ohm resistor across T and T1.
5. Jumper TR to 1.
6. Jumper TR to N.
7. If connected, remove sensor from terminals S<sub>O</sub> and +. Connect 1.2 kilo-ohm 4074EJM checkout resistor across terminals S<sub>O</sub> and +.
8. Put 620-ohm resistor across terminals S<sub>R</sub> and +.
9. Set minimum position, DCV set point, and exhaust potentiometers fully CCW (counterclockwise).
10. Set DCV maximum position potentiometer fully CW (clockwise).
11. Set enthalpy potentiometer to D.
12. Apply power (24 vac) to terminals TR and TR1.

**DIFFERENTIAL ENTHALPY** — To check differential enthalpy:

1. Make sure EconoMi\$er IV preparation procedure has been performed.
2. Place 620-ohm resistor across S<sub>O</sub> and +.
3. Place 1.2 kilo-ohm resistor across S<sub>R</sub> and +. The Free Cool LED should be lit.
4. Remove 620-ohm resistor across S<sub>O</sub> and +. The Free Cool LED should turn off.
5. Return EconoMi\$er IV settings and wiring to normal after completing troubleshooting.

**SINGLE ENTHALPY** — To check single enthalpy:

1. Make sure EconoMi\$er IV preparation procedure has been performed.
2. Set the enthalpy potentiometer to A (fully CCW). The Free Cool LED should be lit.
3. Set the enthalpy potentiometer to D (fully CW). The Free Cool LED should turn off.
4. Return EconoMi\$er IV settings and wiring to normal after completing troubleshooting.

**DCV (Demand Controlled Ventilation) AND POWER EXHAUST** — To check DCV and Power Exhaust:

1. Make sure EconoMi\$er IV preparation procedure has been performed.
2. Ensure terminals AQ and AQ1 are open. The LED for both DCV and Exhaust should be off. The actuator should be fully closed.

3. Connect a 9-v battery to AQ (positive node) and AQ1 (negative node). The LED for both DCV and Exhaust should turn on. The actuator should drive to between 90 and 95% open.
4. Turn the Exhaust potentiometer CW until the Exhaust LED turns off. The LED should turn off when the potentiometer is approximately 90%. The actuator should remain in position.
5. Turn the DCV set point potentiometer CW until the DCV LED turns off. The DCV LED should turn off when the potentiometer is approximately 9 v. The actuator should drive fully closed.
6. Turn the DCV and Exhaust potentiometers CCW until the Exhaust LED turns on. The exhaust contacts will close 30 to 120 seconds after the Exhaust LED turns on.
7. Return EconoMi\$er IV settings and wiring to normal after completing troubleshooting.

**DCV MINIMUM AND MAXIMUM POSITION** — To check the DCV minimum and maximum position:

1. Make sure EconoMi\$er IV preparation procedure has been performed.
2. Connect a 9-v battery to AQ (positive node) and AQ1 (negative node). The DCV LED should turn on. The actuator should drive to between 90 and 95% open.
3. Turn the DCV Maximum Position potentiometer to midpoint. The actuator should drive to between 20 and 80% open.
4. Turn the DCV Maximum Position potentiometer to fully CCW. The actuator should drive fully closed.
5. Turn the Minimum Position potentiometer to midpoint. The actuator should drive to between 20 and 80% open.
6. Turn the Minimum Position Potentiometer fully CW. The actuator should drive fully open.
7. Remove the jumper from TR and N. The actuator should drive fully closed.
8. Return EconoMi\$er IV settings and wiring to normal after completing troubleshooting.

**SUPPLY-AIR INPUT** — To check supply-air input:

1. Make sure EconoMi\$er IV preparation procedure has been performed.
2. Set the Enthalpy potentiometer to A. The Free Cool LED turns on. The actuator should drive to between 20 and 80% open.
3. Remove the 5.6 kilo-ohm resistor and jumper T to T1. The actuator should drive fully open.
4. Remove the jumper across T and T1. The actuator should drive fully closed.
5. Return EconoMi\$er IV settings and wiring to normal after completing troubleshooting.

**ECONOMI\$ER IV TROUBLESHOOTING COMPLETION** — This procedure is used to return the EconoMi\$er IV to operation. No troubleshooting or testing is done by performing the following procedure.

1. Disconnect power at TR and TR1.
2. Set enthalpy potentiometer to previous setting.
3. Set DCV maximum position potentiometer to previous setting.
4. Set minimum position, DCV set point, and exhaust potentiometers to previous settings.
5. Remove 620-ohm resistor from terminals S<sub>R</sub> and +.
6. Remove 1.2 kilo-ohm checkout resistor from terminals S<sub>O</sub> and +. If used, reconnect sensor from terminals S<sub>O</sub> and +.

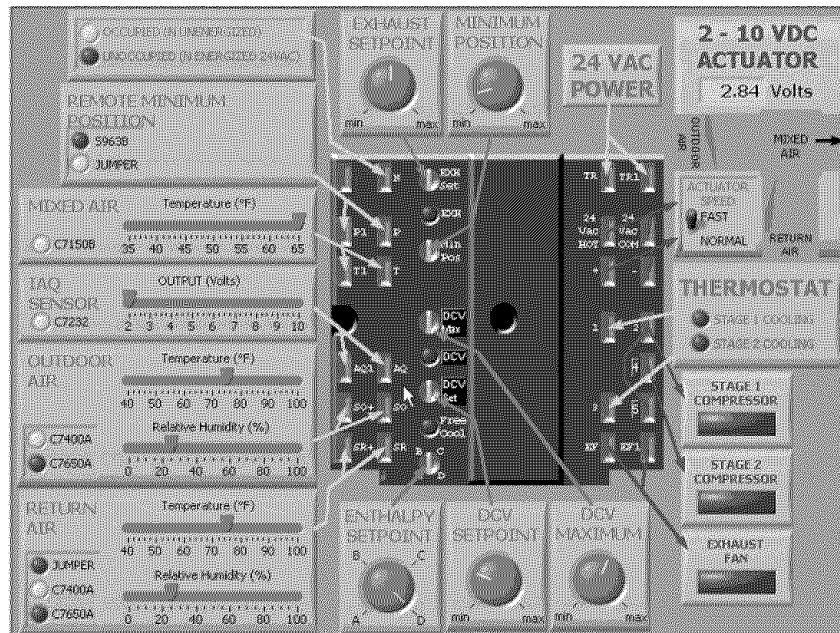
7. Remove jumper from TR to N.
8. Remove jumper from TR to L.
9. Remove 5.6 kilo-ohm resistor from T and T1. Reconnect wires at T and T1.
10. Remove jumper from P to P1. Reconnect device at P and P1.
11. Apply power (24 vac) to terminals TR and TR1.

**Table 37 — EconoMiSer IV Input/Output Logic**

Demand Control Ventilation (DCV)	INPUTS				OUTPUTS			
	Enthalpy*		Y1	Y2	Compressor		N Terminal†	
	Outdoor	Return			Stage 1	Stage 2	Occupied	Unoccupied
Below set (DCV LED Off)	High (Free Cooling LED Off)	Low	On	On	On	On	Minimum position	Closed
			On	Off	On	Off		
			Off	Off	Off	Off		
	Low (Free Cooling LED On)	High	On	On	On	Off	Modulating** (between min. position and full-open)	Modulating** (between closed and full-open)
			On	Off	Off	Off		
			Off	Off	Off	Off		
Above set (DCV LED On)	High (Free Cooling LED Off)	Low	On	On	On	On	Modulating†† (between min. position and DCV maximum)	Modulating†† (between closed and DCV maximum)
			On	Off	On	Off		
			Off	Off	Off	Off		
	Low (Free Cooling LED On)	High	On	On	On	Off	Modulating***	Modulating†††
			On	Off	Off	Off		
			Off	Off	Off	Off		

\*For single enthalpy control, the module compares outdoor enthalpy to the ABCD set point.  
 †Power at N terminal determines Occupied/Unoccupied setting: 24 vac (Occupied), no power (Unoccupied).  
 \*\*Modulation is based on the supply-air sensor signal.  
 ††Modulation is based on the DCV signal.

\*\*\*Modulation is based on the greater of DCV and supply-air sensor signals, between minimum position and either maximum position (DCV) or fully open (supply-air signal).  
 †††Modulation is based on the greater of DCV and supply-air sensor signals, between closed and either maximum position (DCV) or fully open (supply-air signal).



**Fig. 43 — EconoMiSer IV Functional View**





## Free Manuals Download Website

<http://myh66.com>

<http://usermanuals.us>

<http://www.somanuals.com>

<http://www.4manuals.cc>

<http://www.manual-lib.com>

<http://www.404manual.com>

<http://www.luxmanual.com>

<http://aubethermostatmanual.com>

Golf course search by state

<http://golfingnear.com>

Email search by domain

<http://emailbydomain.com>

Auto manuals search

<http://auto.somanuals.com>

TV manuals search

<http://tv.somanuals.com>