

BELKIN®

**POWERLINE AV
NETWORKING ADAPTERS**



User Manual

F5D4072

Table of Contents

1. Introduction	1
Features	1
Product Specifications	2
System Requirements	3
Package Contents	3
2. Installing and Setting Up the Adapters.	4
3. Configuration	5
4. Information	6

Introduction

Thank you for purchasing the Powerline AV Networking Adapter (the Adapter). Most people don't enjoy buying long and expensive Ethernet cables or pulling the cables from one place to another, but the Adapter offers one of the easiest ways to enjoy home or small-business networking. Users can now experience a total network solution with the Adapter. The Powerline AV Networking Adapter operates on the HomePlug® Powerline Specification 2.0 standard, providing up to 200Mbps* bandwidth over home AC wiring. Since the home power lines are the most pervasive medium in households with multiple outlets in every room, the Adapter allows multiple home desktop and notebook computers to be networked to share an Internet connection, printers, and files, and play games without any additional wiring. The advanced signal processing is capable of maintaining coverage throughout the entire house, even across different phase rings.

The installation of the Adapter only requires that a 10/100Mbps network adapter is installed on the computers. This makes the Powerline AV Networking Adapter compatible with any device, including Mac, Windows, and UNIX machines.

For security, all HomePlug devices are equipped with 128-bit AES encryption. The private home power grid plus encryption makes HomePlug significantly more secure than competing technologies.

The Powerline AV Networking Adapter provides the best solution for no-new-wires home networking. With easy plug-and-play installation, and the reliability of HomePlug Ethernet's products, the Powerline AV Networking Adapter is the best solution for high-speed networking.

Features

- Up to 200Mbps* bandwidth over standard home power lines
- HomePlug signal easily passes through circuit breaker
- 128-bit AES encryption ensures data security
- Encryption completed by hardware, without sacrifice to bandwidth
- Uses IEEE 802.3 computer interface
- Plug-and-play installation
- HomePlug Powerline Specification 2.0-compliant
- Coexistence with HomePlug 1.0 and 1.0 Turbo networks

Introduction

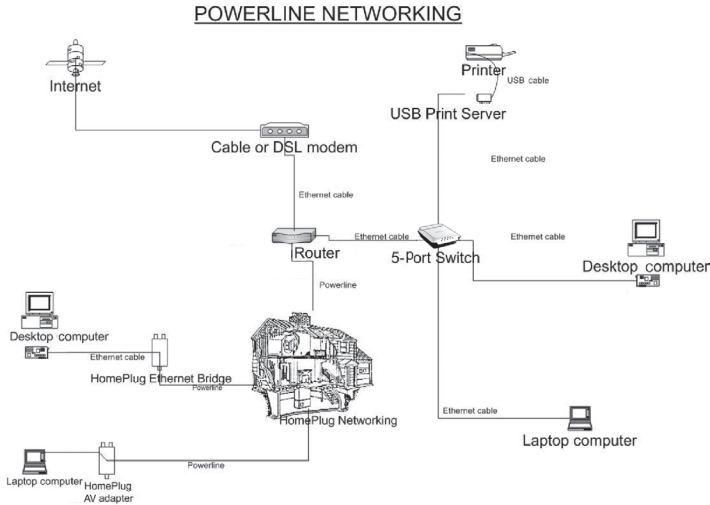

Product Specifications

Computer Interface: IEEE 802.3/802.3u

Operating Temperature: 32–104 degrees F (0–40 degrees C)

Storage Temperature: -4–176 degrees F (-20–80 degrees C)

Humidity: Max. 5%–90% (non-condensing)

*The standard transmission rate—200Mbps—is the physical data rate. Actual data throughput will be lower.



Introduction

Power LED

- Solid Blue – Connected to powerline
- Off – Power off
- Blinking Blue – During encryption setup
- Solid Blue – Encryption setup successful
- Double Flash – Fail in encryption

Powerline Link LED

- Blinking – Powerline data transmitting or receiving
- Color Green – Link rate excellent: greater than 20Mbps
- Color Yellow – Link rate normal: 10–20Mbps
- Color Red – Link rate low: 0–10Mbps
- Off – No activity

Ethernet Link LED

- Solid Blue – 10/100Mbps port linked
- Blinking Blue – 10/100Mbps port transmitting or receiving
- Off – No Ethernet link

System Requirements

- At least 2 HomePlug devices
- Available Ethernet port on each computer or network device
- Available power outlet
- Standard home powerline wiring
- CD-ROM drive

Package Contents

- Two Powerline AV Networking Adapters
- HomePlug Quick Installation Guide
- HomePlug User Manual (on CD)
- CD-ROM
- Limited Warranty Card
- Two Power Cables
- Two CAT5/RJ45 Ethernet Cables
- Two Wall Plug Adapters

Installing and Setting Up the Adapters

Overview

Installation of the Powerline AV Networking Adapter takes only seconds and does not require setting up long wires throughout the house. Simply plug the units directly into any available wall outlet and connect to any device with an Ethernet port. Users have the option to randomly change the security password for their powerline network.

Hardware Setup

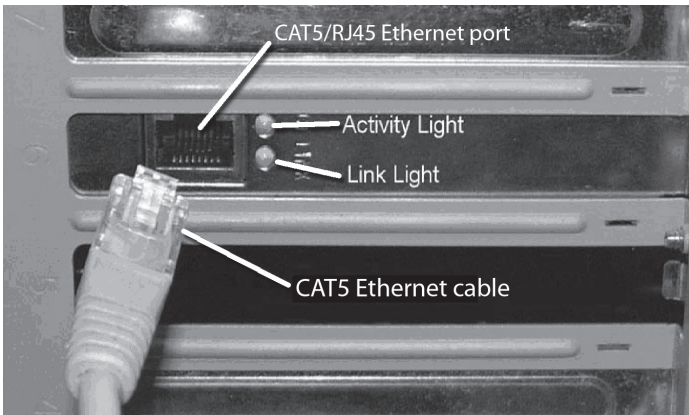

1. Plug your network cable into the computer's RJ45 network adapter port.
2. Plug the other end of your network cable into the RJ45 port located at the back of the Adapter.
3. Plug the power cable or wall adapter into the power connector at the back of the Adapter.
4. Insert the power plug of your power cable or wall adapter directly into a power outlet in the wall.

NOTE: Do not plug the device into a UPS or power strip with surge protection. The Adapter has its own power filter for protection against surges.

Configuration

Overview

The Adapter uses 128-bit AES encryption to block access from the outside. By default, the protection is enabled. However, it is recommended that you change the default network password with the “Encryption” button located on the units.



Reset Encryption

Changing the Network Password

1. With both Adapters plugged into the wall, press the “Encryption” button on the first unit for 10 seconds. The password on this Adapter has now been changed to a random value.
2. Next, press the “Encryption” button on this unit for more than 0.5 seconds, but less than three seconds.
3. Within two minutes, press the “Encryption” button on the second unit for more than 0.5 seconds, but less than three seconds.
4. The new network password has now been saved to the second unit. The password will not be lost, even if the Adapters are unplugged from the wall.

Adding Another Adapter to the Network

1. If the default network password has been changed, a new Adapter will have to load the new password before it can join the network.
2. Press the “Encryption” button on an encrypted unit for more than 0.5 seconds, but less than three seconds.
3. Within two minutes, press the “Encryption” button on the new unit for more than 0.5 seconds, but less than three seconds.
4. The new device has now been loaded with the network password and added to the current powerline network

Resetting to Factory Defaults

Using a pointed object, press and hold the “Reset” button for one second to restore defaults. This procedure resets the network password to the default out-of-box value.

Information

Technical Support

You can find technical support information at www.belkin.com/networking or www.belkin.com. If you want to contact technical support by phone, please call:

US: 877-736-5771

800-223-5546 ext. 2263

310-898-1100 ext. 2263

Australia: 1800 235 546

New Zealand: 0800 235 546

Singapore: 65 64857620

Information

FCC Statement

DECLARATION OF CONFORMITY WITH FCC RULES FOR
ELECTROMAGNETIC COMPATIBILITY

We, Belkin International, Inc., of 501 West Walnut Street,
Compton, CA 90220, declare under our sole responsibility
that the product,

F5D4072

to which this declaration relates,
complies with Part 15 of the FCC Rules. Operation is
subject to the following two conditions: (1) this device
may not cause harmful interference, and (2) this device
must accept any interference received, including
interference that may cause undesired operation.

Caution: Exposure to Radio Frequency Radiation.

The radiated output power of this device is far below the FCC radio frequency exposure limits. Nevertheless, the device shall be used in such a manner that the potential for human contact during normal operation is minimized.

When connecting an external antenna to the device, the antenna shall be placed in such a manner to minimize the potential for human contact during normal operation. In order to avoid the possibility of exceeding the FCC radio frequency exposure limits, human proximity to the antenna shall not be less than 20cm (8 inches) during normal operation.

Federal Communications Commission Notice

This equipment has been tested and found to comply with the limits for a Class B digital device, pursuant to Part 15 of the FCC Rules. These limits are designed to provide reasonable protection against harmful interference in a residential installation.

This equipment generates, uses, and can radiate radio frequency energy. If this equipment does cause harmful interference to radio or television reception, which can be determined by turning the equipment off and on, the user is encouraged to try and correct the interference by one or more of the following measures:

- Reorient or relocate the receiving antenna.
- Increase the distance between the equipment and the receiver.
- Connect the equipment to an outlet on a circuit different from that to which the receiver is connected.
- Consult the dealer or an experienced radio/TV technician for help.

Information

Modifications

The FCC requires the user to be notified that any changes or modifications to this device that are not expressly approved by Belkin International, Inc., may void the user's authority to operate the equipment.

Europe – EU Declaration of Conformity

This device complies with the essential requirements of the R&TTE Directive 1999/5/EC. The following test methods have been applied in order to prove presumption of conformity with the essential requirements of the R&TTE Directive 1999/5/EC:

- EN60950-1:2001 A11:2004

Safety of Information Technology Equipment

CE0560!

Česky [Czech]	<i>[Jméno výrobce]</i> tímto prohlašuje, že tento <i>[typ zařízení]</i> je ve shodě se základními požadavky a dalšími příslušnými ustanoveními směrnice 1999/5/ES.
Dansk [Danish]	Undertegnede <i>[fabrikantens navn]</i> erklærer herved, at følgende udstyr <i>[udstyrets typebetegnelse]</i> overholder de væsentlige krav og øvrige relevante krav i direktiv 1999/5/EF.
Deutsch [German]	Hiermit erkläre <i>[Name des Herstellers]</i> , dass sich das Gerät <i>[Gerätetyp]</i> in Übereinstimmung mit den grundlegenden Anforderungen und den übrigen einschlägigen Bestimmungen der Richtlinie 1999/5/EG befindet.
Eesti [Estonian]	Käesolevaga kinnitab <i>[tootja nimi = name of manufacturer]</i> seadme <i>[seadme tüüp = type of equipment]</i> vastavust direktiivi 1999/5/EÜ põhinõuetele ja nimetatud direktiivist tulenevatele teistele asjakohastele sätetele.
English	Hereby, <i>[name of manufacturer]</i> , declares that this <i>[type of equipment]</i> is in compliance with the essential requirements and other relevant provisions of Directive 1999/5/EC.
Español [Spanish]	Por medio de la presente <i>[nombre del fabricante]</i> declara que el <i>[clase de equipo]</i> cumple con los requisitos esenciales y cualesquiera otras disposiciones aplicables o exigibles de la Directiva 1999/5/CE.
Ελληνική [Greek]	ΜΕ ΤΗΝ ΠΑΡΟΥΣΑ <i>[name of manufacturer]</i> ΔΗΛΩΝΕΙ ΟΤΙ <i>[type of equipment]</i> ΣΥΜΜΟΡΦΩΝΕΤΑΙ ΠΡΟΣ ΤΙΣ ΟΥΣΙΩΔΕΙΣ ΑΠΑΙΤΗΣΕΙΣ ΚΑΙ ΤΙΣ ΛΟΙΠΕΣ ΣΧΕΤΙΚΕΣ ΔΙΑΤΑΞΕΙΣ ΤΗΣ ΟΔΗΓΙΑΣ 1999/5/EK.
Français [French]	Par la présente <i>[nom du fabricant]</i> déclare que l'appareil <i>[type d'appareil]</i> est conforme aux exigences essentielles et aux autres dispositions pertinentes de la directive 1999/5/CE.
Italiano [Italian]	Con la presente <i>[nome del costruttore]</i> dichiara che questo <i>[tipo di apparecchio]</i> è conforme ai requisiti essenziali ed alle altre disposizioni pertinenti stabilite dalla direttiva 1999/5/CE.
Latviski [Latvian]	Ar šo <i>[name of manufacturer / izgatavotāja nosaukums]</i> deklarē, ka <i>[type of equipment / iekārtas tips]</i> atbilst Direktīvas 1999/5/EK būtiskajām prasībām un citiem ar to saistītajiem noteikumiem.

Information

1
2
3
4

section

Lietuvių [Lithuanian]	Šiuo <i>[manufacturer name]</i> deklaruoja, kad šis <i>[equipment type]</i> atitinka esminius reikalavimus ir kitas 1999/5/EB Direktyvos nuostatas.
Nederlands [Dutch]	Hierbij verklaart <i>[naam van de fabrikant]</i> dat het toestel <i>[type van toestel]</i> in overeenstemming is met de essentiële eisen en de andere relevante bepalingen van richtlijn 1999/5/EG.
Malti [Maltese]	Hawnhekk, <i>[isem tal-manifattur]</i> , jiddikjara li dan <i>[il-mudel tal-prodott]</i> jikkonforma mal-htigijiet essenzjali u ma provvedimenti oħrajn rilevanti li hemm fid-Direttiva 1999/5/EC.
Magyar [Hungarian]	Alulírott, <i>[gyártó neve]</i> nyilatkozom, hogy a <i>[... típus]</i> megfelel a vonatkozó alapvető követelményeknek és az 1999/5/EC irányelv egyéb előírásainak.
Polski [Polish]	Niniejszym <i>[nazwa producenta]</i> oświadczam, że <i>[nazwa wyrobu]</i> jest zgodny z zasadniczymi wymogami oraz pozostałymi stosownymi postanowieniami Dyrektywy 1999/5/EC.
Português [Portuguese]	<i>[Nome do fabricante]</i> declara que este <i>[tipo de equipamento]</i> está conforme com os requisitos essenciais e outras disposições da Directiva 1999/5/CE.
Slovensko [Slovenian]	<i>[Ime proizvajalca]</i> izjavlja, da je ta <i>[tip opreme]</i> v skladu z bistvenimi zahtevami in ostalimi relevantnimi določili direktive 1999/5/ES.
Slovensky [Slovak]	[Meno výrobcu] týmto vyhlasuje, že [typ zariadenia] spĺňa základné požiadavky a všetky príslušné ustanovenia Smernice 1999/5/ES.
Suomi [Finnish]	<i>[Valmistaja = manufacturer]</i> vakuuttaa täten että <i>[type of equipment = laiteen tyyppimerkintä]</i> tyypinen laite on direktiivin 1999/5/EY oleellisten vaatimusten ja sitä koskevien direktiivin muiden ehtojen mukainen.
Svenska [Swedish]	Härmed intygar <i>[företag]</i> att denna <i>[utrustningstyp]</i> står i överensstämmelse med de väsentliga egenskapskrav och övriga relevanta bestämmelser som framgår av direktiv 1999/5/EG.

Information

Belkin International, Inc., Limited Lifetime Product Warranty

What this warranty covers.

Belkin International, Inc. (“Belkin”) warrants to the original purchaser of this Belkin product that the product shall be free of defects in design, assembly, material, or workmanship.

What the period of coverage is.

Belkin warrants the Belkin product for the lifetime of the product.

What will we do to correct problems?

Product Warranty.

Belkin will repair or replace, at its option, any defective product free of charge (except for shipping charges for the product). Belkin reserves the right to discontinue any of its products without notice, and disclaims any limited warranty to repair or replace any such discontinued products. In the event that Belkin is unable to repair or replace the product (for example, because it has been discontinued), Belkin will offer either a refund or a credit toward the purchase of another product from Belkin.com in an amount equal to the purchase price of the product as evidenced on the original purchase receipt as discounted by its natural use.

What is not covered by this warranty?

All above warranties are null and void if the Belkin product is not provided to Belkin for inspection upon Belkin’s request at the sole expense of the purchaser, or if Belkin determines that the Belkin product has been improperly installed, altered in any way, or tampered with. The Belkin Product Warranty does not protect against acts of God such as flood, lightning, earthquake, war, vandalism, theft, normal-use wear and tear, erosion, depletion, obsolescence, abuse, damage due to low voltage disturbances (i.e. brownouts or sags), non-authorized program, or system equipment modification or alteration.

How to get service.

To get service for your Belkin product you must take the following steps:

1. Contact Belkin International, Inc.

USA: 501 W. Walnut St., Compton, CA 90220, Attn: Customer Service, or call (800)-223-5546, within 15 days of the Occurrence.

Europe: See contact information on back page.

Australia: call 1800-235-546 within 15 days of the Occurrence.

New Zealand: call 0800-235-546 within 15 days of the Occurrence.

Be prepared to provide the following information:

- a. The part number of the Belkin product.
 - b. Where you purchased the product.
 - c. When you purchased the product.
 - d. Copy of original receipt.
2. Your Belkin Customer Service Representative will then instruct you on how to forward your receipt and Belkin product and how to proceed with your claim.

Information

Belkin reserves the right to review the damaged Belkin product. All costs of shipping the Belkin product to Belkin for inspection shall be borne solely by the purchaser. If Belkin determines, in its sole discretion, that it is impractical to ship the damaged equipment to Belkin, Belkin may designate, in its sole discretion, an equipment repair facility to inspect and estimate the cost to repair such equipment. The cost, if any, of shipping the equipment to and from such repair facility and of such estimate shall be borne solely by the purchaser. Damaged equipment must remain available for inspection until the claim is finalized. Whenever claims are settled, Belkin reserves the right to be subrogated under any existing insurance policies the purchaser may have.

How state law relates to the warranty.

THIS WARRANTY CONTAINS THE SOLE WARRANTY OF BELKIN. THERE ARE NO OTHER WARRANTIES, EXPRESSED OR, EXCEPT AS REQUIRED BY LAW, IMPLIED, INCLUDING THE IMPLIED WARRANTY OR CONDITION OF QUALITY, MERCHANTABILITY OR FITNESS FOR A PARTICULAR PURPOSE, AND SUCH IMPLIED WARRANTIES, IF ANY, ARE LIMITED IN DURATION TO THE TERM OF THIS WARRANTY.

Some states do not allow limitations on how long an implied warranty lasts, so the above limitations may not apply to you.

IN NO EVENT SHALL BELKIN BE LIABLE FOR INCIDENTAL, SPECIAL, DIRECT, INDIRECT, CONSEQUENTIAL OR MULTIPLE DAMAGES SUCH AS, BUT NOT LIMITED TO, LOST BUSINESS OR PROFITS ARISING OUT OF THE SALE OR USE OF ANY BELKIN PRODUCT, EVEN IF ADVISED OF THE POSSIBILITY OF SUCH DAMAGES.

This warranty gives you specific legal rights, and you may also have other rights, which may vary from state to state. Some states do not allow the exclusion or limitation of incidental, consequential, or other damages, so the above limitations may not apply to you.

BELKIN®

POWERLINE AV NETWORKING ADAPTERS

BELKIN®

www.belkin.com

Belkin Tech Support

US: 877-736-5771
800-223-5546 ext. 2263
310-898-1100 ext. 2263

Australia: 1800 235 546
New Zealand: 0800 235 546
Singapore: 65 64857620

Belkin International, Inc.

501 West Walnut Street
Los Angeles, CA 90220, USA
310-898-1100
310-898-1111 fax

Belkin Ltd.

4 Pioneer Avenue
Tuggerah Business Park
Tuggerah, NSW 2259, Australia
+61 (0) 2 4350 4600
+61 (0) 2 4350 4700 fax

AUSTRIA

08 - 20 20 07 66
<http://www.belkin.com/uk>

BELGIUM

07 07 00 073
<http://www.belkin.com/nl>

CZECH REPUBLIC

23 900 04 06
<http://www.belkin.com/uk>

DENMARK

701 22 403
<http://www.belkin.com/uk>

FINLAND

00800 - 22 35 54 60
<http://www.belkin.com/uk>

FRANCE

08 - 25 54 00 26
<http://www.belkin.com/fr>

GERMANY

0180 - 500 57 09
<http://www.belkin.com/de>

GREECE

00800 - 44 14 23 90
<http://www.belkin.com/uk>

HUNGARY

06 - 17 77 49 06
<http://www.belkin.com/uk>

ICELAND

800 8534
<http://www.belkin.com/uk>

IRELAND

0818 55 50 06
<http://www.belkin.com/uk>

ITALY

02 - 69 43 02 51
<http://www.belkin.com/it/support/tech>

LUXEMBOURG

34 20 80 8560
<http://www.belkin.com/uk>

NETHERLANDS

0900 - 040 07 90 €0.10 per minute
<http://www.belkin.com/nl>

NORWAY

815 00 287
<http://www.belkin.com/uk>

POLAND

00800 - 441 17 37
<http://www.belkin.com/uk>

PORTUGAL

707 200 676
<http://www.belkin.com/uk>

RUSSIA

495 580 9541
<http://www.belkin.com/uk>

SOUTH AFRICA

0800 - 99 15 21
<http://www.belkin.com/uk>

SPAIN

902 - 02 43 66
<http://www.belkin.com/es/support/tech>

SWEDEN

07 - 71 40 04 53
<http://www.belkin.com/se/support/tech>

SWITZERLAND

08 - 48 00 02 19
<http://www.belkin.com/uk>

UNITED KINGDOM

0845 - 607 77 87
<http://www.belkin.com/uk>

OTHER COUNTRIES

+44 - 1933 35 20 00

© 2008 Belkin International, Inc. All rights reserved. All trade names are registered trademarks of respective manufacturers listed. Windows and Windows Vista are either registered trademarks or trademarks of Microsoft Corporation in the United States and/or other countries.

PM00233-A

Free Manuals Download Website

<http://myh66.com>

<http://usermanuals.us>

<http://www.somanuals.com>

<http://www.4manuals.cc>

<http://www.manual-lib.com>

<http://www.404manual.com>

<http://www.luxmanual.com>

<http://aubethermostatmanual.com>

Golf course search by state

<http://golfingnear.com>

Email search by domain

<http://emailbydomain.com>

Auto manuals search

<http://auto.somanuals.com>

TV manuals search

<http://tv.somanuals.com>