INSTALLATION INSTRUCTIONS

WALL MOUNTED VARIABLE CAPACITY ENVIRONMENTAL CONTROL UNITS

MODELS

W3RV1

W3LV1

W5RV1

W5LV1

W6RV1

W6LV1



Bard Manufacturing Company, Inc.
Bryan, Ohio 43506
Since 1914...Moving ahead just as planned.

Manual : 2100-538E
Supersedes: 2100-538D
File: Volume III Tab 16
Date: 12-15-11

Contents

Getting Other Information and Publications	3	Start Up	
Wall Mount General Information		General	14
ECU Wall Mount Model Nomenclature	4	Topping Off System Charge	14
Shipping Damage	4	Safety Practices	14
General	4	Important Installer Note	15
Duct Work	5	High Pressure Switch	15
Filters	5	Three Phase Scroll Compressor	15
Fresh Air Intake	5	Phase Monitor	15
Condensate Drain	5	Service Hints	15
		Digital Controller	15
Installation Instructions		Sequence of Operation	16 & 17
Wall Mounting Information	6	Lead/Lag Sequence	17
Mounting the Unit	6	Compressor Control Module	18
Clearances Required	6	Adjustments	18
Minimum Clearances	6	Pressure Service Ports	18
Wiring – Main Power	13	Troubleshooting	
Wiring – Low Voltage Wiring	13	Fan Blade Setting Dimensions	19
Digital Thermostat/Controller	13	Removal of Fan Shroud	19
Wiring Diagram	13	Refrigerant Charge	19
Figures		Tables	
Figure 1 Fresh Air Damper Assembly	5	Table 1 Fan Blade Dimensions	19
Figure 2 Unit Dimensions	7	Table 2 Cooling Pressure	20
Figure 3A Mounting Instructions	8	Table 3 Electrical Specifications W*R/LV	21
Figure 3B Mounting Instructions	9	Table 4 Recommended Airflow	22
Figure 4 Electric Heat Clearance	10	Table 5 Maximum ESP Electric Heat Only	22
Figure 5 Wall Mounting Instructions	11	Table 6 Electric Heat	22
Figure 6 Wall Mounting Instructions	11	Table 7 Vent & Control Options	23
Figure 7 Common Wall Mounting Installations	12		
Figure 8 Fan Blade Setting	19		

GETTING OTHER INFORMATION AND PUBLICATIONS

These publications can help you install the air conditioner or heat pump. You can usually find these at your local library or purchase them directly from the publisher. Be sure to consult current edition of each standard.

National Electrical Code ANSI/NFPA 70

Standard for the Installation ANSI/NFPA 90A
of Air Conditioning and Ventilating Systems

Standard for Warm Air ANSI/NFPA 90B
Heating and Air Conditioning Systems

Load Calculation for ACCA Manual J
Residential Winter and Summer Air Conditioning

Duct Design for Residential ACCA Manual D
Winter and Summer Air Conditioning and Equipment
Selection

FOR MORE INFORMATION, CONTACT THESE PUBLISHERS:

ACCA **Air Conditioning Contractors of America**
1712 New Hampshire Ave. N.W.
Washington, DC 20009
Telephone: (202) 483-9370
Fax: (202) 234-4721

ANSI **American National Standards Institute**
11 West Street, 13th Floor
New York, NY 10036
Telephone: (212) 642-4900
Fax: (212) 302-1286

ASHRAE **American Society of Heating, Refrigeration
and Air Conditioning Engineers, Inc.**
1791 Tullie Circle, N.E.
Atlanta, GA 30329-2305
Telephone: (404) 636-8400
Fax: (404) 321-5478

NFPA **National Fire Protection Association**
Batterymarch Park
P.O. Box 9101
Quincy, MA 02269-9901
Telephone: (800) 344-3555
Fax: (617) 984-7057

Manufactured under the following
U.S. Patent numbers:
5,485,878; 5,301,744

WALL MOUNT GENERAL INFORMATION

Environmental Control Unit (ECU) Wall-Mount Model Nomenclature

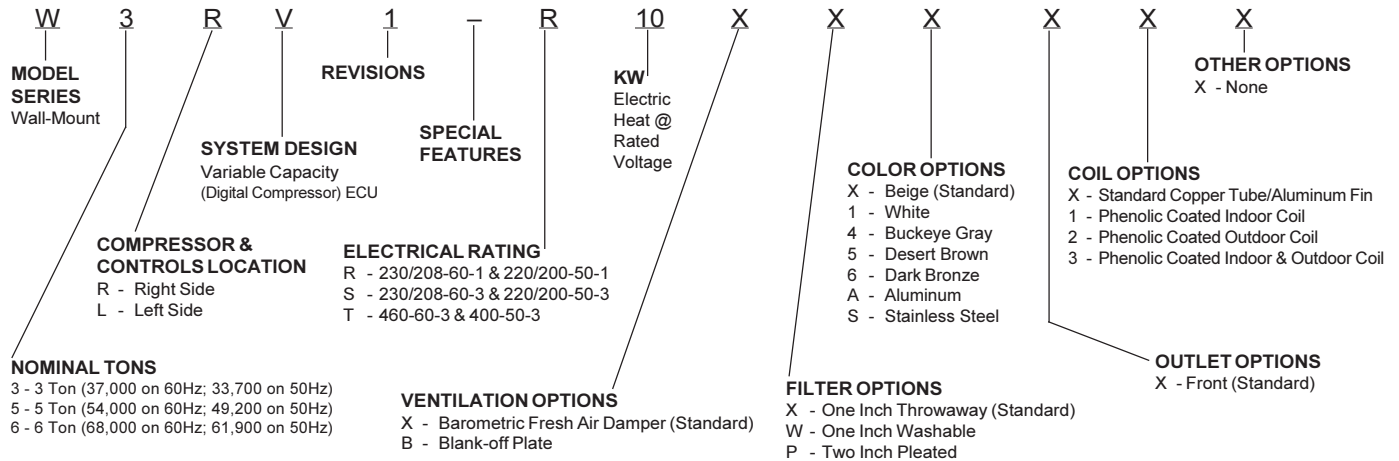

NOTE: Vent options X and B are without exhaust capability. May require separate field supplied barometric relief in building.

SHIPPING DAMAGE

Upon receipt of equipment, the carton should be checked for external signs of shipping damage. If damage is found, the receiving party must contact the last carrier immediately, preferably in writing, requesting inspection by the carrier's agent.

GENERAL

The equipment covered in this manual is to be installed by trained, experienced service and installation technicians.

The refrigerant system is completely assembled and charged. All internal wiring is complete.

The unit is designed for use with or without duct work. Flanges are provided for attaching the supply and return ducts.

These instructions explain the recommended method to install the air cooled self-contained unit and the electrical wiring connections to the unit.

These instructions and any instructions packaged with any separate equipment required to make up the entire air conditioning system should be carefully read before beginning the installation. Note particularly "Starting Procedure" and any tags and/or labels attached to the equipment.

While these instructions are intended as a general recommended guide, they do not supersede any national and/or local codes in any way. Authorities having jurisdiction should be consulted before the installation is made. See Page 3 for information on codes and standards.

Size of unit for a proposed installation should be based on heat loss calculation made according to methods of Air Conditioning Contractors of America (ACCA). The air duct should be installed in accordance with the Standards of the National Fire Protection Association for the Installation of Air Conditioning and Ventilating Systems of Other Than Residence Type, NFPA No. 90A, and Residence Type Warm Air Heating and Air Conditioning Systems, NFPA No. 90B. Where local regulations are at a variance with instructions, installer should adhere to local codes.

DUCT WORK

All duct work, supply and return, must be properly sized for the design airflow requirement of the equipment. Air Conditioning Contractors of America (ACCA) is an excellent guide to proper sizing. All duct work or portions thereof not in the conditioned space should be properly insulated in order to both conserve energy and prevent condensation or moisture damage.

Refer to Maximum ESP of operation Electric Heat Table 5.

Design the duct work according to methods given by the Air Conditioning Contractors of America (ACCA). When duct runs through unheated spaces, it should be insulated with a minimum of one inch of insulation. Use insulation with a vapor barrier on the outside of the insulation. Flexible joints should be used to connect the duct work to the equipment in order to keep the noise transmission to a minimum.

For model series W3R/LV, W5R/LV and W6R/LV a 1/4 inch clearance to combustible material for the first three feet of duct attached to the outlet air frame is required. See Wall Mounting Instructions and Figures 3A, 3B and 4 for further details.

Ducts through the walls must be insulated and all joints taped or sealed to prevent air or moisture entering the wall cavity.

Some installations may not require any return air duct. A metallic return air grille is required with installations not requiring a return air duct. The spacing between louvers on the grille shall not be larger than 5/8 inch.

Any grille that meets with 5/8 inch louver criteria may be used. It is recommended that Bard Return Air Grille Kit RG2 through RG5 or RFG2 through RFG5 be installed when no return duct is used. Contact distributor or factory for ordering information. If using a return air filter grille, filters must be of sufficient size to allow a maximum velocity of 400 fpm.

NOTE: If no return air duct is used, applicable installation codes may limit this cabinet to installation only in a single story structure.

FILTERS

A 1-inch throwaway filter is standard with each unit. The filter slides into position making it easy to service. This filter can be serviced from the outside by removing the filter access panel. A 1-inch washable filter and 2-inch pleated filter are also available as optional accessories. The internal filter brackets are adjustable to accommodate the 2-inch filter by bending two (2) tabs down on each side of the filter support bracket.

FRESH AIR INTAKE

All units are built with fresh air inlet slots punched in the service door.

If the unit is equipped with a fresh air damper assembly, the assembly is shipped already attached to the unit. The damper blade is locked in the closed position. To allow the damper to operate, the maximum and minimum blade position stops must be installed. See Figure 1.

All capacity, efficiency and cost of operation information is based upon the fresh air blank-off plate in place and is recommended for maximum energy efficiency.

The blank-off plate is available upon request from the factory and is installed in place of the fresh air damper shipped with each unit.

CONDENSATE DRAIN

A plastic drain hose extends from the drain pan at the top of the unit down to the unit base. There are openings in the unit base for the drain hose to pass through. In the event the drain hose is connected to a drain system of some type, it must be an open or vented type system to assure proper drainage.

**FIGURE 1
FRESH AIR DAMPER**

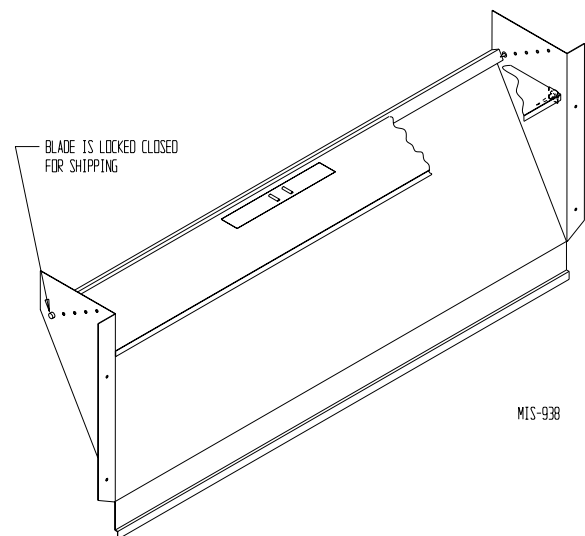

INSTALLATION INSTRUCTIONS

WALL MOUNTING INFORMATION

1. Two holes for the supply and return air openings must be cut through the wall as shown in Figures 3A & 3B.
2. On wood frame walls, the wall construction must be strong and rigid enough to carry the weight of the unit without transmitting any unit vibration.
3. Concrete block walls must be thoroughly inspected to insure that they are capable of carrying the weight of the installed unit.

MOUNTING THE UNIT

1. These units are secured by wall mounting brackets which secure the unit to the outside wall surface at both sides. A bottom mounting bracket, attached to skid for shipping, is provided for ease of installation, but is not required.
2. The supply air duct flange and the first 3 feet of supply air duct require a minimum of 1/4 inch clearance to combustible material for model series W3R/LV, W5R/LV and W6R/LV. However, it is generally recommended that a 1-inch clearance is used for ease of installation and maintaining the required clearance to combustible material. See Figures 3A & 3B for details on opening sizes.
3. Locate and mark lag bolt locations and bottom mounting bracket location. See Figures 3A & 3B.
4. Mount bottom mounting bracket.
5. Hook top rain flashing, attached to front - right of supply flange for shipping, under back bend of top.



WARNING

Failure to provide the 1/4 inch clearance between the supply duct and a combustible surface for the first 3 feet of duct can result in fire causing damage, injury or death.

6. Position unit in opening and secure with 5/16 lag bolts; use 7/8 inch diameter flat washers on the lag bolts.
7. Secure rain flashing to wall and caulk across entire length of top. See Figures 3A & 3B.
8. For additional mounting rigidity, the return air and supply air frames or collars can be drilled and screwed or welded to the structural wall itself (depending upon wall construction). Be sure to observe required clearance if combustible wall.
9. On side-by-side installations, maintain a minimum of 20 inches clearance on right side to allow access to control panel and heat strips, and to allow proper airflow to the outdoor coil. Additional clearance may be required to meet local or national codes.

Clearances Required for Service Access and Adequate Condenser Airflow

MODELS	LEFT SIDE	RIGHT SIDE
W3RV1	15"	20"
W3LV1	20"	15"
W5RV1, W6RV1	20"	20"
W5LV1, W6LV1	20"	20"

NOTE: For side by side installation of two (2) W*RV models there must be 20" between units. This can be reduced to 15" by using a W*LV model (left side compressor and controls) for the left unit and W*R (right side compressor and controls) for right unit.

See Specification Sheet.

Minimum Clearances Required to Combustible Materials

MODELS	SUPPLY AIR DUCT FIRST THREE FEET	CABINET
W3R/LV1	1/4"	0"
W5R/LV1	1/4"	0"
W6R/LV1	1/4"	0"

FIGURE 2

Dimensions of Basic Unit for Architectural and Installation Requirements (Nominal)

MODEL	WIDTH (W)	DEPTH (D)	HEIGHT (H)	SUPPLY			RETURN																
				A	B	C	B	E	F	G	I	J	K	L	M	N	O	P	Q	R	S1	S2	T
W3RV1 W3LV1	38.200	17.125	70.563	7.88	27.88	13.88	27.88	40.00	10.88	25.75	17.93	26.75	28.75	29.25	27.00	2.75	39.19	22.75	9.14	4.19	12.00	12.00	5.00
W5RV1 W5LV1	42.075	22.432	84.875	9.88	29.88	15.88	29.88	43.88	13.56	31.66	30.00	32.68	26.94	34.69	32.43	3.37	42.88	23.88	10.00	1.44	16.00	16.00	1.88
W6RV1 W6LV1	42.075	22.432	94.875	9.88	29.88	15.88	29.88	43.88	13.56	41.66	30.00	42.68	36.94	44.69	42.43	3.37	42.88	33.88	10.00	1.44	16.00	21.00	1.88

All dimensions are in inches. Dimensional drawings are not to scale.

**W*RV
RIGHT
UNIT**

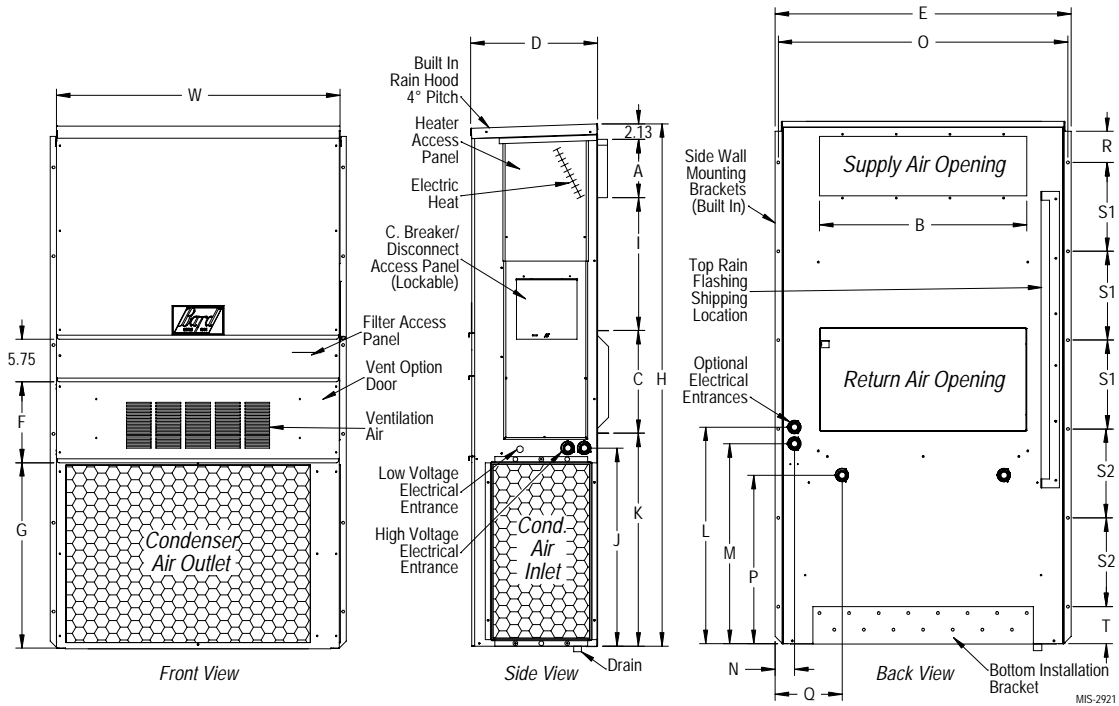

**W*LV
LEFT
UNIT**

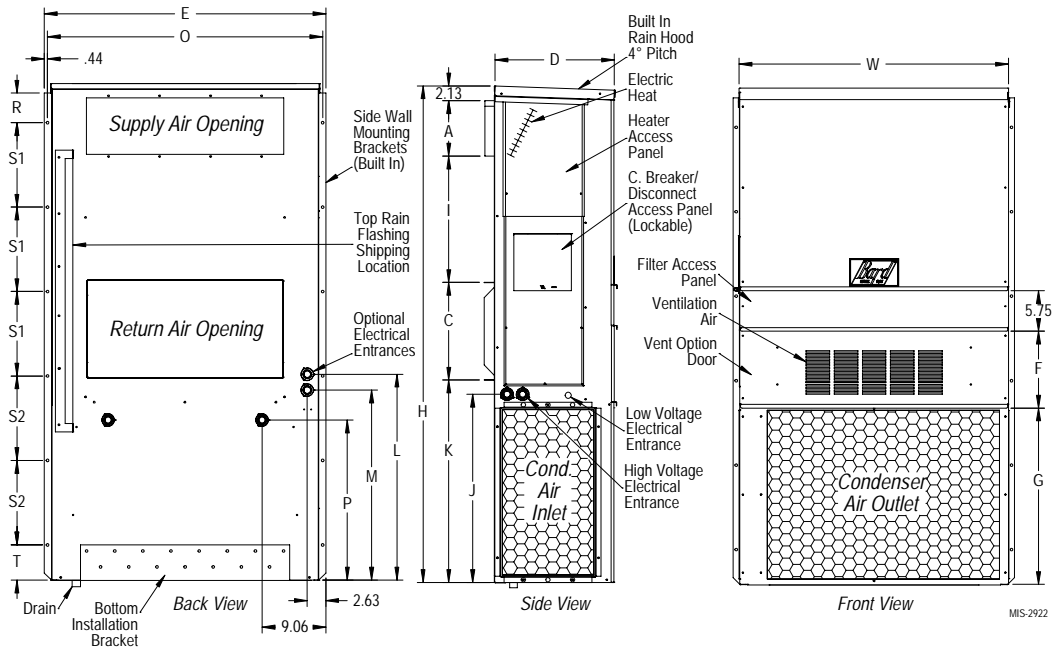
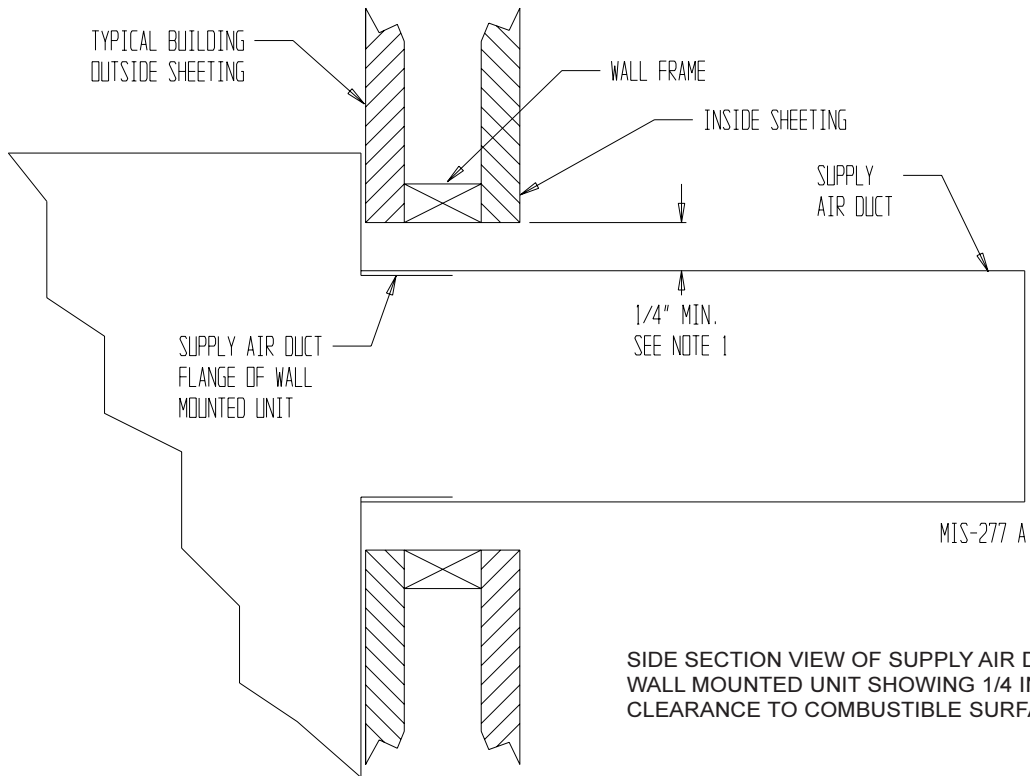

FIGURE 4
ELECTRIC HEAT CLEARANCE
W3RV1, W3LV1, W5RV1, W5LV1, W6RV1, W6LV1



SIDE SECTION VIEW OF SUPPLY AIR DUCT FOR WALL MOUNTED UNIT SHOWING 1/4 INCH CLEARANCE TO COMBUSTIBLE SURFACES.

WARNING

A **minimum** of 1/4 inch clearance must be maintained between the supply air duct and combustible materials. This is required for the first 3 feet of ducting.

It is important to insure that the 1/4 inch minimum spacing is maintained at all points.

Failure to do this could result in overheating the combustible material and may result in a fire causing damage, injury or death.

FIGURE 5 WALL MOUNTING INSTRUCTIONS

SEE FIGURES 3A & 3B – MOUNTING INSTRUCTIONS

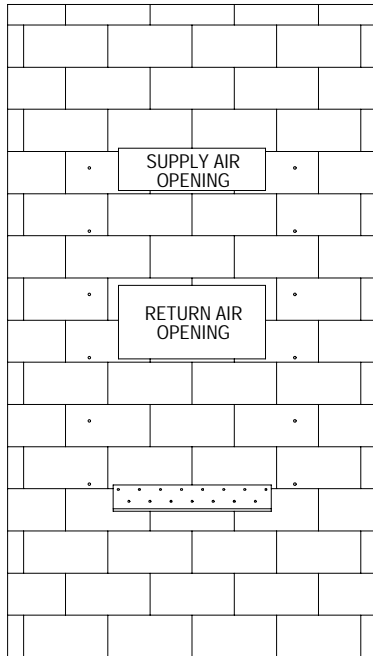

CONCRETE BLOCK WALL INSTALLATION

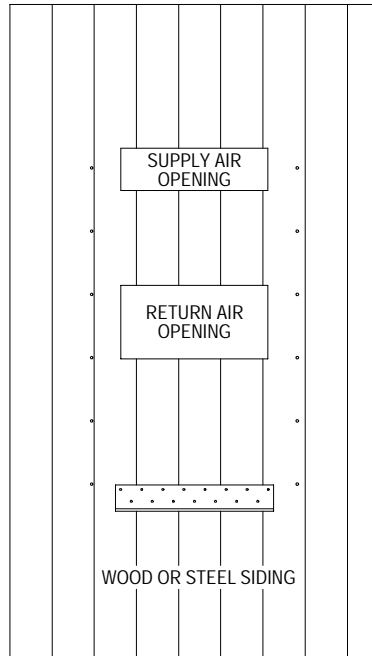

WOOD FRAME WALL INSTALLATION

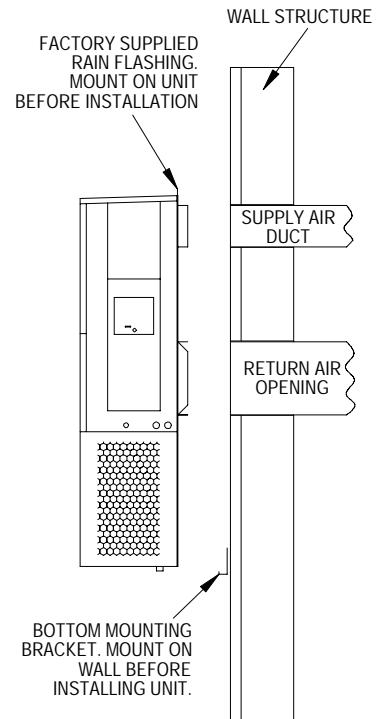

SIDE VIEW

MIS-548 A

FIGURE 6 WALL MOUNTING INSTRUCTIONS

SEE UNIT DIMENSIONS, FIGURE 2,
FOR ACTUAL DIMENSIONS.

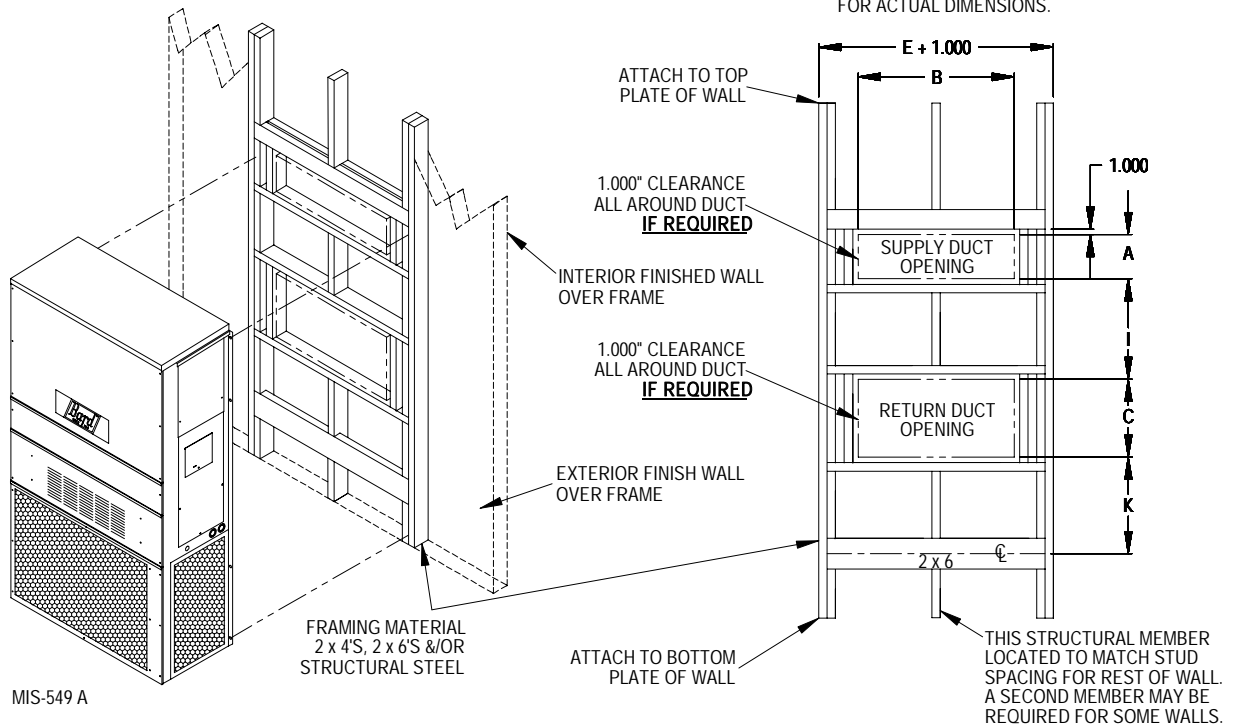

MIS-549 A

**FIGURE 7
COMMON WALL MOUNTING INSTALLATIONS**

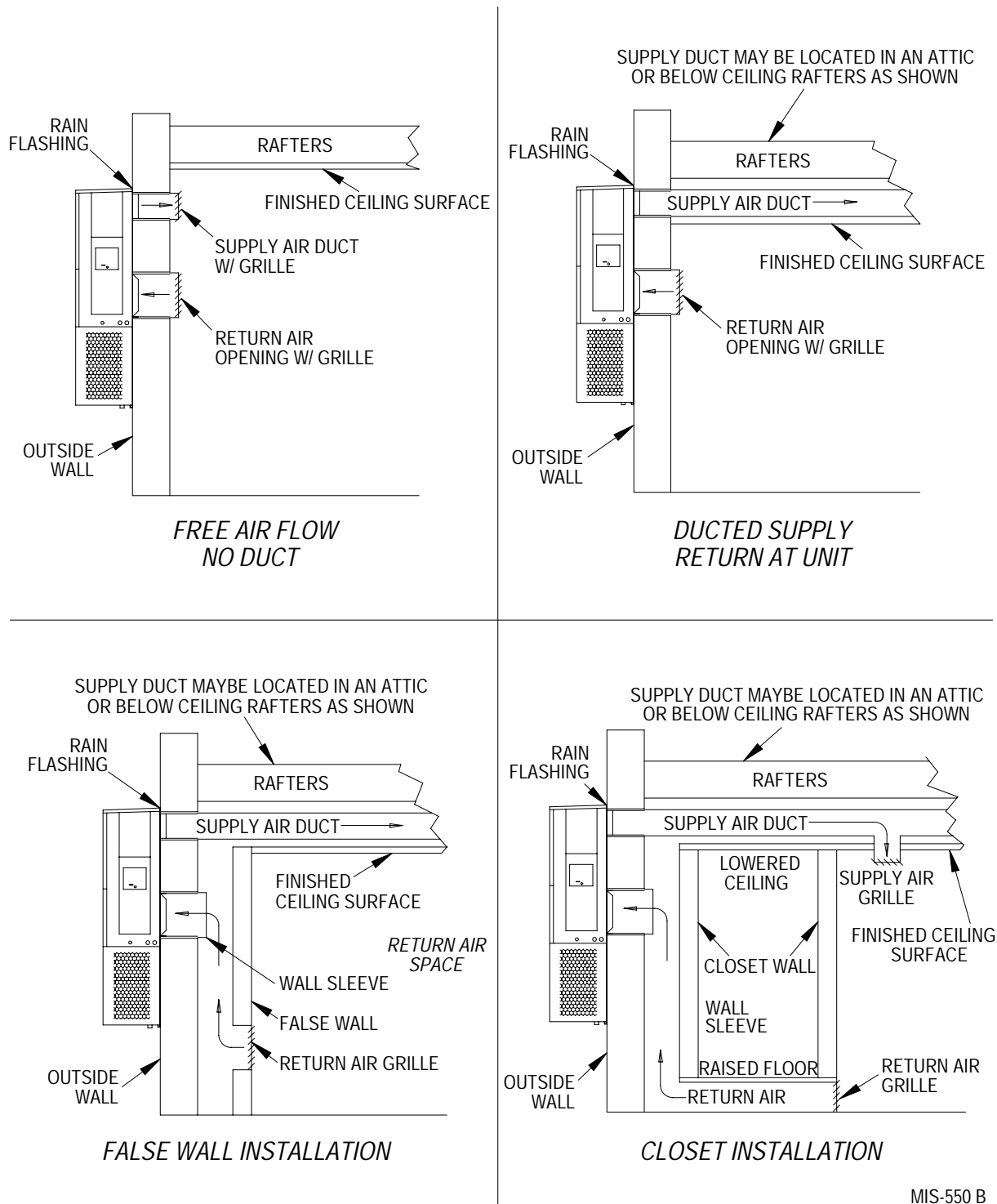

MIS-550 B

WIRING – MAIN POWER

These units are rated for 60/50 Hz operation as follows.

NOTE: This system must be controlled only by the Bard 8403-064 Digital Thermostat/Controller that is supplied with the unit. See below for Wiring and Pages 16-17 for Operating Sequences.

Electrical Code	Volts Hz Phase	Operating Voltage Range
-R	230/208-60-1 220/200-50-1	197 - 253 180 - 242
-S	230/208-60-3 220/200-50-3	197 - 253 180 - 242
-T	460-60-3 400-50-3	414 - 506 360 - 440

Refer to the unit rating plate for wire sizing information and maximum fuse or “HACR” type circuit breaker size. Each outdoor unit is marked with a “Minimum Circuit Ampacity”. This means that the field wiring used must be sized to carry that amount of current.

Depending on the installed KW of electric heat, there may be two field power circuits required. If this is the case, the unit serial plate will so indicate. All models are suitable only for connection with copper wire. Each unit and/or wiring diagram will be marked “Use Copper Conductors Only”. These instructions **must be** adhered to. Refer to the National Electrical Code (NEC) for complete current carrying capacity data on the various insulation grades of wiring material. All wiring must conform to NEC and all local codes.

The electrical data lists fuse and wire sizes (75° C copper) for all models including the most commonly used heater sizes. Also shown are the number of field power circuits required for the various models with heaters.

The unit rating plate lists a “Maximum Time Delay Relay Fuse” or “HACR” type circuit breaker that is to be used with the equipment. The correct size must be used for proper circuit protection and also to assure that there will be no nuisance tripping due to the momentary high starting current of the compressor motor.

The disconnect access door on this unit may be locked to prevent unauthorized access to the disconnect. To convert for the locking capability, bend the tab located in the bottom left-hand corner of the disconnect opening under the disconnect access panel straight out. This tab will now line up with the slot in the door. When shut, a padlock may be placed through the hole in the tab preventing entry.

See “Start Up” section for important information on three phase scroll compressor start ups.

See Table 3 for Electrical Specifications.

WIRING – LOW VOLTAGE WIRING

230/208V, 1 phase and 3 phase equipment dual primary voltage transformers. All equipment leaves the factory wired on 240V tap. For 208V operation, reconnect from

240V to 208V tap. The acceptable operating voltage range for the 240 and 208V taps are:

TAP	RANGE
240	253 – 216
208	220 – 187

NOTE: The voltage should be measured at the field power connection point in the unit and while the unit is operating at full load (maximum amperage operating condition).

DIGITAL THERMOSTAT/CONTROLLER

Terminal	Function	Type	Form
+B	MSTP + (not used)	Communications	
-A	MSTP - (not used)	Communications	
IN4	Outdoor Temperature Sensor	Input	10K OHM Type 3
IN3	Pressure Transducer	Input	0-5 VDC, 0-700 PSIG
GND	Sensor Grounds	Input	
IN2	Lockout Alarm	Input	Relay Closure
24 COM	24VAC Com	Power	
24V	24VAC	Power	
OUT 9	Fan Motor Control	Analog Output	0-10VDC
GND7-9	Control Ground	Analog Output	
OUT 8	Unloader Solenoid Control	Analog Output	0 or 5VDC PWM
OUT 7	Blower Motor Control	Analog Output	0-10VDC
RLY 4	Heater Contactor #1	Relay Output	Relay
SC 4-6	24VAC to Relay Outputs 4-6	Power	
RLY 5	Heater Contactor #2	Relay Output	Relay
RLY 6	(not used)		
RLY 3	(not used)		
SC1-3	24VAC to Relay Outputs 1-3	Power	
RLY 2	Compressor Contactor	Relay Output	Relay
RLY 1	(not used)		

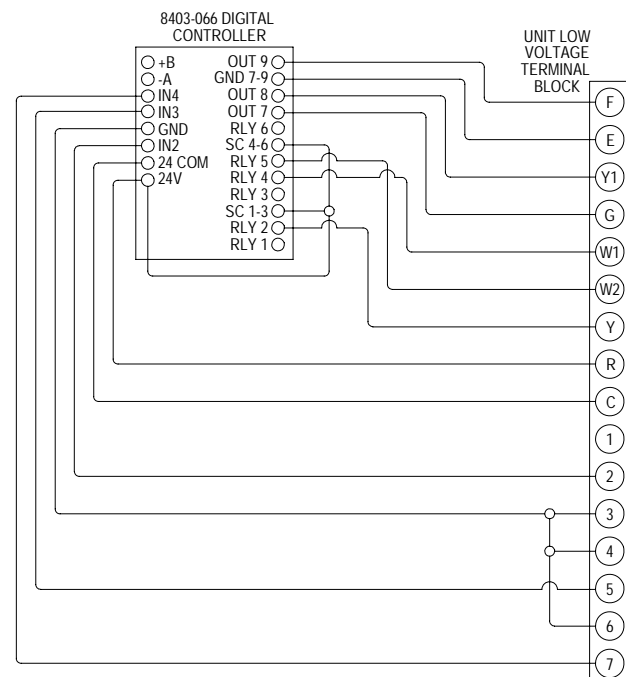

MIS-2852 C

START UP

THESE UNITS REQUIRE R-410A REFRIGERANT AND POLYOL ESTER OIL.

GENERAL:

1. Use separate service equipment to avoid cross contamination of oil and refrigerants.
2. Use recovery equipment rated for R-410A refrigerant.
3. Use manifold gauges rated for R-410A (800 psi/250 psi low).
4. R-410A is a binary blend of HFC-32 and HFC-125.
5. R-410A is nearly azeotropic - similar to R-22 and R-12. Although nearly azeotropic, charge with liquid refrigerant.
6. R-410A operates at 40-70% higher pressure than R-22, and systems designed for R-22 cannot withstand this higher pressure.
7. R-410A has an ozone depletion potential of zero, but must be reclaimed due to its global warming potential.
8. R-410A compressors use polyolester oil.
9. Polyol Ester oil is hygroscopic; it will rapidly absorb moisture and strongly hold this moisture in the oil.
10. A liquid line dryer must be used - even a deep vacuum will not separate moisture from the oil.
11. Limit atmospheric exposure to 15 minutes.
12. If compressor removal is necessary, always plug compressor immediately after removal. Purge with small amount of nitrogen when inserting plugs.

TOPPING OFF SYSTEM CHARGE

If a leak has occurred in the system, Bard Manufacturing recommends reclaiming, evacuating (see criteria above), and charging to the nameplate charge. If done correctly, topping off the system charge can be done without problems.

With R-410A, there are no significant changes in the refrigerant composition during multiple leaks and recharges. R-410A refrigerant is close to being an azeotropic blend (it behaves like a pure compound or single component refrigerant). The remaining refrigerant charge, in the system, may be used after leaks have occurred and then “top-off” the charge by utilizing the pressure charts on the inner control panel cover as a guideline.

REMEMBER: When adding R-410A refrigerant, it must come out of the charging cylinder/tank as a liquid to avoid any fractionation, and to insure optimal system performance. Refer to instructions for the cylinder that is being utilized for proper method of liquid extraction.



WARNING

Failure to conform to these practices could lead to damage, injury or death.

SAFETY PRACTICES:

1. Never mix R-410A with other refrigerants.
2. Use gloves and safety glasses, Polyol Ester oils can be irritating to the skin, and liquid refrigerant will freeze the skin.
3. Never use air and R-410A to leak check; the mixture may become flammable.
4. Do not inhale R-410A – the vapor attacks the nervous system, creating dizziness, loss of coordination and slurred speech. Cardiac irregularities, unconsciousness and ultimate death can result from breathing this concentration.
5. Do not burn R-410A. This decomposition produces hazardous vapors. Evacuate the area if exposed.
6. Use only cylinders rated DOT4BA/4BW 400.
7. Never fill cylinders over 80% of total capacity.
8. Store cylinders in a cool area, out of direct sunlight.
9. Never heat cylinders above 125°F.
10. Never trap liquid R-410A in manifold sets, gauge lines or cylinders. R-410A expands significantly at warmer temperatures. Once a cylinder or line is full of liquid, any further rise in temperature will cause it to burst.

START UP (Continued)

IMPORTANT INSTALLER NOTE

For improved start up performance wash the indoor coil with a dish washing detergent.

HIGH PRESSURE SWITCH

All W*R/LV wall mounted air conditioner series models are supplied with a remote reset for the high and low pressure switch. If tripped, this pressure switch may be reset by turning the thermostat off then back on again.

THREE PHASE SCROLL COMPRESSOR START UP INFORMATION

Scroll compressors, like several other types of compressors, will only compress in one rotational direction. Direction of rotation is not an issue with single phase compressors since they will always start and run in the proper direction.

However, three phase compressors will rotate in either direction depending upon phasing of the power. Since there is a 50-50 chance of connecting power in such a way as to cause rotation in the reverse direction, verification of proper rotation must be made. Verification of proper rotation direction is made by observing that suction pressure drops and discharge pressure rises when the compressor is energized. Reverse rotation also results in an elevated sound level over that with correct rotation, as well as substantially reduced current draw compared to tabulated values.

Verification of *proper rotation* must be made at the time the equipment is put into service. If improper rotation is corrected at this time, there will be no negative impact on the durability of the compressor. However, reverse operation for over one hour may have a negative impact on the bearing due to oil pump out.

NOTE: If compressor is allowed to run in reverse rotation for several minutes, the compressor's internal protector will trip.

All three phase compressors are wired identically internally. As a result, once the correct phasing is determined for a specific system or installation, connecting properly phased power leads to the same Fusite terminal should maintain proper rotation direction.

The direction of rotation of the compressor may be changed by reversing any two line connections to the unit.

PHASE MONITOR

All units with three phase scroll compressors are equipped with a 3 phase 60/50 Hz line monitor to prevent compressor damage due to phase reversal. No changes required for 60 or 50 Hz operation.

The phase monitor in this unit is equipped with two LEDs. If the Y signal is present at the phase monitor and phases are correct the green LED will light.

If phases are reversed, the red fault LED will be lit and compressor operation is inhibited.

If a fault condition occurs, reverse two of the supply leads to the unit. ***Do not reverse any of the unit factory wires as damage may occur.***

SERVICE HINTS

1. Caution owner/operator to maintain clean air filters at all times. Also, not to needlessly close off supply and return air registers. This reduces airflow through the system, which shortens equipment service life as well as increasing operating costs.
2. Check all power fuses or circuit breakers to be sure they are the correct rating.
3. Periodic cleaning of the outdoor coil to permit full and unrestricted airflow circulation is essential.

DIGITAL CONTROLLER

The W3R/LV1 through W6R/LV1 variable capacity air conditioners utilize dedicated controllers and components to optimize this unit for cooling operation from -40 degrees F up to 131 degrees F (-40 degrees C to +55 degrees C). These units are dual rated for 200-240V operation on both 50 and 60 Hz. Please read the following sequence of operation before attempting any troubleshooting or repair. Troubleshooting & repair procedures will be outlined below & later in this Manual.

These models use a digital compressor and variable speed indoor and outdoor motors. The motors and compressor must be replaced with the exact same component to maintain the above stated temperature and voltage ranges of operation. The units are controlled by a Bard digital thermostat/controller. This thermostat/controller contains proprietary programming and must be replaced with the exact same component to ensure proper operation.

See Controller Quick Start Manual 2100-559 and Controller Advanced Programming Manual 2100-560 for complete details.

SEQUENCE OF OPERATION

MODES OF OPERATION

Cool Only Mode:

- Compressor will modulate from 100% down to 20%.
- Compressor will cycle off if thermostat/controller set-point is reached.

Heat Only Mode:

- Electric heat Stage 1 operates at 1st-stage heating set-point.
- Electric heat Stage 2 (if equipped) operates on 2nd stage (-2F below heating set-point).

Auto Mode:

- Cooling or heating automatically selected based on building temperature vs. thermostat/controller set-points and operates as described above.

CCVC (Continuous Compressor Variable Capacity):

- Compressor will modulate from 100% down to 20%.
- Compressor will not cycle off if thermostat/controller set-point is reached, and would stay running at the 20% minimum capacity.
- If space temperature drops -2F below cooling set-point electric heat Stage 1 will then cycle to maintain that condition.
- If Stage 2 electric heat is installed, and if required, will cycle at -4F below cooling set-point to maintain that condition.
- If CCVC is terminated the controller will revert to Cool or Auto operation.
- CCVC would be an Operating Mode for all applications where continuous run of the compressor is a requirement.

Testing & Troubleshooting Mode CCFC (Continuous Compressor Fixed Capacity):

- This unit must be controlled with the digital thermostat controller supplied with the unit. To test or troubleshoot, change system mode to CCFC. This will ensure unit runs continuously and in full capacity mode. AHRI ratings are based on this mode of operation.

CCFC (Continuous Compressor Fixed Capacity):

- The compressor is turned ON and locked ON as long as the thermostat/controller is in Test Mode 2.
- When in CCFC the compressor does not modulate but will be locked ON at 100% capacity.
- If space temperature drops -2F below cooling set-point electric heat Stage 1 will then cycle to maintain that condition.
- If Stage 2 electric heat is installed, and if required, will cycle at -4F below cooling set-point to maintain that condition.
- If CCFC is terminated the controller will revert to Cool or Auto operation.
- CCFC would not be considered an Operating Mode and should only be used for system testing as required.

Indoor Blower Operation

The indoor blower speed will modulate with the compressor operation from 50% to 100% of operation. Once compressor operation is at 50 or below, percent airflow will be at 50% and no further reduction of

airflow will occur. Modulation is accomplished by modulating a 0-10 volt signal from OUT 7 to the indoor blower control board which then sends a PWM signal to the indoor blower motor.

An additional option to maintain airflow at 100% is also available. This selection is done at the thermostat/controller under Fan Modes. Default is No for "Always 100%" setting. Change to Yes to disable indoor blower modulation as described above.

2 LED's are located on the Blower Control Board. The Red LED will light anytime 24V is applied to the board and it is connected to the ECM motor. The Green LED will flash a series of short and long flashes depending on the output from the digital thermostat/controller.

Outdoor Fan Motor Operation

The outdoor fan motor speed is varied in response to outdoor air temperature and pressure. The fan motor will cycle on and off with the compressor when not in a CCVC or CCFC. At all times above 122 degrees OAT, the outdoor fan, OUT 9, will be energized at high speed. From 122 degrees to 55 degrees the outdoor fan, OUT 9, will be set at normal outdoor airflow. Below 55 degrees the outdoor fan will modulate to maintain a 300 psi head pressure. This will act as a low ambient fan cycling control. The output may go to zero output to maintain the 300 PSI. The outdoor ECM motor will be programmed with a minimum RPM allowed to protect the bearing system. Any signal that is less than the percent torque required to maintain the minimum RPM will cause the motor to shut off. Once head pressure rises the motor will restart.

These functions are regulated by the digital thermostat/controller with input from the pressure transducer and output signal to the Fan Control Board.

2 LED's are located on the outdoor Fan Control Board. The Red LED is not active and does not light under any condition. The Green LED will flash a series of short and long flashes depending on the output from the digital thermostat/controller.

Capacity Modulation and High Head Pressure Control

The pressure transducer monitors the high side pressure providing input to the digital thermostat/controller. It is powered using a 5Vdc power supply with a digital relay signaling the compressor unloader solenoid as required. When the ECU head pressure exceeds 615 PSI based on outdoor and indoor ambient conditions the compressor will automatically start to reduce capacity to stay on-line keeping the pressure at or below 575 PSI. The thermostat/controller display alternates between OD temperature and discharge pressure. When compressor capacity is being reduced due to high pressure conditions it will also indicate "High Head Pressure Control" mode on the display. A separate 650 PSI high pressure cutout switch is also employed as additional safety device. See Compressor Control Module on following page for more details.

COOLING SEQUENCE

Compressor Operation

The cooling capacity of the WV series is controlled by loading or unloading the compressor. On a call for cooling, the unloader solenoid is energized for one second to ensure pressure equalization in the compressor. The compressor contactor, RLY 2, is then energized and the compressor will start. A PI control loop then calculates the compressor capacity needed to reach set point and modulates the compressor. Modulation range is from 20% to 100% capacity. Modulation is accomplished by a pulse width modulated signal from OUT 8 which energizes the solid state relay (SSR) and energizes or de-energizes the unloader solenoid. The required compressor capacity is calculated every 15 seconds.

20% load means 0 VDC for 3.0 seconds and 5 VDC for 12.0 seconds from OUT 8.

30% load means 0 VDC for 4.5 seconds and 5 VDC for 10.5 seconds from OUT 8.

40% load means 0 VDC for 6.0 seconds and 5 VDC for 9.0 seconds from OUT 8.

50% load means 0 VDC for 7.5 seconds and 5 VDC for 7.5 seconds from OUT 8.

60% load means 0 VDC for 9.0 seconds and 5 VDC for 6.0 seconds from OUT 8.

70% load means 0 VDC for 10.5 seconds and 5 VDC for 4.5 seconds from OUT 8.

80% load means 0 VDC for 12.0 seconds and 5 VDC for 3.0 seconds from OUT 8.

90% load means 0 VDC for 13.5 seconds and 5 VDC for 1.5 seconds from OUT 8.

100% load means 0 VDC for 15 seconds and 5 VDC for 0.0 seconds from OUT 8.

Outdoor Temperature Sensor

A sensor probe projects out the bottom of the ECU control box into the outdoor section, and this provides input for the outdoor fan sequences below 55F and above 115F described under Outdoor Fan Motor Operation.

Discharge Temperature Sensor

This sensor is mounted on the compressor discharge line and protects the compressor against overheating. It opens at 250F and closes at 200F.

HEATING SEQUENCE

On a call for heating, if the space temperature falls 1°F below setpoint, the first stage of heating, RLY 4, will cycle ON. If the space temperature falls 3°F below setpoint, the second stage of heating, RLY 5, will cycle ON. Indoor Blower airflow is maintained at the Rated unit airflow at all times during heating.

Control Device	Normal	Abnormal
Indoor Motor Blower Control Board	Red LED lit, Green LED flashes long and short flashes when Fan is called for, 2-10Vdc from Signal to Common. Jumper is on P.	No Red LED, and no Green flashes when 2-10Vdc is present from Signal to Common. Jumper is on P.
Outdoor Motor Fan Control Board	Red LED not lit. Green long and short flashes when 2-10Vdc present from Signal to Common on board. Jumper is on P.	Red LED lit, and no Green flashes when 2-10Vdc is present from Signal to Common. Jumper is on P.
5Vdc Power Supply	Red LED lit when 24Vac present. 5Vdc present at solid Red and solid Black wires. Both jumpers on Half. 3A 250V fuse.	Red LED not lit. 5Vdc not present at solid Red and solid Black wires. Both jumpers on Half. Check 3A fuse.

LEAD/LAG SEQUENCE

The digital controllers can be used for dual units used in a redundant application by using the scheduling function as follows:

1. The controllers should be mounted side by side so that they are in the same temperature zone.
2. The time setting on both controllers need to be synchronized to the same time of day. NOTE: there is a 72-hour time retention if power is removed. If power off-time exceeds 72 hours, the time clock in each device must be reset to match. The exact time is not important as long as both controllers are set the same unless it is critical to control the time of day when the units swap operating positions.
3. Set one controller #1 to be Occupied for a 12-hour period and Unoccupied for the other 12-hour period. Set controller #2 so that it is exactly the opposite. Unoccupied for the 12-hour period when #1 is Occupied and Occupied when #1 is Unoccupied.
4. Set Occupied cooling setpoint the same for each controller, and Unoccupied the same for each. 4°F difference is suggested.
5. Set controllers to "Auto" mode of operation.

Example:

1. Both Unit #1 and #2 have Occupied setpoint of 74°F and Unoccupied setpoint of 78°F
2. Unit #1 set for Occupied from 1:00 a.m. to 1:00 p.m. & Unoccupied from 1:00 p.m. to 1:00 a.m.
3. Unit #2 set for Unoccupied from 1:00 a.m. to 1:00 p.m. & Occupied from 1:00 p.m. to 1:00 a.m.
4. Every 12 hours the units will swap position as being the lead unit, and the lag unit is available for back up operation at the higher temperature should the situation ever arise.

COMPRESSOR CONTROL MODULE

The compressor control module is standard on all models covered by this manual. The compressor control module is an anti-short cycle/lockout timer with high and low pressure switch monitoring and alarm relay output.

Adjustable Delay On Make And Break Timer

On initial power up or anytime power is interrupted to the unit, the *delay on make* period begins, which will be 2 minutes plus 10% of the *delay on break* setting. When the delay on make is complete and the high pressure switch and low pressure switch is closed, the compressor contactor is energized. Upon shutdown, the delay on break timer starts and prevents restart until the delay on break and delay on make periods have expired.

During routine operation of the unit with no power interruptions, the compressor will operate on demand with no delay.

High Pressure Switch and Lockout Sequence

If the high pressure switch opens, the compressor contactor will de-energize immediately. The lockout timer will go into a *soft lockout* and stay in soft lockout until the high pressure switch closes and the delay on break time has expired. If the high pressure switch opens again in this same operating cycle, the unit will go into *manual lockout* condition and the alarm relay circuit will energize. Recycling the wall thermostat resets the manual lockout.

Low Pressure Switch, Bypass, and Lockout Sequence

If the low pressure switch opens for more than 120 seconds, the compressor contactor will de-energize and go into a soft lockout. Regardless the state of the low pressure switch, the contactor will reenergize after the delay on make time delay has expired. If the low pressure switch remains open, or opens again for longer than 120 seconds, the unit will go into manual lockout condition and the alarm relay circuit will energize. Recycling the wall thermostat resets the manual lockout.

Alarm Relay Output

Alarm terminal is output connection for applications where alarm relay is employed. This terminal is powered whenever the compressor is locked out due to HPC or LPC sequences as described.

NOTE: Both high and low pressure switch controls are inherently automatic reset devices. The high pressure switch and low pressure switch cut out and cut in settings are fixed by specific air conditioner unit model. The lockout features, both soft and manual, are a function of the Compressor Control Module.

ADJUSTMENTS

Adjustable Delay on Make and Delay on Break Timer

The potentiometer is used to select Delay on Break time from 30 seconds to 5 minutes. Delay on Make (DOM) timing on power-up and after power interruptions is equal to 2 minutes plus 10% of Delay on Break (DOB) setting:

0.5 minute (30 seconds)	DOB = 123 second	DOM
1.0 minute (60 seconds)	DOB = 126 second	DOM
2.0 minute (120 seconds)	DOB = 132 second	DOM
3.0 minute (180 seconds)	DOB = 138 second	DOM
4.0 minute (240 seconds)	DOB = 144 second	DOM
5.0 minute (300 seconds)	DOB = 150 second	DOM

During routine operation of the unit with no power interruptions the compressor will operate on demand with no delay.

Typical Settings for Dual Unit Installation:

Unit 1: DOB set at 2 minutes, and DOM is 132 seconds

Unit 2: DOB set at 4 minutes, and DOM is 144 seconds

PRESSURE SERVICE PORTS

High and low pressure service ports are installed on all units so that the system operating pressures can be observed. A pressure table can be found later in the manual covering all models. It is imperative to match the correct pressure table to the unit by model number. See Table 2.

TROUBLESHOOTING

FAN BLADE SETTING DIMENSIONS

Shown in Figure 8 is the correct fan blade setting for proper air delivery across the outdoor coil. Refer to Table 1 for unit specific dimension.

Any service work requiring removal or adjustment in the fan and/or motor area will require that the dimensions below be checked and blade adjusted in or out on the motor shaft accordingly.

**FIGURE 8
FAN BLADE SETTING**

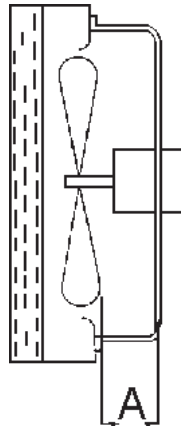

MIS-1724

**TABLE 1
FAN BLADE DIMENSION**

Model	Dimension A
W3RV1 W3LV1	1.25"
W5RV1 W5LV1	1.75"
W6RV1 W6LV1	1.75"

REMOVAL OF FAN SHROUD

1. Disconnect all power to the unit.
2. Remove the screws holding both grilles, one on each side of unit, and remove grilles.
3. Unwire condenser fan motor.
4. Remove the bolts and nuts holding the condenser fan motor bracket to the fan shroud.
5. Slide the condenser fan motor and bracket to the rear of the condenser section.
6. Remove screws holding fan shroud to condenser and bottom support plate.
7. Slide fan shroud out the left side of the unit.
8. Reverse steps to install.

R-410A

REFRIGERANT CHARGE

This unit was charged at the factory with the quantity of refrigerant listed on the serial plate. AHRI capacity and efficiency ratings were determined by testing with this refrigerant charge quantity.

The following pressure tables show nominal pressures for the units. Since many installation specific situations can affect the pressure readings, this information should only be used by certified technicians as a guide for evaluating proper system performance. They shall not be used to adjust charge. If charge is in doubt, reclaim, evacuate and recharge the unit to the serial plate charge.

**TABLE 2
COOLING PRESSURE TABLE**

Air Temperature Entering Outdoor Coil °F (°C)

Model	D.B/W.B. ①	Pressure	75 (23.9)	80 (26.7)	85 (29.4)	90 (32.2)	95 (35.0)	100 (37.8)	105 (40.6)	110 (43.3)	115 (46.1)	120 (48.9)	125 (51.7)	131 (55.0)
W3RV W3LV	75 / 62F (23.9/16.7C)	Low Side	128	127	127	127	128	129	130	132	135	See Note ②		
		High Side	355	373	394	416	442	469	498	530	565			
	80 / 67F (26.7/19.4C)	Low Side	137	136	136	136	139	139	139	141	144			
		High Side	364	383	404	427	444	481	511	544	579			
	85 / 72 (29.4/22.2C)	Low Side	142	141	141	141	142	143	144	146	149			
		High Side	377	396	418	442	469	498	529	563	599			
W5RV W5LV	75 / 62F (23.9/16.7C)	Low Side	125	128	130	132	134	136	137	137	138			
		High Side	336	358	380	403	427	451	478	504	531			
	80 / 67F (26.7/19.4C)	Low Side	134	137	139	141	143	145	146	147	148			
		High Side	345	367	390	413	438	463	490	517	545			
	85 / 72 (29.4/22.2C)	Low Side	139	142	144	146	148	150	151	152	153			
		High Side	357	380	404	427	453	479	507	535	564			
W6RV W6LV	75 / 62F (23.9/16.7C)	Low Side	113	113	114	115	117	118	120	122	124			
		High Side	344	361	381	404	430	459	490	526	564			
	80 / 67F (26.7/19.4C)	Low Side	121	121	122	123	125	126	128	130	133			
		High Side	353	370	391	414	441	471	503	539	578			
	85 / 72 (29.4/22.2C)	Low Side	125	125	126	127	129	130	132	135	138			
		High Side	365	383	405	428	456	487	521	558	598			

Low side pressure ± 4 PSIG
High side pressure ± 10 PSIG

Tables are based upon rated CFM (airflow) across the evaporator coil. If there is any doubt as to correct operating charge being in the system, the charge should be removed, system evacuated and recharged to serial plate charge weight.

NOTE ①: Return air temperature at 50% R.H.

NOTE ②: Units rated to 131F (55C) outdoor temperature, but higher fan speeds and automatic modulation of the compressor due to pressure control make pressure readings above 115°F very unstable. Pressure table is based on low speed condenser fan operation. Fan speed increases above 115°F. Check pressures on unit at outdoor ambient below 115°F. Set thermostat at least 3° below current room temperature to ensure 100% comp operation for purpose of pressure testing.

**TABLE 4
RECOMMENDED AIRFLOW**

Model	Rated CFM *	Rated ESP *	Recommended Airflow Range
W3R/LV	1100	.15	1100 - 550
W5R/LV	1700	.20	1700 - 850
W6R/LV	1700	.20	1700 - 850

* Rated CFM and ESP on high speed tap.

**TABLE 5
MAXIMUM ESP OF OPERATION
ELECTRIC HEAT ONLY**

Model	W3	W5, W6
	FRONT	FRONT
	High	High
-A0Z	.50	.50
-A05	.50	.50
-A10	.50	.50
-B0Z	.50	.50
-B06	.50	.50
-B09	.50	.50
-C0Z	.50	.50
-C09	.50	.50
-C12	.45	.50

Values shown are for units equipped with standard 1-inch throwaway filter or 1-inch washable filter. Derate ESP by .15 for 2-inch pleated filters.

**TABLE 6
ELECTRIC HEAT**

Models	240V-1		208V-1		240V-3		208V-3		460V-3		
	KW	Amps	BTUH	Amps	BTUH	Amps	BTUH	Amps	BTUH	Amps	BTUH
4		16.7	13650	14.4	10240						
5		20.8	17065	18.1	12800						
6						14.4	20500	12.5	15360	7.2	20500
8		33.3	27300	28.8	20475						
9						21.7	30600	18.7	23030	10.8	30700
10		41.6	34130	36.2	25600						
12										14.4	40950
15		62.5	51250	54.0	38400	36.2	51200	31.2	38400	18.0	51200
18						43.3	61430	37.5	46100		
20		83.2	68260	72.1	51200						

**TABLE 7
VENT & CONTROL OPTIONS**

Part Number	Description	W3R/LV	W5R/LV	W6R/LV
CMC-15	Start Kit (230V 1-Phase)	X	X	
BFAD-3	Barometric Fresh Air Damper - Standard	X		
BOP-3	Blank Off Plate	X		
BFAD-5	Barometric Fresh Air Damper - Standard		X	X
BOP-5	Blank Off Plate		X	X

Free Manuals Download Website

<http://myh66.com>

<http://usermanuals.us>

<http://www.somanuals.com>

<http://www.4manuals.cc>

<http://www.manual-lib.com>

<http://www.404manual.com>

<http://www.luxmanual.com>

<http://aubethermostatmanual.com>

Golf course search by state

<http://golfingnear.com>

Email search by domain

<http://emailbydomain.com>

Auto manuals search

<http://auto.somanuals.com>

TV manuals search

<http://tv.somanuals.com>