



X-COUNTRY SERIES

Cougar

CX



OWNER'S MANUAL / GUIDE D'UTILISATION



CONGRATULATIONS AND THANK YOU FOR PURCHASING A CHARIOT CARRIER!



Congratulations on choosing a X-Country series CTS Ready Chassis, the key component of the world's premiere **Child Transport System (CTS)**. Your new CTS carrier offers superior quality, safety features, and comfort. In addition, Chariot's CTS Conversion Kits can provide you with the versatility to meet all of your child transportation needs.

The CTS Conversion Kits available from your Chariot dealer are the following: **1.** Jogging CTS Kit **2.** Cycling CTS Kit **3.** Strolling CTS Kit (wheels only) **4.** Hiking CTS Kit **5.** X-Country Skiing CTS Kit

IMPORTANT

Read all instructions before using your Chariot Carrier.

TABLE OF CONTENTS

General Warnings2
 Carrier Maintenance, Care and Storage2
 Safety Guidelines3
Chariot Carrier CTS Ready Chassis Assembly
 1.0 Folding and Unfolding the Carrier4
 1.1 Wheel Assembly4
 1.2 Handlebar Instructions5
 1.3 Weather Cover Features5
 1.4 Suspension Adjustments6
 1.5 Side Window Removal (CX carriers)6
 1.6 Rear Storage Compartments6
 1.7 Adjusting the Rear Cargo Bag7
 1.8 Parking Brake Instructions7
 1.9 CX Drum Brakes7-8
 1.8 Child Placement and Seatbelts10
Parts Lists
 Cougar 1, Cougar 211
 CX1, CX212
Strolling CTS Kit (wheels only)
 2.0 Installation13
 2.1 Storage13
Jogging CTS Kit
 3.0 Installation14
 3.1 Storage15
Cycling CTS Kit
WARNINGS15
 4.0 Reflectors and Flag Assembly16
 4.1 Attaching Your New Quick Release (QR) Skewer & Axle Mounted Hitch Cup to Your Bicycle16
 4.2 Attaching Your Axle Mounted Hitch Cup to Your Bicycle if You Have a Solid Axle Style Hub16
 4.3 Hitch Arm Assembly17
 4.4 Attaching Your Carrier to the Hitch Cup on Your Bicycle17
 4.5 Hitch Arm Storage17
 4.6 Pull Wagon17
X-Country Skiing CTS Kit
 5.0 Installation18
 5.1 Shoulder Harness Adjustments18
Hiking CTS Kit
 6.0 Installation19
 6.1 Shoulder Harness Adjustments19
 Accessories20
 Notes20
 French Instruction Manual21
 Limited Lifetime Warranty41

GENERAL WARNINGS

This manual contains many **WARNINGS** and **CAUTIONS**. Read and understand all of the **WARNINGS** and **CAUTIONS**. Failure to assemble and/or use this carrier correctly may lead to serious personal injury or death to you and/or your passengers.

- Do not install a car seat or any other seating device not approved by the manufacturer inside the carrier.
- Make no modifications to the carrier.
- The carrier may become unstable if a parcel bag or rack not approved by the manufacturer is attached to the carrier.
- Do not allow any of the child's body, clothing, shoe laces, or toys to come in contact with moving parts.
- Never leave children unattended in the carrier.
- Failure to comply with the manufacturer's instructions may lead to serious injury or death to you and to your passengers.
- Maximum capacity of the carrier is 75 lb (34 kg) for one child carriers and 100 lb (45 kg) for two child carriers. This includes the weight of the child/children and cargo. Do not use with children who exceed the weight limitations.
- Do not use cleaning solvents on the carrier. Clean only with mild soap and water.
- When used with only one passenger, the passenger should be seated in a center seating position.
- Passengers must always use seat belts.
- Maximum tire pressure is 30 – 35 psi.
- Care must be taken when folding and unfolding to prevent finger entrapment.
- Never use your carrier to go up or down stairs or on steep hills.

When carrier is used in Jogging or Strolling mode, please observe the following:

- Use wrist safety strap at all times.
- Always use parking brake when the carrier is stationary.
- Never in-line skate with your carrier.
- Maximum weight in the rear combined pockets is 2.2 lb (1 kg). The carrier may become unstable if the pocket is overloaded.

When carrier is used in Cycling mode, please observe the following:

- A reflector that complies with CPSC regulations shall be visible on the rear of the trailer and on the side of the wheels.
- Before each ride, ensure the attached carrier does not interfere with braking, pedaling, or steering of the bicycle.
- Never ride a bicycle at night without adequate lighting. Obey all local legal requirements for lighting.
- Ride with extreme caution, never exceed 25 km/h, and slow down to less than 10 km/h around corners and on rough roads.
- Use of a trailer changes the stability, braking requirements and riding characteristics of your bike.
- Always use flag for increased visibility.
- Before the carrier can be used with the Cycling CTS Kit, children must be at least 1 year old and able to sit upright unassisted.
- Passengers must always wear a CPSC or CE approved bicycle helmet.

CARRIER MAINTENANCE, CARE AND STORAGE

- Hitch Maintenance** - Check that the hitch and back up straps are properly secured before every ride. Periodically check the hitch for damage, cracks, etc. Replace at first sign of damage. Any damage/deterioration on any parts of your Chariot carrier should be repaired/replaced immediately to reduce the risk of personal injury.
- Fabric/Shell Care** - Your Chariot Carrier is manufactured from a tough, durable, water resistant fabric. Clean fabric with household soap or mild detergent and warm water only. Wipe dry. Do not machine dry.
- Windows** - Do not use your carrier in temperatures below -20°C (-4°F) . Plastic windows can crack at these low temperatures. If carrier is stored/left out in very cold weather you will need to let it warm up before folding or uprighting.
- Wheels, Axles, and Brakes(for CX carriers)** - Wheels should be serviced by a Chariot Dealer at least twice a year. Check wheels for loose spokes, axles for proper security, and brakes for good functioning every time you use your Chariot carrier.
- Hardware and Fasteners** - Regularly inspect nuts and bolts to ensure they are tightened securely.
- Storage** - Store your carrier in a dry, well-ventilated area. To avoid mildew, make sure carrier is dry before storing. Keep your carrier out of the sun when not in use to reduce fading. Do not store the carrier attached to your bicycle.

Always inspect all parts every time you use your carrier!

SAFETY GUIDELINES

Sixteen important rules for the safe use of your Chariot Carrier.

1. **Read all instructions before use!** Failure to read, understand and follow these instructions may result in an otherwise avoidable accident in which you and/or your passengers could suffer serious injury or death.
2. **The safe and proper use of this product is your responsibility!** Take a practice bicycle ride, walk/run, hike, or cross-country ski with a weighted carrier (weighted greater than your expected load with children and cargo) before using your carrier to ensure you can handle a loaded carrier in each activity. Be extremely careful on hills and try to avoid them if possible. In addition to safe bicycle practices, the rules listed below must be followed at all times.
3. **Make sure your bicycle is in good working condition.** We recommend a frequent safety check of your bike by a certified bicycle mechanic.
4. **Do not modify or alter carrier or bicycle.** Ask your Chariot Dealer if you are not sure whether your bicycle is compatible with your carrier.
5. **When used as a bicycle trailer, children must be at least 1 year old and be able to sit upright alone.** Consult your pediatrician before carrying any child younger than one year.
6. **Do not exceed the maximum carrier load of 75 lb (34 kg) for one child carriers and 100 lb (45 kg) for two child carriers. These capacities include the weight of child/children and cargo.** Articles carried in the carrier should be well anchored to avoid shifting during travel. Unstable loads and overloading make the carrier less stable and more difficult to control.
7. **Always fasten shoulder harness, lap belt and crotch strap securely and tightly around children.** Periodically check placement of shoulder straps, especially for a sleeping child. Make sure children cannot put fingers into the wheel spokes. Instruct children not to bounce, rock or lean.
8. **Do not leave children unattended in the carrier.**
9. **To insure a smooth ride, keep tires inflated to the recommended pressure shown on the tire side wall. Check tire pressure before each use.** Over inflating tires or use of high pressure tires can cause the carrier to overturn.
10. **Use this carrier only with non-motorized bicycles capable of supporting the additional load of the carrier and child.** Do not use your carrier on electric bicycles, motorcycles, mopeds, automobiles or any other motor vehicle. Check the information supplied with your bike to verify compatibility or ask your dealer.
11. **Do not use a kickstand or other parking device to support the bicycle with a trailer attached.** Attaching a trailer can change the balance of the bicycle making kickstands ineffective. The bicycle can fall over, damaging it and the trailer.
12. **Always use the high visibility flag supplied with the trailer.** Do not assume you have the right-of-way. Do not pull your trailer in high traffic areas such as busy streets, highways or anyplace it may be unsafe to ride with children.
13. **Always verify that the folding brackets are secure and hold the carrier in an upright position.**
14. **Avoid riding at night.** Your ability to see and be seen is greatly reduced. If you must ride at night, use proper lighting and reflectors on your bicycle and wear bright reflective clothing
15. **Both cyclist and children must wear approved bicycle helmets.** If your child is too small to properly wear the smallest size approved helmet, they should not ride in the carrier.
16. **Always obey all traffic laws, and use proper hand signals.**

WARNING!

Bicycle trailers can tip over causing serious injury to passenger(s) and/or rider.

Hitting an obstacle with a wheel may cause the trailer to tip over at any speed!



CHARIOT CARRIER CTS READY CHASSIS ASSEMBLY

Your Chariot Carrier is shipped 99% assembled. Initial assembly takes a few minutes. After that, folding and unfolding can be done in seconds.



1.0 Folding and Unfolding the Carrier

NOTE: Any reference to orientation (left or right) is from the passenger's point of view while in the carrier.



Stand at the back of the carrier body. Grab the upper frame and pull up until it stops.

CAUTION: Pull back on the lower bars from under the pivot brackets to avoid pinching your fingers.



Pull back on both the right and left lower backtube bars until they "snap" all the way back over center and the auto-lock disks engage.

WARNING: Ensure that folding brackets are correctly locked before using carrier. Failure to do so could cause the carrier to collapse.

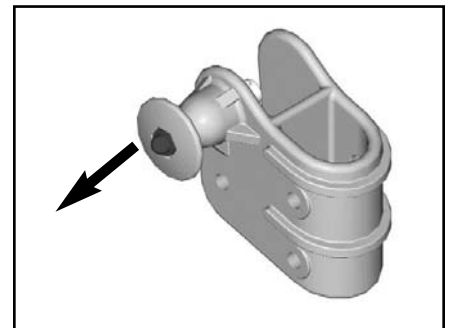

To collapse the carrier, pull the release disks and then push both the right and left lower backtube bars forward until the carrier is completely collapsed.

CAUTION: Do not attempt to collapse carrier without first pulling the release disks.

1.1 Wheel Assembly

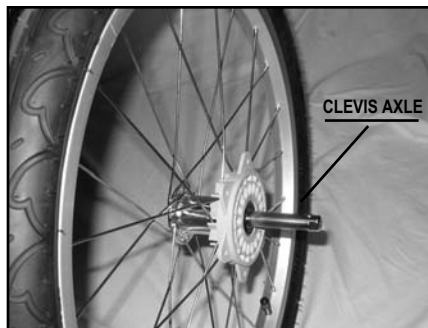

1. Depress the rubber cap on the wheel hub with your thumb and fully insert the clevis axle into the hollow axle. CX carriers have the brake located at the end of the axle, with the hollow axle located in the centre of the brake. Once fully inserted and secured, you should hear a "click" sound. **Important:** To ensure the axle system is engaged properly, test by trying to pull the wheel outwards after installing. The wheel should be locked in its installed position. If not, do not use and take your carrier to your Chariot Dealer for servicing. 2. Repeat all steps for the other wheel.

1.2 Handlebar Instructions

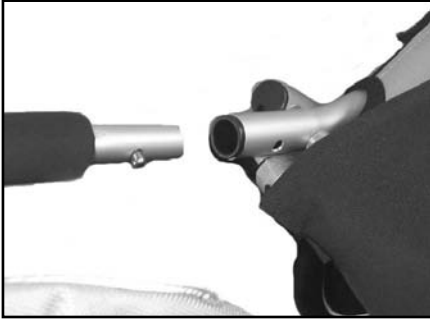

Insert both ends of the handlebar into the aluminum sleeves located at the upper rear section of the carrier.

WARNING: Failure to properly install the handlebars or use the wrist safety strap could cause the carrier to become separated from you resulting in serious injury.

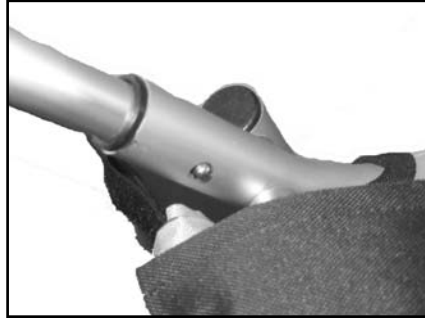

Depress both spring buttons and insert the handlebars fully into the sleeves. **Both spring buttons must "pop" out of the holes located on the inner side of the sleeves to secure the handlebar in place.**

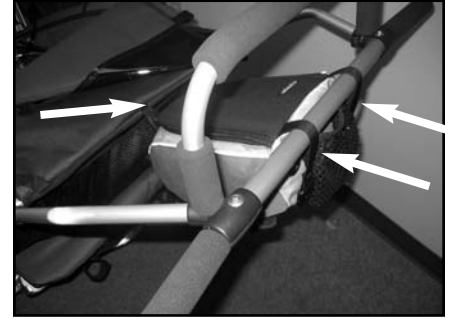

(CX model only)

Secure the front of the handlebar bag to the clip on the back of the carrier's cover. Wrap the two web strap on the back of the bag around the carrier's handlebar and secure them using the clips.

CAUTION Do not place more than 0.5kg/1 lb in the handlebar bag, when used on the carrier. Overloading this bag can cause the carrier to tip.

1.3 Weather Cover Features



Attach the loops from the back corner of the weather cover over the aluminum sleeves located at the upper rear section of the carrier.

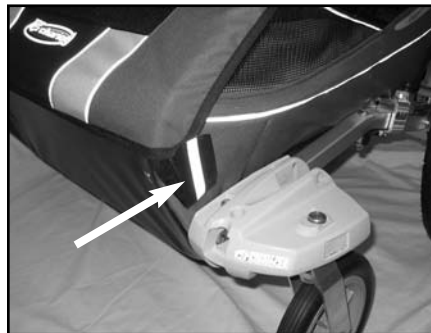

Fasten the front corners of the weather cover to the Velcro tabs located on the front lower corners of the frame.

Note: Your Chariot Carrier has climate control features designed to regulate your child's temperature. Periodically monitor your child to ensure that he/she is comfortable in terms of temperature.

WARNING: Failure to use the weather cover could expose your child to flying rocks, insects, and other debris.

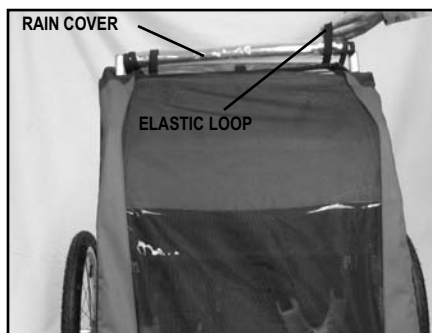

During cooler temperatures use the rain cover to keep your child warmer. For more ventilation, roll up the rain cover and secure it by looping the elastic loops around its ends. If it is bright outside or the sun is bothering your child, use the back panel as a sunscreen. To do so, remove the weather cover, flip the back panel over the front of the carrier, secure it to the Velcro tabs located on the upper frame, and re-install the weather cover.

1.4 Suspension Adjustments (Cougar 1 and 2 models only)

All Cougar models come with adjustable suspension. Four adjustment ranges are suggested, but it can be used in any position. The weight ranges suggested are based on the carrier being used for cycling. The setting could be softer or stiffer for strolling/jogging. Experimenting may be required.



75lbs. +	→	50-75lbs	→	25-50lbs.	→	0-25lbs.	→	
		4		3		2		1
34kg +	→	22.5-34kg	→	11-22.5kg	→	0-11kg	→	

Note the 4 positions outlined in **table** where 1 represents the lightest load and 4 represents the heaviest load.

NOTE: To determine the weight, you must combine the weight of the passengers and cargo. To adjust simply loosen knob, slide bracket to desired weight range, and tighten knob.

NOTE: The bracket should be moved to the location next to the weights noted (not on top of the position).

If the suspension is making a hard "knocking" sound, it means the weight setting is too low and you need to slide the bracket further towards the rear. Typically, the suspension on both sides should be set to the same position/range, however it is possible to have them set to different positions if a lighter child is on one side and a heavier child on the other.

1.5 Side Window Removal (CX carriers)



Your CX carrier is equipped with mesh windows that provide maximum ventilation when the clear plastic windows are removed. There are two zippers that need to be unfastened to remove the plastic window. Once removed, place the windows in the rear storage compartment. The side window can be partially zipped open to allow for some ventilation without fully removing the window.

1.6 Rear Storage Compartments



Your Chariot carrier comes with three separate rear storage bags. The first (1) is the rear cargo mesh storage area located directly behind the seat. The second (2) storage area is located on the lower backside of the carrier. The third (3) is a small wallet pocket located inside the mesh storage. The maximum capacity for both storage compartments is 1 kg/2.2 lb.

1.7 Adjusting the Rear Cargo Bag



There are two positions available for the rear cargo bag. The bag can be folded up if not used, or dropped down to easily fill the bag with contents.



To lower or raise the bag, release the quick release skewer on the side of the carrier located just above the top of the wheel.



There are 2 stops built into the mechanism. Either pull the bag down until level with the ground, or push the bag up until the bag will not fold any more. Tighten the quick release skewer, only in either of these positions, by closing it towards the rear of the carrier.

1.8 Parking Brake Instructions (Cougar models only)



The parking brake is located at the center of the rear axle under the rear storage bag.



Engage the parking brake by pressing the plunger down on the brake housing.



Disengage the parking brake by lifting the plunger upwards.

1.9 CX Drum Brakes (CX models only)

The brakes on all CX carriers act as an active brake to help regulate your speed when moving and also as a parking brake. It is very important to keep the brakes adjusted so that the brakes function properly in both circumstances.

Basic Operation

The brake system provided on the CX carrier is a drum brake system. The brakes located on the end of the carrier's rear axle expand, contacting the inside of the rear wheel's hubs, causing the carrier to slow down. Periodic adjustments are required to ensure proper contact between these surfaces.

Braking conditions will vary based on outdoor conditions. For example when the brakes get wet, more force will need to be applied to the hand lever to get the same braking results as in dry conditions. Keep this in mind when using your carrier and before making adjustments to the brakes.



Note the location of the cable guide adjustments. Please see your local dealer with any concerns regarding adjusting these brakes.



When uprighting and folding your carrier, the brake cable ends can shift out from its guides. When this occurs, it will be difficult to place your wheel onto the carrier as the brake is partially applied. To fix this problem, simply apply the brakes by squeezing the hand lever when the carrier is in its upright position.

1.9 CX Drum Brakes (continued)

Parking Brake

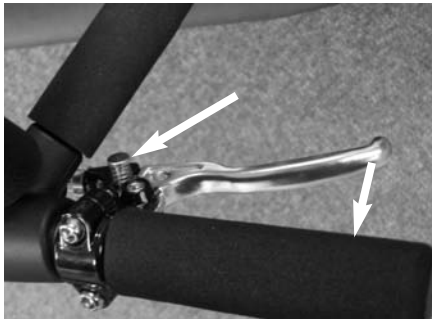

To ensure the carrier remains stationary when parked, the CX carrier uses its drum brakes as a parking brake. To activate the CX parking brake, squeeze the hand lever as tight as you can (pull the lever towards the handlebars). While the lever is fully squeezed push down the locking button. Test for adequate parking brake activation by pushing the carrier. There is nothing wrong if the wheels slowly turn as you push, but as soon as you release the carrier from your grip the brakes should clearly exert sufficient resistance to stop the carrier from rolling. Check that this is the case both forwards and backwards. DO NOT USE THE CARRIER and refer to the "Adjusting the Brakes - Poor Braking" section if the carrier rolls when released.

Adjusting the Brakes - Uneven Braking

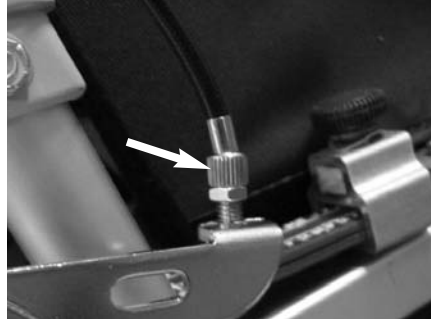

If one wheel is braking much stronger than the other, an adjustment will be needed. Minor differences in braking power between the two wheels is acceptable. If the left brake is stronger than the right, adjust the right brake so that it brakes as well as the left. Perform the opposite adjustment if the right brake is stronger than the left. To tighten a brake, follow these steps.

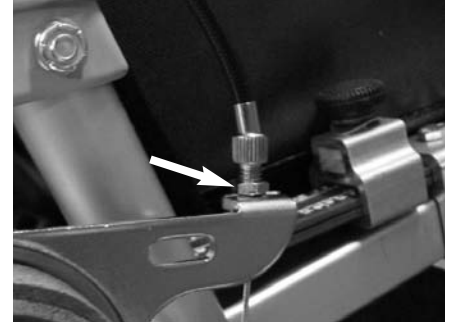

Adjustment 1: Turn the round cable guide counter-clockwise so that the distance between the guide and the brake increases. Perform this operation with the wheel installed on the carrier. If the wheel is difficult to install on or off the carrier, or if you can hear the brake pads rubbing inside the hub on the wheel, you will need to turn the cable guide clockwise slightly to loosen the brake. Once you are satisfied with the braking, turn the small nut clockwise so that the nut is secured to the brake. The nut will prevent the cable guide from loosening during use.

Adjusting the Brakes - Poor Braking



After repeated use, the brakes will need to be adjusted on account of cable stretch and brake pad wear. If the left and right sides are breaking evenly but not as effectively as required, an adjustment needs to be performed. First you need to locate the cable guide inside the rear storage pouch located behind the seat.

Adjustment 1: Turn this guide counter clockwise threading the guide out of the black casing. This adjustment should improve the braking on both pads.

Make this adjustment with the wheels on the carrier. If you can hear the brake pads rubbing inside the hub on the wheel you will need to turn the cable guide clockwise to loosen the brake slightly. Once you are satisfied with the braking, turn the nut clockwise so that the nut is secured to the black casing. The nut will prevent the cable guide from loosening. The cable guide will fall out of the black casing if it is threaded out too far. In this event, thread it back in a few rotations and proceed to "Adjustment 2".

Adjustment 2: There is another cable guide that can be adjusted on the hand lever. Turn this guide counter-clockwise also to increase the brakes effectiveness further. Once adjusted be sure to tighten the small nut as described in "Adjustment 1". This cable guide is also restricted in the amount of adjustment. When the majority of the guide has been threaded out proceed to "Adjustment 3".

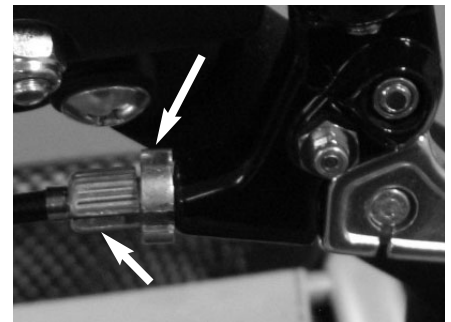

Adjustment 3: Once no additional adjustments can be made to cable guides on the black casing or the hand lever, adjustments can be made to the individual brakes themselves. Follow the explanation in "Adjusting the Brakes - Uneven Braking" above, however perform the same number of turns to each side to keep the braking equal.

1.9 CX Drum Brakes (continued)

Worn out Brake Pads

Eventually the brake pads could wear down and need to be replaced. The pads are worn when they become thin or when you squeeze the hand lever and braking is not satisfactory when the brakes are properly adjusted. When this occurs, you will no longer be able to squeeze the lever and bring the carrier to a stop. When this occurs, **DO NOT USE THE CARRIER**. Return to your Chariot dealer for brake pad replacement.

Note: The original shape of the brake pads is tapered with the appearance that one end is worn out. This is not the case. The pads are tapered as part of the design for maximum brake performance.

Maintenance

If you've used your carrier in wet conditions, dry off the brakes and the inside of the brake hubs immediately after use using a grease free rag. Wear within the brake and outside dust can clog the braking areas. As such periodically clean the area with a grease free brush (eg. a paintbrush). Maintaining a dry and clean brake system will ensure better long term braking.

With the wheels installed, the wheel hub offers the internal workings of the brake good protection against external factors, but with the wheels off the opposite is true – the brakes workings are unprotected and highly susceptible to damage. Please take this into account by handling a carrier with no wheels carefully, particularly when moving it.

WARNING: Ensure the parking brake is properly functioning before each use. On hilly terrain you should always remain in close proximity to the carrier and use the safety wrist strap, so that you can immediately stop the carrier from rolling or slipping if the need arises. Failure to do so could cause the carrier to roll away, resulting in a serious accident.

WARNING: Even with these brakes properly adjusted, descend all hills at a walking pace as the brakes can overheat or malfunction, leading to possible brake failure and a serious accident.

WARNING: Because these brakes rely on friction, the wheel hubs can become very hot to the touch and can burn your skin. As such, let the wheels cool before removing them from the carrier.

1.10 Child Placement and Seatbelts

WARNING: Failure to properly attach seatbelts could result in serious injury or death to occupants in the event of an accident.

WARNING: Failure to seat a single child in the center position could cause the carrier to tip over causing serious injury or death.

WARNING: Always adjust shoulder harness and crotch strap so they meet at child's lower chest. Adjusting harnesses and buckles near your child's neck could cause serious injury.

TWO CHILDREN

1. Undo the two buckles located at the top of the padded shoulder harness, leaving it attached to the crotch belt, but flipped down.
2. Seat your child(ren).
3. Slide the shoulder belt height adjustment located on the vertical web straps, in the seat back, to the same height as your child(ren)'s shoulders.
4. Lift up the shoulder harness and connect the buckles over each shoulder. Be careful to not pinch your child's neck.
5. Adjust the system using the crotch belt and shoulder belt length adjustments until the Chariot logo located on the shoulder harness is positioned over their lower chest.
6. Buckle the waist belt(s) around their hips. The waist belt goes in front of the crotch belt and the buckle should be centered.
7. Snugly tighten all belts.

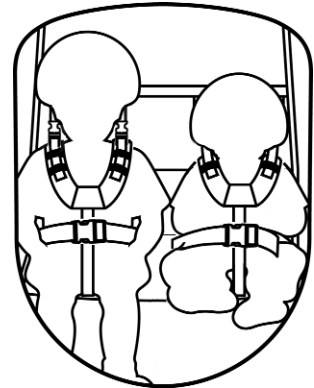

ONE CHILD

1. Use the center seating position.
2. Move a padded shoulder harness to the center seating position, thus using the center crotch belt and the two middle shoulder buckles.
3. Use the two middle waist belts and buckles.
4. The two outboard waist belts, two outboard crotch belts and one shoulder harness are not used. Safely tuck them aside in the carrier. Do not remove them.
5. Go to section **TWO CHILDREN**

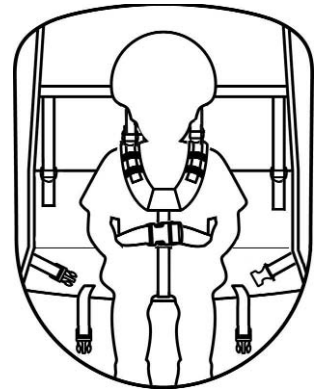

ADJUSTING THE PADDED SHOULDER HARNESS

1. Unbuckle and remove the padded shoulder harness from the carrier. To undo the buckle hidden behind the Chariot logo, squeeze in from the sides of the fabric cover.
2. Located on the upper front of the shoulder harness are three adjustment loops per side: two made of webbing, one of cord. You will use these to fit the shoulder harness to one of four different sizes: XS, S, M & L.
3. To achieve the correct size, sleeve through or remove the shoulder belts with the plastic buckle through these adjustment loops, as indicated below:
XS: Do not sleeve through any adjustment loops; thus unsleeve the shoulder belts from all loops.
S: Only sleeve through the lowest webbing loop. When sized for XS and S, the un-used, upper sections of the shoulder harness go loose over their shoulders. Smooth them down their back for comfort.
M: Sleeve through both webbing loops. This is the default setting.
L: Sleeve through both webbing loops and the top cord loop.
4. Reinstall the shoulder harness into the carrier using the three plastic buckles. The male buckle on the crotch belt clips into the female buckle behind the logo in the shoulder harness.
5. Go to section **ONE CHILD** or **TWO CHILDREN**.

Notes: The padded shoulder harness should be symmetrical and level (the Chariot logo should be horizontal). Do not cross the shoulder belts to use up extra shoulder belt length. Do not pass the shoulder harness under an infant's arms to hold them in a sitting position. Use a Baby Bivy, an Infant Sling or a Baby Supporter with a child that cannot sit upright unsupported.

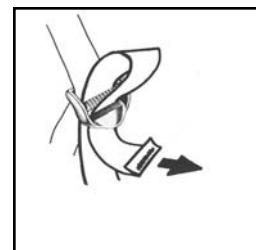
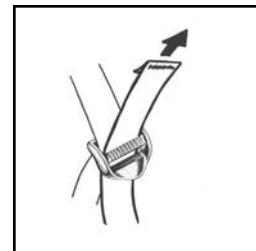

PARTS LIST Cougar 1

Part #	Part	Quantity
A	40100148	Upper Frame1
B	41100227	Lower Frame2
C	41101290	Lower Frame Bracket2
D	40100406	Back Frame – Left1
E	40100407	Back Frame – Right1
F	40100704	Back Tube2
G	40100626	Seat Frame1
H	40100449	Cargo Bag Frame1
I	40101516	Wheel Arm Attachment Bracket – Left1
J	40101517	Wheel Arm Attachment Bracket – Right1
K	40101281	Back Bracket – Left1 Set
L	40101282	Back Bracket – Right1 Set
M	50203031	Shoulder Harness1
N	50101729	Alloy Wheel2
O	50101305	Clevis Axle2
P	31100506/7	Weather Cover1
Q	30100509/10	Fabric Body1
R	41103032	Axle Adapter2
S	40101311	Handlebar1
T	40202011	Wrist Safety Strap1
U	40101730	Parking Brake Assembly with Axle1
V	33100507/8	Rear Storage Bag (not shown)1
W	41101929	Parking Brake Hub (not shown)2
X	41101272/4	Click n' Store Left1
Y	41101273/5	Click n' Store Right1
Z	41101276/8	Cargo Frame Brackets Left1
AA	41101278/9	Cargo Frame Brackets Right1
BB	50103070	Quick release Skewers2

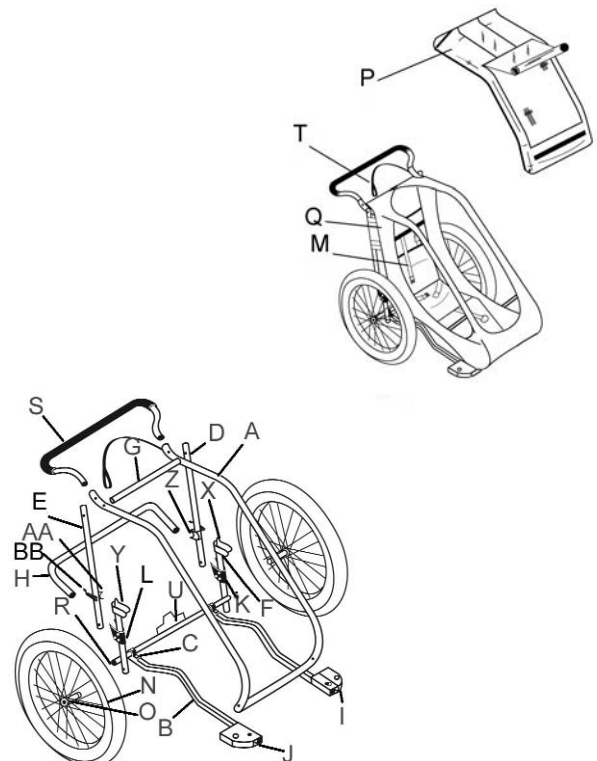

PARTS LIST Cougar 2

Part #	Part	Quantity
A	40100149	Upper Frame1
B	41100227	Lower Frame2
C	41101290	Lower Frame Bracket2
D	40100406	Back Frame – Left1
E	40100407	Back Frame – Right1
F	40100704	Back Tube2
G	40100624	Seat Frame1
H	40100451	Cargo Frame Bag1
I	40101516	Wheel Arm Attachment Bracket – Left1
J	40101517	Wheel Arm Attachment Bracket – Right1
K	40101281	Back Bracket – Left1 Set
L	40101282	Back Bracket – Right1 Set
M	50203031	Shoulder Harness2
N	50101729	Alloy Wheel2
O	50101305	Clevis Axle2
P	31100903/4	Weather Cover1
Q	30100907/8	Fabric Body1
R	41103032	Axle Adapter2
S	40100627	Lower Seat Bar1
T	40101338	Handlebar1
U	40202011	Wrist Safety Strap1
V	40101736	Parking Brake Assembly with Axle1
W	33100906/7	Rear Storage Bag (not shown)1
X	41101929	Parking Brake Hub (not shown)2
Y	41101272/4	Click n' Store Left1
Z	41101273/5	Click n' Store Right1
AA	41101276/8	Cargo Frame Brackets Left1
BB	41101277/9	Cargo Frame Brackets Right1
CC	50103070	Quick Release Skewers2

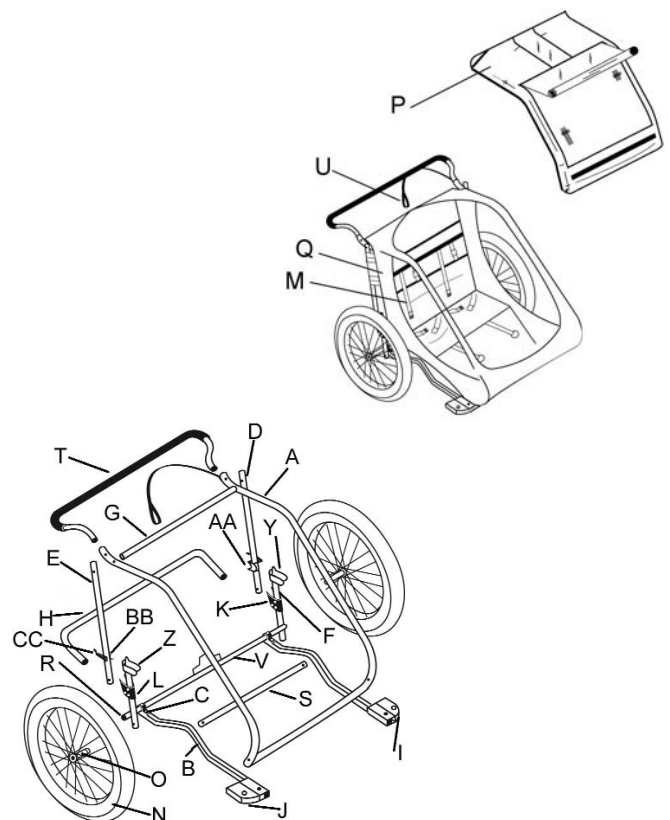

PARTS LIST CX 1

Part #	Part	Quantity
A	40100151	Upper Frame1
B	41100227	Lower Frame2
C	41101290	Lower Frame Bracket2
D	40100406	Back Frame – Left1
E	40100407	Back Frame – Right1
F	40100704	Back Tube2
G	40100626	Seat Frame1
H	40100449	Cargo Bag Frame1
I	40101516	Wheel Arm Attachment Bracket – Left1
J	40101517	Wheel Arm Attachment Bracket – Right1
K	40101281	Back Bracket – Left1 Set
L	40101282	Back Bracket – Right1 Set
M	50203045	Shoulder Harness1
N	50101703	Alloy Wheel2
O	50101309	Clevis Axle2
P	31101003	Weather Cover1
Q	30101005	Fabric Body1
R	50102002	Axle Adapter2
S	40101337	Handlebar1
T	40202011	Wrist Safety Strap1
U	50102001	Left Brake1
V	50102003	Right Brake1
W	33101004	Rear Storage Bag (not shown)1
X	41101272/4	Click n' Store Left1
Y	41101273/5	Click n' Store Right1
Z	41101276/8	Cargo Frame Brackets Left1
AA	41101278/9	Cargo Frame Brackets Right1
BB	50103070	Quick release Skewers2

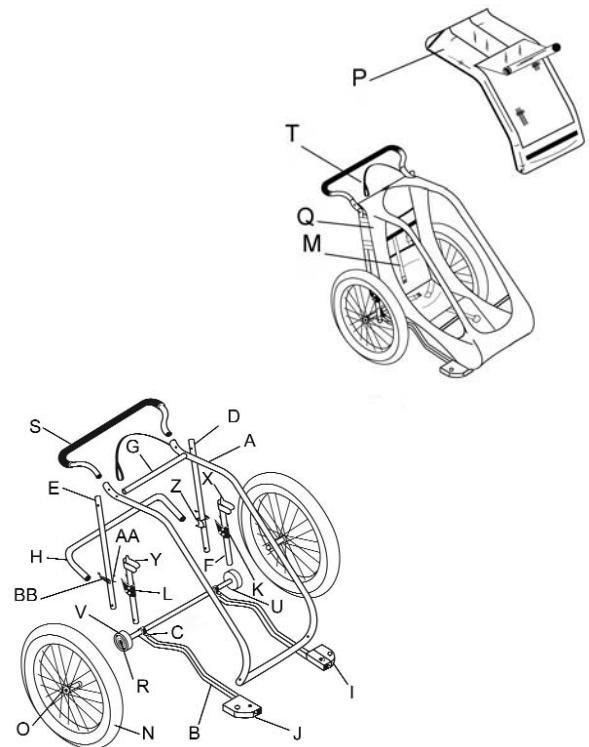

PARTS LIST CX 2

Part #	Part	Quantity
A	40100152	Upper Frame1
B	41100227	Lower Frame2
C	41101290	Lower Frame Bracket2
D	40100406	Back Frame – Left1
E	40100407	Back Frame – Right1
F	40100704	Back Tube2
G	40100624	Seat Frame1
H	40100451	Cargo Frame Bag1
I	40101516	Wheel Arm Attachment Bracket – Left1
J	40101517	Wheel Arm Attachment Bracket – Right1
K	40101281	Back Bracket – Left1 Set
L	40101282	Back Bracket – Right1 Set
M	50203045	Shoulder Harness2
N	50101703	Alloy Wheel2
O	50101309	Clevis Axle2
P	31101004	Weather Cover1
Q	30101006	Fabric Body1
R	50102002	Axle Adapter2
S	40100627	Lower Seat Bar1
T	40101339	Handlebar1
U	40202011	Wrist Safety Strap1
V	50102001	Left Brake1
W	50102003	Right Brake1
X	33101005	Rear Storage Bag (not shown)1
Y	41101272/4	Click n' Store Left1
Z	41101273/5	Click n' Store Right1
AA	41101276/8	Cargo Frame Brackets Left1
BB	41101277/9	Cargo Frame Brackets Right1
CC	50103070	Quick Release Skewers2

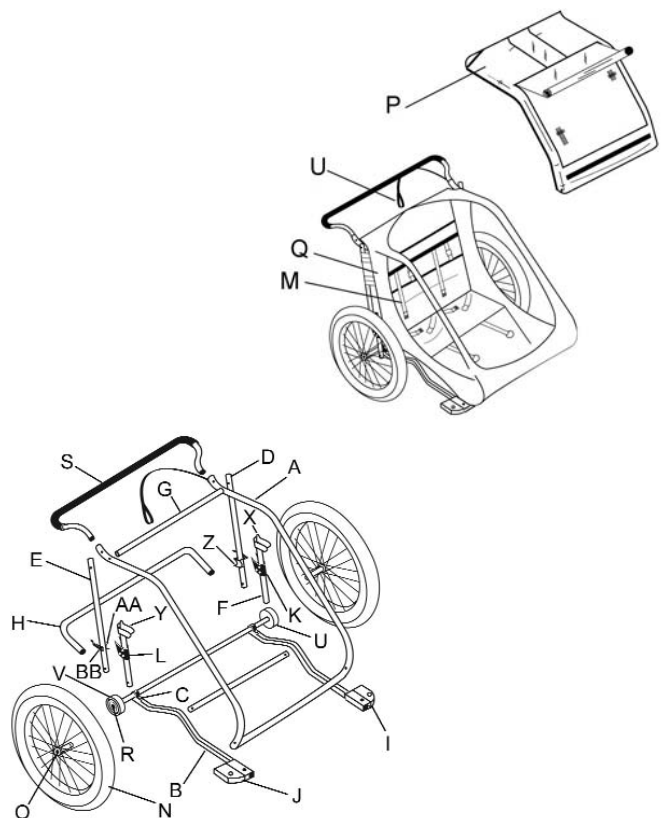

STROLLING CTS KIT (wheels only)



2.0 Installation



Push the button located on the side of the wing as far in as possible. This will create an opening for the caster shaft.



While maintaining the button depressed, slide the stroller caster from the bottom up into the carrier's wing. When fully inserted, release the button and it should return to its locked position. To make sure the caster is secured, test by trying to pull the caster down.

2.1. Storage



To store the wheels on the carrier when using another conversion kit, turn the wheel assembly upside down angled towards the back of the carrier. While maintaining the button depressed, slide the wheel down into the opening, then release the button once fully inserted.

WARNING:

Overloading the carrier with more than 2.2 lb (1 kg) in the rear storage pouches can make the carrier unstable.

Failure to properly attach wheels could cause the wheels to fall off, resulting in an accident and serious injury.

Direct impacts against the pivoting stroller wheels could cause damage to the wheel arm attachment brackets.

The following safety precautions should be followed, otherwise injury or death to you or to your passengers could result:

- Use wrist safety strap at all times.
- Always use seat belts.
- Always use parking brake when stroller is stationary.
- Never in-line skate with the stroller kit.
- Never climb or descend stairs with the stroller.
- Use extreme caution on hills.

JOGGING CTS KIT



3.0 Installation



Remove any other conversion kits from the wheel wheel arm attachment bracket. Insert the wheel arms by pressing the small button and sliding the arm into the wheel arm attachment bracket. The large button should engage into the hole on the wheel arm attachment bracket.

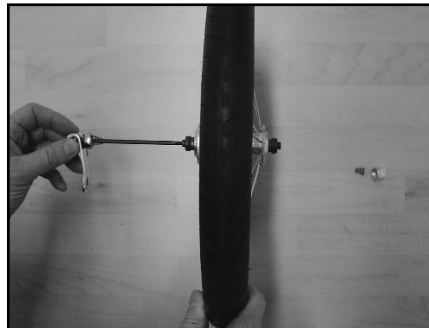

Install the quick release axle through the wheel's hollow axle with a spring on each side of the wheel. Screw the nut onto the other side of the skewer axle.



Slide the wheel axle all the way into the wheel bracket dropouts.

With the quick release lever opened 90° to the wheel brackets (ie. pointing straight out), hand-tighten the nut on the back side of the quick release skewer.



Close the quick release lever by pushing it flat against the wheel bracket. When the nut is properly adjusted, you will feel resistance halfway through tightening the lever. Make sure the lever is closed towards the back of the carrier.

WARNING:

Failure to properly attach wheels could cause the wheels to fall off, resulting in an accident and serious injury.

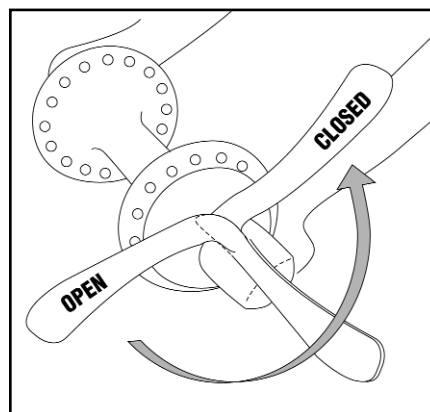

WARNING:

Overloading the carrier with more than 2.2lb (1kg) in the rear storage pouches can make the carrier unstable.

WARNING:

The following safety precautions should be followed otherwise injury or death to you or to your passengers could result:

- Use wrist safety straps at all times.
- Always use seat belts.
- Always use parking brake when stroller is stationary.
- Never in-line skate with the jogging kit.
- Never climb or descend stairs with the jogging kit.
- Use extreme caution on hills.

3.1 Storage



There are 3 straps attached to the outside of the storage compartment that you can use to attach the front wheel of your jogger to in the event you have purchased both a Cycling kit and Jogging kit but wish to keep the Jogging kit components with the carrier. The wheel arms can be placed inside the storage compartment or on the side of the carrier if you own a Cougar or a CX carrier.



The wheel arms can be stored on the side of the carrier. Press down the small button, and insert the wheel arm into the bracket located on the side of the carrier. The large button should engage into the hole in the bracket.



Keep the left wheel arm on the left side of the carrier and right arm on the right side so that the arm's dropouts rest under the carrier's lower frame.

CYCLING CTS KIT



WARNING: Read and understand all of the warnings otherwise injury or death to you or to your passengers could result:

- Always use safety flag.
- Do not operate the bicycle trailer without reading and understanding this manual.
- Use extreme caution while trailering, never exceed 25 km/h and slow down to less than 10 km/h around corners and on rough roads.
- Cyclist must be an experienced, strong rider.
- Avoid all obstacles as carriers can tip over causing serious injuries to the passenger and cyclist.
- Passenger must always use seat belts and wear an approved helmet.
- Child's head, including helmet, must not protrude above upper frame.
- Never leave child unattended in carrier.
- Child must be old enough to wear a helmet and to sit upright unattended. Consult pediatrician if child is less than one year old.
- Child's head, including helmet, must not protrude above upper frame.
- Do not exceed the maximum capacity for a single carrier of 75lb (34kg) and for a double carrier of 100 lb (45kg) including children and cargo.

4.0 Reflectors and Flag Assembly



Attach the reflector to the spokes.

Insert the orange clip into the reflector and over the spoke. With a slot screwdriver, turn the clip until reflector is tight and unable to shift.

Attach the red reflector to the left grommet on the rear of the back storage bag.

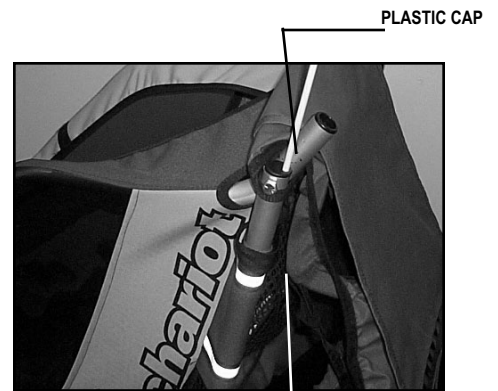

LOCATION FOR FLASHING CLIP ON LIGHT

Insert the flag into hole located in the plastic cap on the upper left rear side of frame. Slide the flag down into hole until flag touches the bottom of the tube.

Note: For additional visibility you may wish to purchase a battery powered clip-on light from your local Chariot retailer. This light can be connected to the top rear of the

4.1 Attaching Your New Quick Release (QR) Skewer & Axle Mounted Hitch Cup to Your Bicycle



Remove your existing QR skewer from your bicycle rear wheel hub. Remove the QR nut and one Skewer Spring from the Hitch QR Skewer.

Insert the Hitch QR Skewer making sure that the cup washer is next to the QR Lever and the Axle Mounted Hitch Cup is on the outside of the bicycle frame drop out. Ensure that the Axle Mounted Hitch Cup is oriented so that the cup itself is below the Hitch QR Skewer and the cup opening is facing forward.



Note: the small diameter of the Skewer Springs should point inward towards the hub axle.

Position the Hitch QR Lever so it points straight out from the hub (open position). Tighten the QR Nut on the opposite end of the Hitch QR Skewer until finger tight.



Move the Hitch QR Lever to the closed position. It should take a noticeable amount of force to close the lever (it should leave an imprint of the lever on your palm). The Hitch QR Lever should always be closed so that the lever points to the rear of the bike. This will prevent the Hitch QR Lever from catching and opening while you are riding.

4.2 Attaching Your Axle Mounted Hitch Cup to Your Bicycle if You Have a Solid Axle Style Hub

Note: The hitch QR skewer will not be used with a solid axle style hub.

Remove the axle nut from your bicycles rear wheel hub axle (Note: if there is a washer, remove and discard it – the Axle Mounted Hitch Cup will replace it). Install the Axle Mounted Hitch Cup on the wheel hub axle. Ensure that the Axle Mounted Hitch Cup is oriented so that the cup itself is below the solid Axle Bolt and the cup opening is facing forward. Reinstall the axle nut and tighten

WARNING: Failure to properly install and tighten the QR skewer or axle nut could cause hitch failure and wheel loss resulting in serious injury or death.

4.3 Hitch arm Assembly

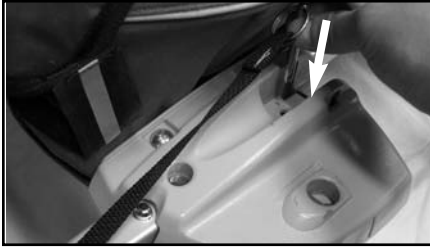

Remove any other conversion kits from the wheel arm attachment bracket. Insert the hitch arm by pressing the small button and sliding the arm into the wheel arm attachment bracket. The large button should engage into the hole on the wheel arm attachment bracket.

Insert the securing pin down through the small rear hole in the wheel arm attachment bracket.

4.4 Attaching Your Carrier to the Hitch Cup on Your Bicycle

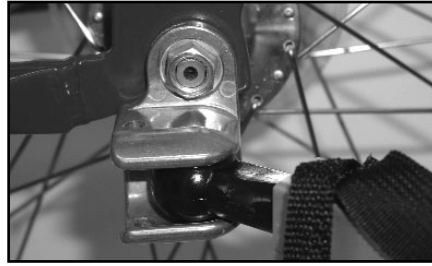

Place the CH-5 Hitch Ball into the Axle Mounted Hitch Cup (inserted from the forward open end). Fully insert the hitch ball into the Axle Mounted Hitch Cup.



Place the Securing Pin through the holes on the front of the Axle Mounted Hitch Cup so as to trap the CH-5 Hitch Ball in the Axle Mounted Hitch Cup. The Securing Pin must be installed from the top of the Axle Mounted hitch cup. Pull the rubber strap over the front of the Axle Mounted Hitch Cup and over the securing pin end. The "Chariot" logo should face forward.



Wrap the Hitch Back-up Safety Strap around the bicycle chainstay and attach the safety clip to the D-ring on the hitch arm. If the Hitch Back-up Safety Strap is not long enough to wrap around the bicycle chainstay (because of a non typical rear triangle), wrap it around the rear axle flange (between the drop out and the wheel hub).

Failure to insert securing pin could cause the carrier to separate from the bicycle resulting in an accident and serious injury.

Failure to properly attach the hitch back-up safety strap could result in loss of carrier and serious injury or death to the occupants.

Do not use the hitch if you cannot properly install the hitch back-up safety strap to your bicycle. See your Chariot Dealer for possible alternatives.

4.5 Hitch Arm Storage

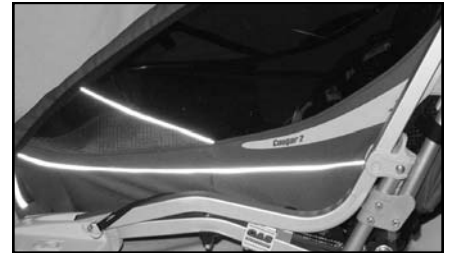

The hitch arm can be stored on the side of the carrier. The carrier must be fully uprighted to do so. Insert the long straight section of the hitch arm into the bracket on the side of the carrier. Slide the arm down until the end of the hitch arm fits into the carrier's front wheel arm attachment bracket.

4.6 Pull Wagon



Using the pin riveted onto the hitch arm, push the pin through upper horizontal hole in the wheel arm attachment bracket, thereby securing the hitch arm.



For a short distance on flat terrain, the hitch arm can be rotated and used as a pulling device. From a passenger's perspective, rotate the hitch arm 90 degrees counter-clockwise. The strap should be pointing towards the outside of the carrier. Push down the small button on the hitch arm and slide it into the left wheel arm attachment bracket. You will not be able to see the large button engage, however check that engagement has occurred by making sure you can not pull the arm from the carrier. Insert the securing pin through horizontal hole as in section 4.5.

X-COUNTRY SKIING CTS KIT



Because of the unique axles used on the CX carrier, a separate steel axle adapter kit is required. This kit needs to be retro-fitted onto the ski kit arms. Without this kit, the ski frame arms will fall off the carrier during use. See your dealer to obtain a set of this kit.

5.0 Installation



Remove any other conversion kits from wheel arm attachment brackets. Insert X-Country skiing arms into the wheel arm attachment brackets and secure using safety snap pins.

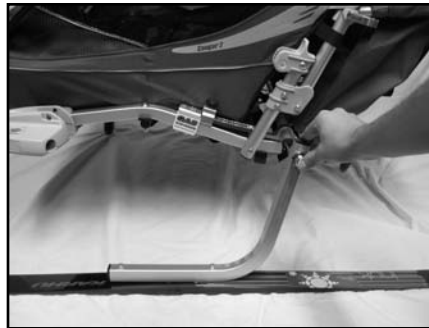

Insert the X-Country skiing axle into the hollow axle on the carrier.

WARNING: Failure to properly attach XC skiing kit arms and axles could cause the carrier to separate from you, resulting in an accident and serious injury or death.

5.1 Shoulder Harness Adjustments



The waist belt comes adjusted in the largest setting, however you may adjust to a narrower setting by removing the bolts and reattaching them to the rear grommets.

Securely attach the waist harness around your waist with the buckle in front and the poles adjusted to your hip area.

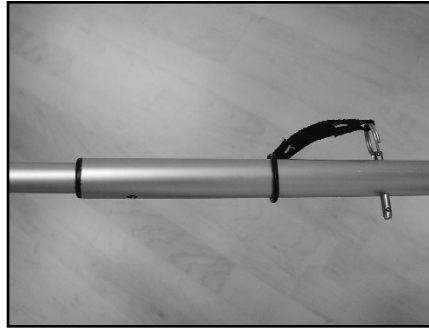

Adjust the length of the XC skiing kit arms by sliding the inner tube out until the hole on the inner tube lines up with the hole on the outer tube. Insert securing pin.

Note: The arms have 3 adjustment positions.

WARNING:

Read and understand all of the warnings otherwise injury or death to you or to your passengers could result:

- Only an experienced skier should use the X-Country skiing kit.
- Do not exceed the maximum load recommended for your carrier.
Important: This weight may be too heavy for some skiers.
- The extra length and width of the XC skiing kit will require additional attention while passing others on the trail or skiing on narrower trails.
- Always use seat belts.
- Never leave children unattended in carrier.
- Regularly monitor your children to ensure they are comfortable and warm.
- Do not X-Country ski below -20°C. Plastic windows can crack at these low temperatures.
- Never use your X-Country skiing kit for down hill skiing and never tow it behind a snow mobile.
- Use extreme caution on hills, aggressive trails, and when stopping!
- Take the X-Country skiing kit for a practice run (weighted greater than your expected load with children and cargo) over more various terrain than you expect to ski, until you are skilled in handling the X-Country skiing kit. Have another adult with you to assist you in case you run in to difficulties (i.e. X-Country skiing kit is too heavy for the terrain you were expecting to ski).
- Make sure the length of the arms on your XC skiing kit are adjusted correctly, to ensure that your skis or poles will not be in contact with the carrier.

HIKING CTS KIT



6.0 Installation



Remove any other conversion kits from wheel arm attachment brackets. Insert hiking kit arms into wheel arm attachment brackets and secure using safety snap pins.

WARNING: Failure to properly attach hiking kit arms could cause the carrier to separate from you resulting in serious injury or death to the passengers.



Adjust the front shoulder straps, up or down, so that the waist belt is level with your waist.

6.1 Shoulder Harness Adjustments



Adjust rear shoulder strap so that the point where the strap inserts into the buckle is 75mm (3 inches) below the base of your neck.



Adjust the width of the waist belt so that the hiker bars are spaced "hip width" apart.

Optional: Secure the sternum strap and adjust its height and tension.

Note: These adjustments are general guidelines. Make the necessary adjustments to maximize your comfort.

WARNING:

Read and understand all of the warnings otherwise injury or death to you or to your passengers could result:

- Never in-line skate or run with the hiking kit.
- Use extreme caution on steep hills, aggressive trails, and when stopping! When descending, use the handles for additional support.
- Take the hiking kit for a practice hike (weighted greater than your expected load with children and cargo) over more various terrain than you expect to hike until you are skilled in handling the carrier. Have another adult with you to assist in case the carrier is too heavy.
- Do not exceed the maximum load recommended for your carrier. *Important: This weight may be too heavy for some hikers.*
- The extra length of the hiking kit and carrier will require more time and room to cross intersections and to negotiate corners.
- Always use seat belts.
- Never leave children unattended in carrier.

ACCESSORIES

The following high quality Chariot accessories are available for purchase at your local Chariot retailer.

CHARIOT ACCESSORIES:

Hydration Kit: Water bottles and brackets for Jogging/Strolling Kits.

Jogging Brake Kit 2.0: Brake and attachments. Cheetah carriers require a different brake than the Cougars and CX carriers.

Travel Bag 1: Heavy duty travel bag with wheel covers for single child carriers.

Travel Bag 2: Heavy duty travel bag with wheel covers for double child carriers.

Chariot Backpack Set: A backpack/diaper bag for parent and a small backpack for junior.

Axle-Mount ez-Hitch™ - Partial: Hitch components required for adding a hitch to a second bike.

Storage Cover 1: A cover to protect single child carriers from the elements (while stored).

Storage Cover 2: A cover to protect double child carriers from the elements (while stored).

Plastic Rain Cover: Additional rain protection for single child carriers

Plastic Rain Cover: Additional rain protection for double child carriers.

Infant Sling: A lateral support sling for the youngest Chariot passengers.

Bunting Bag: An over-sized, all season bunting bag.

Baby Supporter: To assist a baby with sitting upright and adds extra comfort during naps.

Baby Bivy: A small, soft carrying cot that clips in and out of your Chariot.

X-Country Cargo Rack 1: Add ultra convenient supplemental storage for single child carriers

X-Country Cargo Rack 2: Add ultra convenient supplemental storage for double child carriers.

Fender Kit: Includes two deflective side bumpers and two Zefel splash guards

Notes



LIMITED LIFETIME WARRANTY/GARANTIE À VIE LIMITÉE

CHARIOT CARRIERS INC. warrants that the frame is free of defects for the lifetime of the product. The fabric and hitch are warranted for one year following the date of delivery to the original purchaser. This warranty does not include the wheels and tires. This warranty is valid only to the original purchaser and under normal use.

Repairs must be made by **CHARIOT CARRIERS INC.** or an authorized dealer, otherwise this warranty is void. **CHARIOT CARRIERS INC.** reserves the right to repair or replace the warranted carrier.

This warranty does not apply to damages caused by misuse of this product, accidental or intentional damage, neglect or commercial use. Excluded from this warranty is liability for consequential property or commercial damages or for damages for loss of use.

This constitutes the only warranty of **CHARIOT CARRIERS INC.** and its authorized agents and dealers and no other warranty or conditions, statutory, parole, collateral or otherwise (including conditions requiring compliance with description, fitness for purpose and merchantable quality) shall be implied.

CHARIOT CARRIERS INC. garantit le cadre contre tout défaut tant que le produit sera utilisé et garantit aussi le tissu ainsi que le dispositif d'attelage pendant un an à compter de la date de livraison du produit à l'acheteur d'origine. La présente garantie ne s'applique pas aux roues ni aux pneus et elle n'est valable que pour l'acheteur d'origine, dans des conditions normales d'utilisation.

Les réparations doivent être effectuées par **CHARIOT CARRIERS INC.** ou un détaillant autorisé sans quoi la garantie devient nulle et non avenue. **CHARIOT CARRIERS INC.** se réserve le droit de réparer ou de remplacer la remorque.

La présente garantie ne s'applique pas à des problèmes découlant d'une utilisation abusive du produit, aux dommages intentionnels ou accidentels, aux cas de négligence ni à ceux d'utilisation à des fins commerciales. La garantie ne porte pas non plus sur la responsabilité pour dommages indirects à la propriété ou aux biens, ni à la privation de jouissance. Il s'agit de la seule garantie accordée par **CHARIOT CARRIERS INC.** et ses détaillants ou agents autorisés. Aucune autre garantie ou condition réglementaire, verbale, accessoire ou autre (y compris toute condition exigeant la conformité à la description, à l'usage souhaité ou à la qualité marchande) n'est sous-entendue.

WARRANTY/GARANTIE

To validate your warranty and for contacting you for any future potential safety notices, please complete the following information and send to: *Pour que votre garantie entre en vigueur, fournissez les renseignements suivants et faites-les parvenir à:* Chariot Carriers Inc., Bay F, 6810 – 6th Street SE, Calgary, Alberta, T2H 2K4, CANADA . You can also validate your warranty on-line at www.chariotcarriers.com.

Name/Nom: _____ Model/Modèle: _____

Address/Adresse: _____ Serial #/N° de Série: _____ / _____ - _____
M Y/A #/N°

City/Ville: _____ Province or State: _____ Country/Pays: _____

Postal Code or Zip Code/Code Postal: _____ Telephone/Téléphone: (_____)

Date of Purchase/Date d'achat: _____ Store & Location/Magasin et Ville: _____

I purchased a **CHARIOT CARRIER** for the following reason(s)/J'ai choisi **CHARIOT CARRIER** pour les raisons suivantes:

- reasonable price/prix raisonnable
- easy to assemble/facile à assembler
- recommended by friend/recommandation
- the many features/caractéristiques
- quality of product/qualité du produit
- North American made/fait au Amérique du Nord
- visited Chariot's web site/consultation du site web
- saw an advertisement/publicité
- lifetime warranty/garantie à vie
- CTS Conversion Kits/trousses CTS
- recommended by salesperson/vendeur

Additional comments/autres commentaires:

Free Manuals Download Website

<http://myh66.com>

<http://usermanuals.us>

<http://www.somanuals.com>

<http://www.4manuals.cc>

<http://www.manual-lib.com>

<http://www.404manual.com>

<http://www.luxmanual.com>

<http://aubethermostatmanual.com>

Golf course search by state

<http://golfingnear.com>

Email search by domain

<http://emailbydomain.com>

Auto manuals search

<http://auto.somanuals.com>

TV manuals search

<http://tv.somanuals.com>