

# 10" Compound Power Miter Saw

(Model MS275)



PART NO. A06546 - 04-29-05  
Copyright © 2005 Delta Machinery

 **DELTA**<sup>®</sup> *ShopMaster*<sup>™</sup>

To learn more about DELTA MACHINERY  
visit our website at: [www.deltamachinery.com](http://www.deltamachinery.com).

For Parts, Service, Warranty or other Assistance,

please call **1-800-223-7278** (In Canada call **1-800-463-3582**).

**ESPAÑOL: PÁGINA 21**

# TABLE OF CONTENTS

IMPORTANT SAFETY INSTRUCTIONS .....	2
SAFETY GUIDELINES .....	3
GENERAL SAFETY RULES .....	4
ADDITIONAL SPECIFIC SAFETY RULES .....	5
FUNCTIONAL DESCRIPTION .....	7
CARTON CONTENTS .....	7
ASSEMBLY .....	8
OPERATION .....	11
TROUBLESHOOTING .....	18
MAINTENANCE .....	18
SERVICE .....	19
ACCESSORIES .....	20
WARRANTY .....	20
ESPAÑOL .....	21
SERVICE CENTER LOCATIONS .....	back cover

## IMPORTANT SAFETY INSTRUCTIONS

**⚠ WARNING** Read and understand all warnings and operating instructions before using any tool or equipment. When using tools or equipment, basic safety precautions should always be followed to reduce the risk of personal injury. Improper operation, maintenance or modification of tools or equipment could result in serious injury and property damage. There are certain applications for which tools and equipment are designed. Delta Machinery strongly recommends that this product NOT be modified and/or used for any application other than for which it was designed.

If you have any questions relative to its application DO NOT use the product until you have written Delta Machinery and we have advised you.

Online contact form at [www.deltamachinery.com](http://www.deltamachinery.com)

Postal Mail: Technical Service Manager  
Delta Machinery  
4825 Highway 45 North  
Jackson, TN 38305

(IN CANADA: 125 Mural St. Suite 300, Richmond Hill, ON, L4B 1M4)

Information regarding the safe and proper operation of this tool is available from the following sources:

Power Tool Institute  
1300 Sumner Avenue, Cleveland, OH 44115-2851  
[www.powertoolinstitute.org](http://www.powertoolinstitute.org)

National Safety Council  
1121 Spring Lake Drive, Itasca, IL 60143-3201

American National Standards Institute, 25 West 43rd Street, 4 floor, New York, NY 10036 [www.ansi.org](http://www.ansi.org)  
ANSI 01.1 Safety Requirements for Woodworking Machines, and

the U.S. Department of Labor regulations [www.osha.gov](http://www.osha.gov)

**SAVE THESE INSTRUCTIONS!**

# SAFETY GUIDELINES - DEFINITIONS

It is important for you to read and understand this manual. The information it contains relates to protecting YOUR SAFETY and PREVENTING PROBLEMS. The symbols below are used to help you recognize this information.



- ▲ DANGER** Indicates an imminently hazardous situation which, if not avoided, will result in death or serious injury.
- ▲ WARNING** Indicates a potentially hazardous situation which, if not avoided, could result in death or serious injury.
- ▲ CAUTION** Indicates a potentially hazardous situation which, if not avoided, may result in minor or moderate injury.
- CAUTION** Used without the safety alert symbol indicates potentially hazardous situation which, if not avoided, may result in property damage.

---

## CALIFORNIA PROPOSITION 65

**▲ WARNING** **SOME DUST CREATED BY POWER SANDING, SAWING, GRINDING, DRILLING, AND OTHER CONSTRUCTION ACTIVITIES** contains chemicals known to cause cancer, birth defects or other reproductive harm.

Some examples of these chemicals are:

- lead from lead-based paints,
- crystalline silica from bricks and cement and other masonry products, and
- arsenic and chromium from chemically-treated lumber.

Your risk from these exposures varies, depending on how often you do this type of work. To reduce your exposure to these chemicals: work in a well ventilated area, and work with approved safety equipment, always wear **NIOSH/OSHA** approved, properly fitting face mask or respirator when using such tools.

# GENERAL SAFETY RULES



**⚠ WARNING** READ AND UNDERSTAND ALL WARNINGS AND OPERATING INSTRUCTIONS BEFORE USING THIS EQUIPMENT. Failure to follow all instructions listed below, may result in electric shock, fire, and/or serious personal injury or property damage.

## IMPORTANT SAFETY INSTRUCTIONS

- FOR YOUR OWN SAFETY, READ THE INSTRUCTION MANUAL BEFORE OPERATING THE MACHINE.** Learning the machine's application, limitations, and specific hazards will greatly minimize the possibility of accidents and injury.
- WEAR EYE AND HEARING PROTECTION. ALWAYS USE SAFETY GLASSES.** Everyday eyeglasses are NOT safety glasses. USE CERTIFIED SAFETY EQUIPMENT. Eye protection equipment should comply with ANSI Z87.1 standards. Hearing equipment should comply with ANSI S3.19 standards.
- WEAR PROPER APPAREL.** Do not wear loose clothing, gloves, neckties, rings, bracelets, or other jewelry which may get caught in moving parts. Nonslip footwear is recommended. Wear protective hair covering to contain long hair.
- DO NOT USE THE MACHINE IN A DANGEROUS ENVIRONMENT.** The use of power tools in damp or wet locations or in rain can cause shock or electrocution. Keep your work area well-lit to prevent tripping or placing arms, hands, and fingers in danger.
- MAINTAIN ALL TOOLS AND MACHINES IN PEAK CONDITION.** Keep tools sharp and clean for best and safest performance. Follow instructions for lubricating and changing accessories. Poorly maintained tools and machines can further damage the tool or machine and/or cause injury.
- CHECK FOR DAMAGED PARTS.** Before using the machine, check for any damaged parts. Check for alignment of moving parts, binding of moving parts, breakage of parts, and any other conditions that may affect its operation. A guard or any other part that is damaged **should be properly repaired or replaced.** Damaged parts can cause further damage to the machine and/or injury.
- KEEP THE WORK AREA CLEAN.** Cluttered areas and benches invite accidents.
- KEEP CHILDREN AND VISITORS AWAY.** Your shop is a potentially dangerous environment. Children and visitors can be injured.
- REDUCE THE RISK OF UNINTENTIONAL STARTING.** Make sure that the switch is in the "OFF" position before plugging in the power cord. In the event of a power failure, move the switch to the "OFF" position. An accidental start-up can cause injury.
- USE THE GUARDS.** Check to see that all guards are in place, secured, and working correctly to reduce the risk of injury.
- REMOVE ADJUSTING KEYS AND WRENCHES BEFORE STARTING THE MACHINE.** Tools, scrap pieces, and other debris can be thrown at high speed, causing injury.
- USE THE RIGHT MACHINE.** Don't force a machine or an attachment to do a job for which it was not designed. Damage to the machine and/or injury may result.
- USE RECOMMENDED ACCESSORIES.** The use of accessories and attachments not recommended by Delta may cause damage to the machine or injury to the user.
- USE THE PROPER EXTENSION CORD.** Make sure your extension cord is in good condition. When using an extension cord, be sure to use one heavy enough to carry the current your product will draw. An undersized cord will cause a drop in line voltage, resulting in loss of power and overheating. See the Extension Cord Chart for the correct size depending on the cord length and nameplate ampere rating. If in doubt, use the next heavier gauge. The smaller the gauge number, the heavier the cord.
- SECURE THE WORKPIECE.** Use clamps or a vise to hold the workpiece when practical. Loss of control of a workpiece can cause injury.
- FEED THE WORKPIECE AGAINST THE DIRECTION OF THE ROTATION OF THE BLADE, CUTTER, OR ABRASIVE SURFACE.** Feeding it from the other direction will cause the workpiece to be thrown out at high speed.
- DON'T FORCE THE WORKPIECE ON THE MACHINE.** Damage to the machine and/or injury may result.
- DON'T OVERREACH.** Loss of balance can make you fall into a working machine, causing injury.
- NEVER STAND ON THE MACHINE.** Injury could occur if the tool tips, or if you accidentally contact the cutting tool.
- NEVER LEAVE THE MACHINE RUNNING UNATTENDED. TURN THE POWER OFF.** Don't leave the machine until it comes to a complete stop. A child or visitor could be injured.
- TURN THE MACHINE "OFF", AND DISCONNECT THE MACHINE FROM THE POWER SOURCE** before installing or removing accessories, before adjusting or changing set-ups, or when making repairs. An accidental start-up can cause injury.
- MAKE YOUR WORKSHOP CHILDPROOF WITH PADLOCKS, MASTER SWITCHES, OR BY REMOVING STARTER KEYS.** The accidental start-up of a machine by a child or visitor could cause injury.
- STAY ALERT, WATCH WHAT YOU ARE DOING, AND USE COMMON SENSE. DO NOT USE THE MACHINE WHEN YOU ARE TIRED OR UNDER THE INFLUENCE OF DRUGS, ALCOHOL, OR MEDICATION.** A moment of inattention while operating power tools may result in injury.
- ⚠ WARNING USE OF THIS TOOL CAN GENERATE AND DISBURSE DUST OR OTHER AIRBORNE PARTICLES, INCLUDING WOOD DUST, CRYSTALLINE SILICA DUST AND ASBESTOS DUST.** Direct particles away from face and body. Always operate tool in well ventilated area and provide for proper dust removal. Use dust collection system wherever possible. Exposure to the dust may cause serious and permanent respiratory or other injury, including silicosis (a serious lung disease), cancer, and death. Avoid breathing the dust, and avoid prolonged contact with dust. Allowing dust to get into your mouth or eyes, or lay on your skin may promote absorption of harmful material. Always use properly fitting NIOSH/OSHA approved respiratory protection appropriate for the dust exposure, and wash exposed areas with soap and water.

# ADDITIONAL SPECIFIC SAFETY RULES

**▲ WARNING** FAILURE TO FOLLOW THESE RULES MAY RESULT IN SERIOUS PERSONAL INJURY.

1. **DO NOT OPERATE THIS MACHINE UNTIL** it is assembled and installed according to the instructions.
2. **OBTAIN ADVICE** from your supervisor, instructor, or another qualified person if you are not familiar with the operation of this machine.
3. **FOLLOW ALL WIRING CODES** and recommended electrical connections.
4. **MOUNT THE TOOL SECURELY** to a stable supporting surface prior to operation
5. **USE THE GUARDS WHENEVER POSSIBLE.** Check to see that they are in place, secured, and working correctly.
6. **USE ONLY CROSSCUT SAW BLADES.** Use only zero-degree or negative hook angles when using carbide-tipped blades. Do not use blades with deep gullets. These can deflect and contact the guard.
7. **USE ONLY BLADES OF THE CORRECT SIZE AND TYPE** specified for this tool.
8. **USE A SHARP BLADE.** Check blade to see if it runs freely and is free from vibration.
9. **INSPECT BLADE FOR CRACKS** or other damage prior to operation. Replace cracked or damaged blade immediately.
10. **CLEAN THE BLADE AND BLADE FLANGES** prior to operation. Check for any damage and tighten the arbor nut securely.
11. **USE ONLY BLADE FLANGES** specified for this tool.
12. **CLEAR THE AREA OF FLAMMABLE LIQUIDS** and/or gas prior to operation.
13. **CLEAN THE MOTOR AIR SLOTS** of chips and sawdust.
14. **TIGHTEN THE TABLE CLAMP HANDLE** and any other clamps prior to operation.
15. **NEVER START THE TOOL** with the workpiece against the blade.
16. **KEEP HANDS out of path** of saw blade. Clamp all workpieces that would require your hand to be in the "Table Hazard Zone" (within the red lines).
17. **ALLOW THE MOTOR to come to full speed** prior to starting cut.
18. **NEVER REACH AROUND** or behind the saw blade.
19. **NEVER CUT FERROUS METALS** or masonry.
20. **NEVER RECUT SMALL PIECES.**
21. **NEVER LOCK THE SWITCH** in the "ON" position.
22. **NEVER APPLY LUBRICANT** to a running blade.
23. **DO NOT PERFORM FREE-HAND OPERATIONS.** Hold the work firmly against the fence and table. Use clamps to hold the work when possible.
24. **PROPERLY SUPPORT LONG or wide workpieces.**
25. **AFTER COMPLETING CUT,** release power switch and wait for coasting blade to come to a complete stop before returning saw to raised position.
26. **TURN OFF TOOL AND ALLOW THE BLADE TO COME TO A COMPLETE STOP** prior to cleaning the blade area or removing debris in the path of the blade. A coasting blade can be dangerous.
27. **TURN OFF TOOL AND ALLOW BLADE TO COME TO A COMPLETE STOP** before removing or securing workpiece, changing workpiece angle, or changing the angle of the blade.
28. **NEVER PERFORM LAYOUT, ASSEMBLY,** or set-up work on the table/work area when the machine is running.
29. **TURN THE MACHINE "OFF" AND DISCONNECT THE MACHINE** from the power source before installing or removing accessories, before adjusting or changing set-ups, or when making repairs.
30. **TURN THE MACHINE "OFF",** disconnect the machine from the power source, and clean the table/work area before leaving the machine. **LOCK THE SWITCH IN THE "OFF" POSITION** to prevent unauthorized use.
31. **ADDITIONAL INFORMATION** regarding the safe and proper operation of this tool is available from the Power Tool Institute, 1300 Summer Avenue, Cleveland, OH 44115-2851. Information is also available from the National Safety Council, 1121 Spring Lake Drive, Itasca, IL 60143-3201. Please refer to the American National Standards Institute ANSI 01.1 Safety Requirements for Woodworking Machines and the U.S. Department of Labor OSHA 1910.213 Regulations.

## POWER CONNECTIONS

A separate electrical circuit should be used for your machines. This circuit should not be less than #12 wire and should be protected with a 20 Amp time lag fuse. If an extension cord is used, use only 3-wire extension cords which have 3-prong grounding type plugs and matching receptacle which will accept the machine's plug. Before connecting the machine to the power line, make sure the switch (s) is in the "OFF" position and be sure that the electric current is of the same characteristics as indicated on the machine. All line connections should make good contact. Running on low voltage will damage the machine.

**⚠ DANGER DO NOT EXPOSE THE MACHINE TO RAIN OR OPERATE THE MACHINE IN DAMP LOCATIONS.**

## MOTOR SPECIFICATIONS

Your machine is wired for 120V, 60 HZ alternating current. Before connecting the machine to the power source, make sure the switch is in the "OFF" position.

## GROUNDING INSTRUCTIONS

**⚠ DANGER THIS MACHINE MUST BE GROUNDED WHILE IN USE TO PROTECT THE OPERATOR FROM ELECTRIC SHOCK.**

### 1. All grounded, cord-connected machines:

In the event of a malfunction or breakdown, grounding provides a path of least resistance for electric current to reduce the risk of electric shock. This machine is equipped with an electric cord having an equipment-grounding conductor and a grounding plug. The plug must be plugged into a matching outlet that is properly installed and grounded in accordance with all local codes and ordinances.

Do not modify the plug provided - if it will not fit the outlet, have the proper outlet installed by a qualified electrician.

Improper connection of the equipment-grounding conductor can result in risk of electric shock. The conductor with insulation having an outer surface that is green with or without yellow stripes is the equipment-grounding conductor. If repair or replacement of the electric cord or plug is necessary, do not connect the equipment-grounding conductor to a live terminal.

Check with a qualified electrician or service personnel if the grounding instructions are not completely understood, or if in doubt as to whether the machine is properly grounded.

Use only 3-wire extension cords that have 3-prong grounding type plugs and matching 3-conductor receptacles that accept the machine's plug, as shown in Fig. A.

Repair or replace damaged or worn cord immediately.

### 2. Grounded, cord-connected machines intended for use on a supply circuit having a nominal rating less than 150 volts:

If the machine is intended for use on a circuit that has an outlet that looks like the one illustrated in Fig. A, the machine will have a grounding plug that looks like the plug illustrated in Fig. A. A temporary adapter, which looks like the adapter illustrated in Fig. B, may be used to connect this plug to a matching 2-conductor receptacle as shown in Fig. B if a properly grounded outlet is not available. The temporary adapter should be used only until a properly grounded outlet can be installed by a qualified electrician. The green-colored rigid ear, lug, and the like, extending from the adapter must be connected to a permanent ground such as a properly grounded outlet box. Whenever the adapter is used, it must be held in place with a metal screw.

**NOTE: In Canada, the use of a temporary adapter is not permitted by the Canadian Electric Code.**

**⚠ DANGER IN ALL CASES, MAKE CERTAIN THE RECEPTACLE IN QUESTION IS PROPERLY GROUNDED. IF YOU ARE NOT SURE HAVE A QUALIFIED ELECTRICIAN CHECK THE RECEPTACLE.**

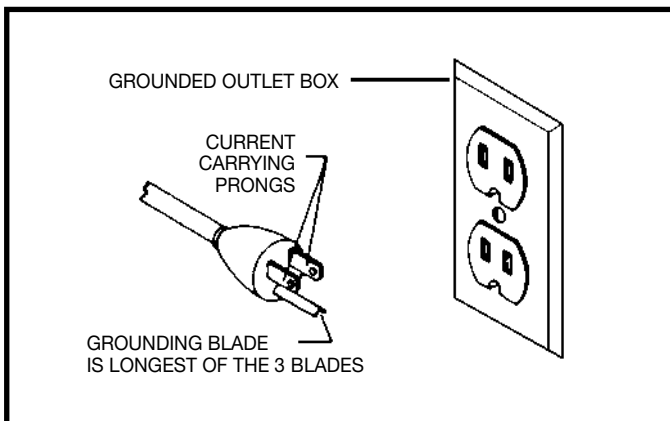

Fig. A

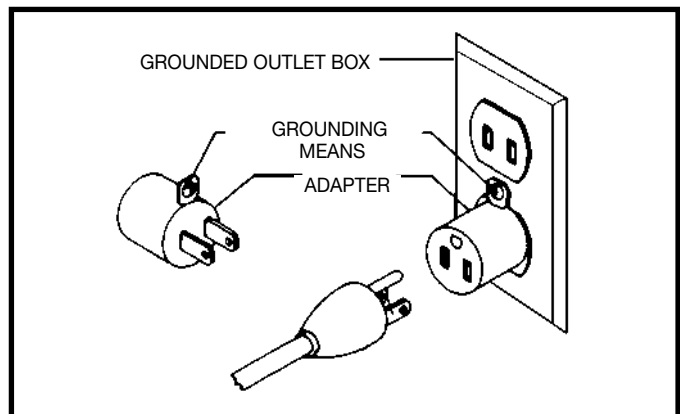

Fig. B



## EXTENSION CORDS

**⚠ WARNING** Use proper extension cords. Make sure your extension cord is in good condition and is a 3-wire extension cord which has a 3-prong grounding type plug and matching receptacle which will accept the machine's plug. When using an extension cord, be sure to use one heavy enough to carry the current of the machine. An undersized cord will cause a drop in line voltage, resulting in loss of power and overheating. Fig. D shows the correct gauge to use depending on the cord length. If in doubt, use the next heavier gauge. The smaller the gauge number, the heavier the cord.

MINIMUM GAUGE EXTENSION CORD			
RECOMMENDED SIZES FOR USE WITH STATIONARY ELECTRIC MACHINES			
Ampere Rating	Volts	Total Length of Cord in Feet	Gauge of Extension Cord
0-6	120	up to 25	18 AWG
0-6	120	25-50	16 AWG
0-6	120	50-100	16 AWG
0-6	120	100-150	14 AWG
6-10	120	up to 25	18 AWG
6-10	120	25-50	16 AWG
6-10	120	50-100	14 AWG
6-10	120	100-150	12 AWG
10-12	120	up to 25	16 AWG
10-12	120	25-50	16 AWG
10-12	120	50-100	14 AWG
10-12	120	100-150	12 AWG
12-16	120	up to 25	14 AWG
12-16	120	25-50	12 AWG
12-16	120	GREATER THAN 50 FEET NOT RECOMMENDED	

Fig. D

## FUNCTIONAL DESCRIPTION

### FOREWORD

Delta ShopMaster Model MS275 is a 10" Compound Power Miter Saw designed to cut wood, plastic, and aluminum. Compound angle and bevel cutting are easy and accurate. It can crosscut up to 5-5/8" x 2-3/4", miter at 45° both left and right 4" x 2-3/4", bevel at 45° left 1-5/8" x 5-5/8", and compound 45° x 45°, 4" x 1-5/8". It has trigger-controlled indexing with positive miter stops at 0°, 15.5°, 22.5°, 30°, and 45° both left and right, and bevel stops at 0° and 45° left.

**NOTICE: THE PHOTO ON THE MANUAL COVER ILLUSTRATES THE CURRENT PRODUCTION MODEL. ALL OTHER ILLUSTRATIONS CONTAINED IN THE MANUAL ARE REPRESENTATIVE ONLY AND MAY NOT DEPICT THE ACTUAL COLOR, LABELING OR ACCESSORIES AND ARE INTENDED TO ILLUSTRATE TECHNIQUE ONLY.**

## CARTON CONTENTS

Remove the miter saw and all loose items from the carton.

### CAUTION

**LIFTING THE MITER SAW BY THE SWITCH HANDLE CAN CAUSE MISALIGNMENT. ALWAYS LIFT THE MACHINE BY THE BASE OR THE CARRYING HANDLE (SEE FIG. 8)**

1. Miter Saw
2. Work Clamp
3. Table Extension Wings (2)
4. Blade Wrench
5. Hex wrench
6. Dust Bag
7. Dust Spout
8. Panhead screw (not shown)

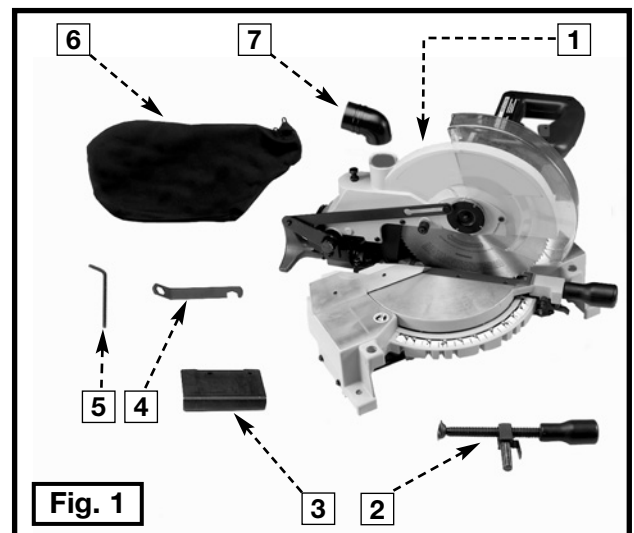

Fig. 1

## UNPACKING AND CLEANING

Carefully unpack the machine and all loose items from the shipping container(s). Remove the protective coating from all unpainted surfaces. This coating may be removed with a soft cloth moistened with kerosene (do not use acetone, gasoline or lacquer thinner for this purpose). After cleaning, cover the unpainted surfaces with a good quality household floor paste wax.

## ASSEMBLY

### ASSEMBLY TOOLS REQUIRED

\* Phillips head screwdriver (not supplied)

### ASSEMBLY TIME ESTIMATE - 15 to 30 minutes

**⚠ WARNING** For your own safety, do not connect the machine to the power source until the machine is completely assembled and you read and understand the entire instruction manual.

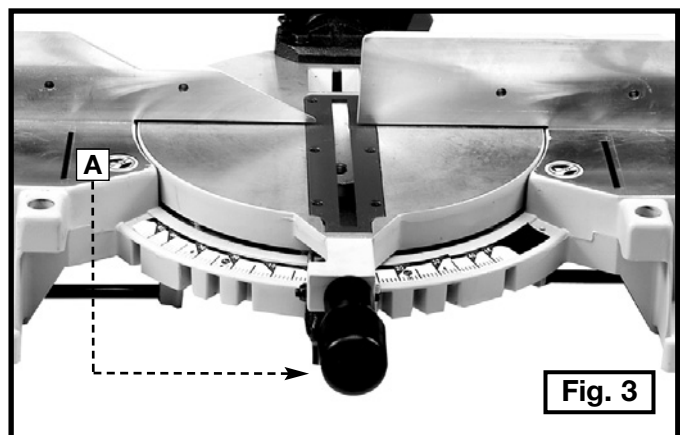
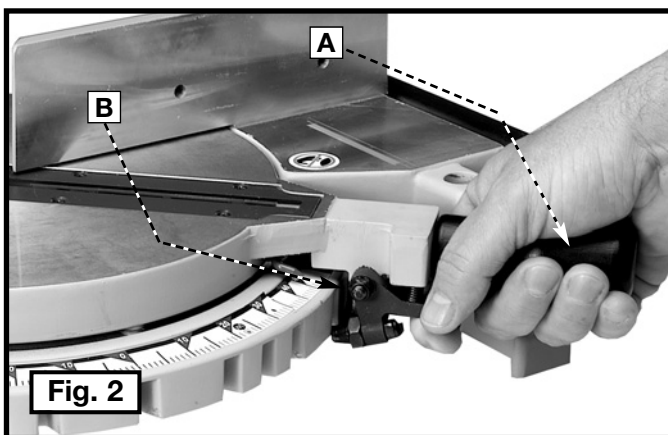

### ROTATING THE TABLE

Loosen the table-lock handle (A) Fig. 2 one or two turns. Raise the index lever (B) Fig. 2 and rotate the table to the desired position. Tighten the table-lock handle (A) Fig. 3.

### MOVING THE CUTTINGHEAD TO THE "UP" POSITION

**⚠ WARNING** DISCONNECT THE MACHINE FROM THE POWER SOURCE.

1. Push the switch handle (A) down and pull out the cuttinghead lock knob (B).
2. Move the cuttinghead (C) to the up position.
3. To lock the cuttinghead in the "down" position, reverse the procedure.

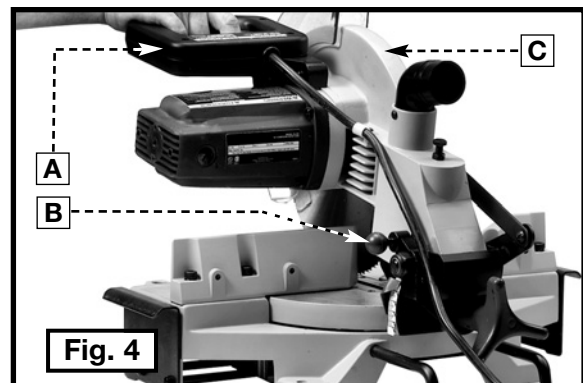



## FASTENING THE MACHINE TO THE SUPPORTING SURFACE

Before operating your compound miter saw, mount it to a sturdy workbench or other supporting surface. Four holes are provided, two of which are shown at (A) Fig. 5.

When frequently moving the saw from place to place, mount the saw to a 3/4" piece of plywood. The tool can then be easily moved from place to place and the plywood can be clamped to a supporting surface using "C" clamps.

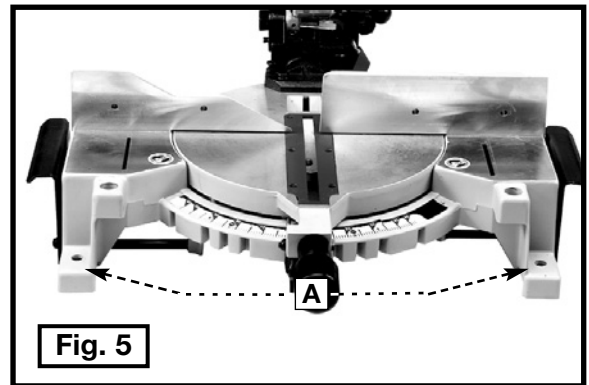

## REAR SUPPORT/STABILIZER & CARRYING HANDLE

**⚠ WARNING** Keep the rear support (A) Fig. 6 fully extended during all cutting operations. Push the rear support in only when storing the machine.

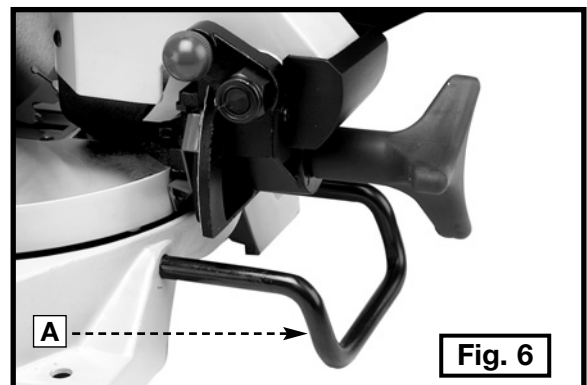

Use the rear support/stabilizer and carrying handle (A) Fig. 7 to carry the machine.

**CAUTION** Carrying the machine by the switch handle will cause misalignment. Always lift and carry the machine by the base or by the carrying handle (A) Fig. 7.

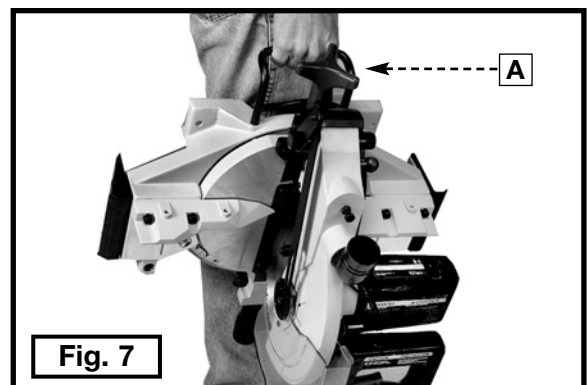

## TABLE EXTENSION WINGS

This machine uses two table extension wings to help stabilize the machine, and to help support long or wide workpieces. To attach the table extension wings:

Remove the screws on the ends of the extension rods (A) Fig. 8. Attach the table extension wings (A) Fig. 9 to the extension rods and secure with the screws just removed. To utilize the supports, pull them out to their full length (Fig. 10).

## DUST BAG

Insert the dust spout (A) Fig. 11 in the exhaust (B) with the ridges in the up position. Secure with the supplied panhead screw. Depress the dust bag spring clips (C) Fig. 11, and secure the dust bag spring clips (D) between the ridges on the spout (A).

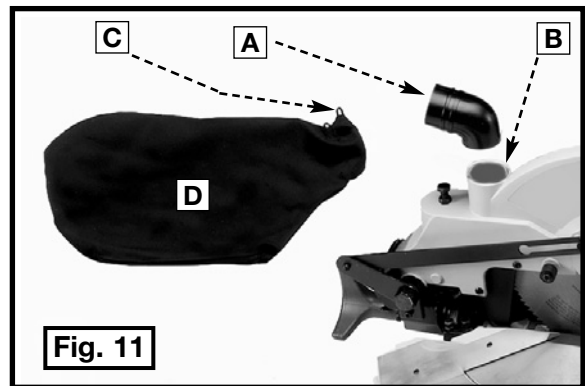
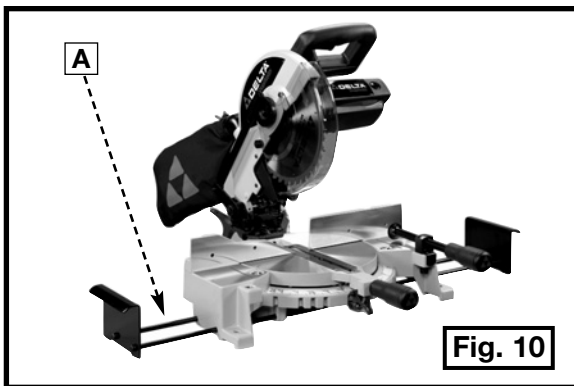
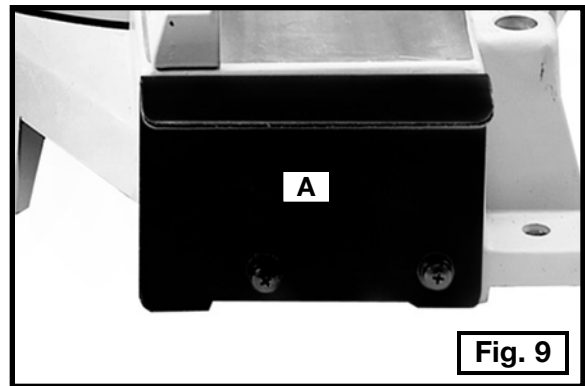
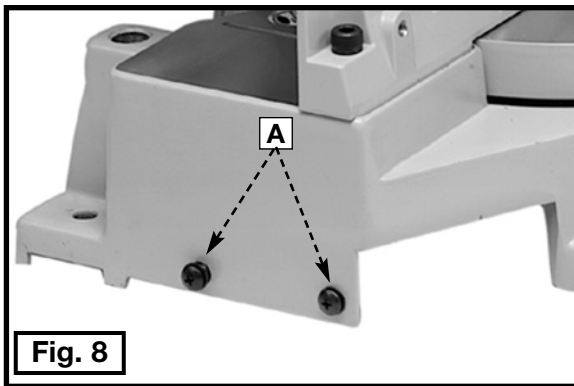

## WORK CLAMP

Some Delta miter saws come with a work clamp (A) Fig. 12. If your machine has a work clamp, you can position it in one of two holes (A) Fig. 13 in the left or right side of the base. Use this clamp, especially with short workpieces (B) Fig. 12.

**⚠ WARNING** Keep your hands out of the path of the saw blade. If necessary, clamp the workpiece in place before making the cut.

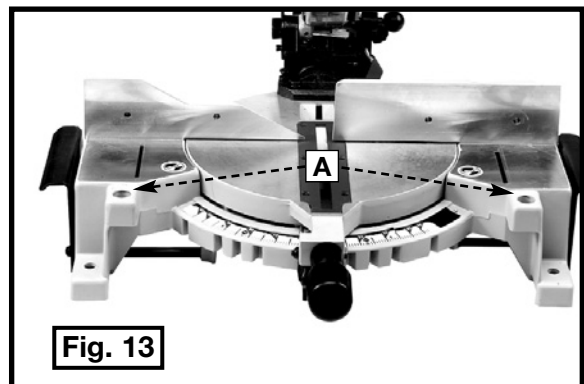
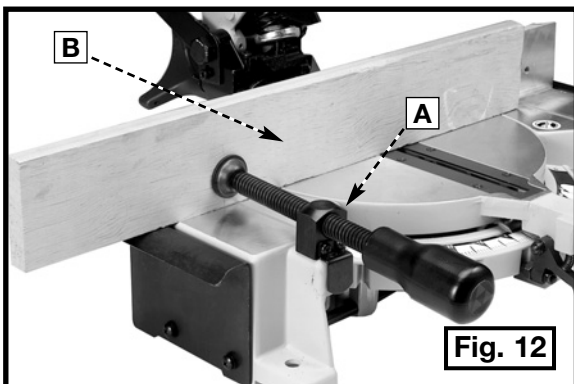

# OPERATION

## OPERATIONAL CONTROLS AND ADJUSTMENTS

### STARTING AND STOPPING THE MITER SAW



To start the miter saw, depress the switch trigger (A) Fig. 14. To stop the miter saw, release the switch trigger. This saw is equipped with an automatic electric blade brake. As soon as the switch trigger (A) Fig. 14 is released, the electric brake activates and stops the blade in seconds.

**⚠ WARNING** A TURNING SAW BLADE CAN BE DANGEROUS. AFTER COMPLETING THE CUT, RELEASE THE SWITCH TRIGGER (A) FIG. 14 TO ACTIVATE THE BLADE BRAKE. KEEP THE CUTTINGHEAD DOWN UNTIL THE BLADE HAS COME TO A COMPLETE STOP.

**⚠ WARNING** THE TORQUE DEVELOPED DURING BRAKING MAY LOOSEN THE ARBOR SCREW. CHECK THE ARBOR SCREW PERIODICALLY AND TIGHTEN IF NECESSARY.

### LOCKING THE SWITCH IN THE “OFF” POSITION

**IMPORTANT:** When the miter saw is not in use, lock the switch in the “OFF” position, using a padlock (B) Fig. 15 with a 3/16" diameter shackle to prevent unauthorized use of the saw.

### POINTER AND SCALE

A pointer (A) Fig. 16 is supplied to indicate the actual angle of cut. Each line on the scale (B) represents 1 degree. When the pointer is moved from one line to the next on the scale, the angle of cut is changed by 1 degree.

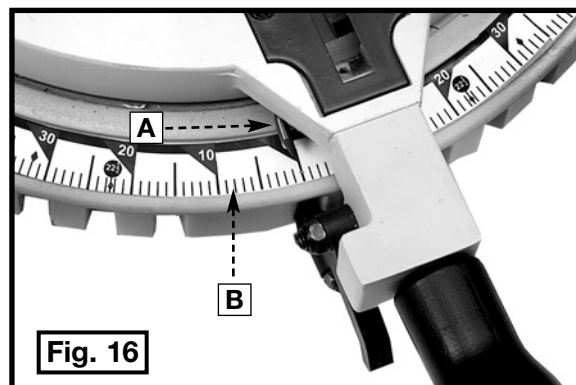

### ROTATING THE TABLE FOR MITER CUTTING

Your miter saw will cut any angle from a straight 90° cut to 47° right and left. Loosen the lock handle (A) Fig. 17 one or two turns, depress the index lever (B), and move the control arm to the desired angle. **TIGHTEN THE LOCK HANDLE (A)**. The miter saw is equipped with positive stops at the 0°, 15.5, 22.5°, 31.62°, and 45° right and left positions. Loosen the lock handle (A) Fig. 17, and move the control arm until the bottom of the index lever (B) engages into one of the positive stops (C) Fig. 17. **TIGHTEN THE LOCK HANDLE (A) Fig. 17**. To disengage the positive stop, depress the index lever (B).

Additionally, a triangle indicator and positive stop are provided on the miter scale at the 31.62° right and left miter positions (D) Fig.18 for cutting crown moulding. (Refer to the “**CUTTING CROWN MOULDING**” section of this manual).

**IMPORTANT:** Always tighten the lock handle (A) Fig. 17 before cutting.

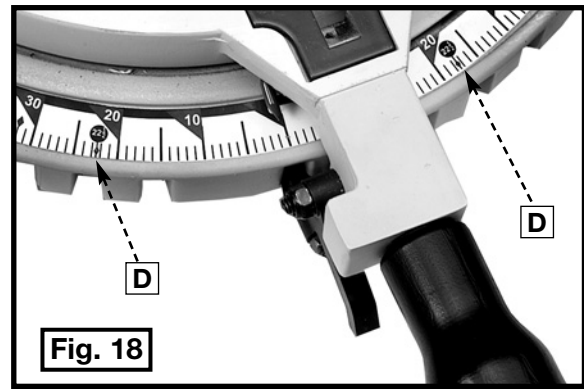
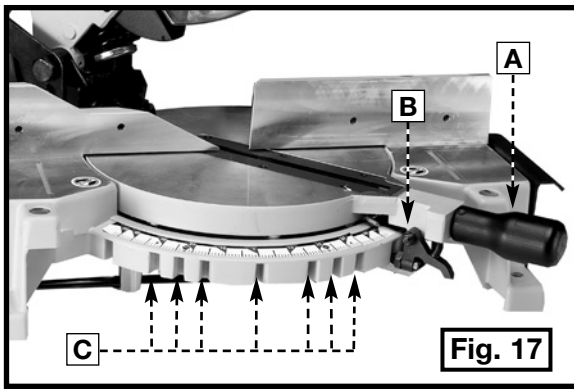

## TILTING THE CUTTINGHEAD FOR BEVEL CUTTING

The cuttinghead of your compound miter saw can be tilted to cut any bevel angle from a 90° straight cut off to a 45° left bevel angle. Loosen bevel lock handle (A) Fig. 19, tilt the cutting arm to the desired angle, and tighten the lock handle (A).

Positive stops are provided to rapidly position the saw blade at 90° and 45° to the table. Refer to the section of this manual titled “**ADJUSTING 90° AND 45° DEGREE BEVEL STOPS.**” The bevel angle of the cutting arm is determined by the position of the pointer (B) Fig. 19 on the scale (C).

In addition, a triangle indicator is provided on the bevel scale for cutting crown moulding. Refer to the “**CUTTING CROWN MOULDING**” section of this manual.

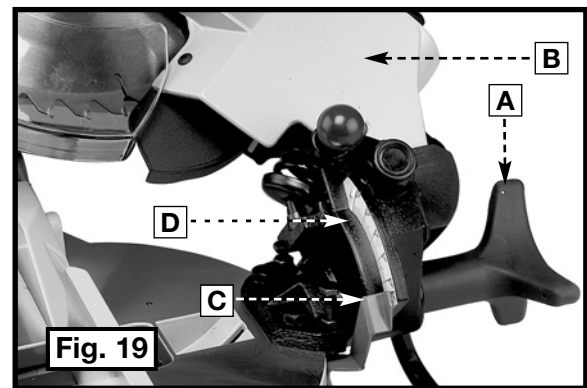

**⚠ WARNING** ALWAYS tighten the bevel lock handle (A) FIG. 19 securely before operating the saw.

## ADJUSTING THE DOWNWARD TRAVEL OF THE SAW BLADE

**⚠ WARNING** DISCONNECT THE MACHINE FROM THE POWER SOURCE.

1. The downward travel of the saw blade should be limited to prevent the saw blade from contacting any metal surfaces of the machine. This adjustment is made by loosening the locknut (A) Fig. 20, and turning the adjusting screw (B) in or out.
2. Lower the blade as far as possible. Rotate the blade by hand to ensure that the teeth do not contact any metal surfaces. Adjust if necessary.
3. After the downward travel of the saw blade has been adjusted, tighten the locknut (A)

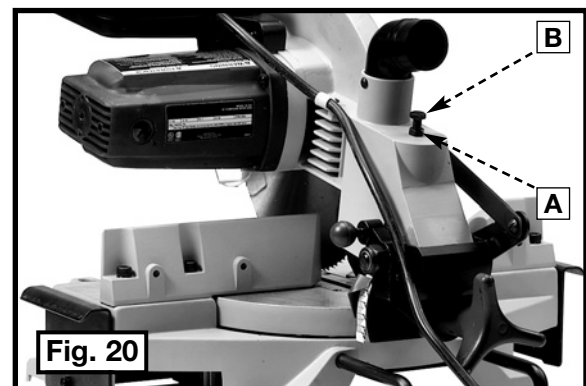



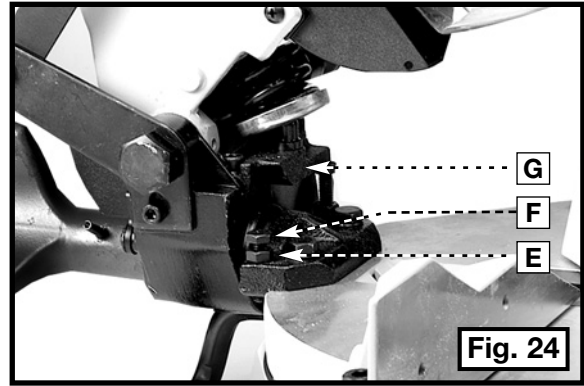
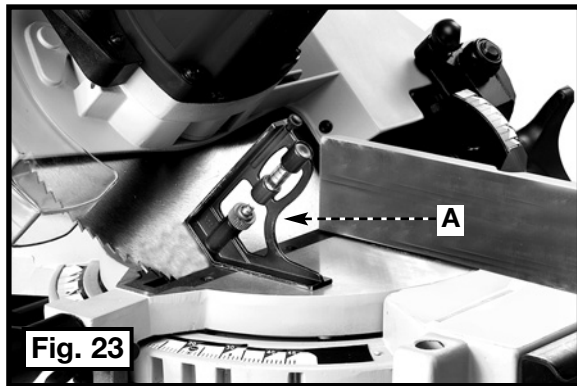
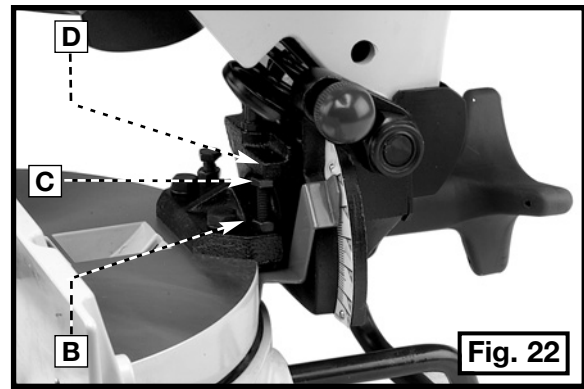
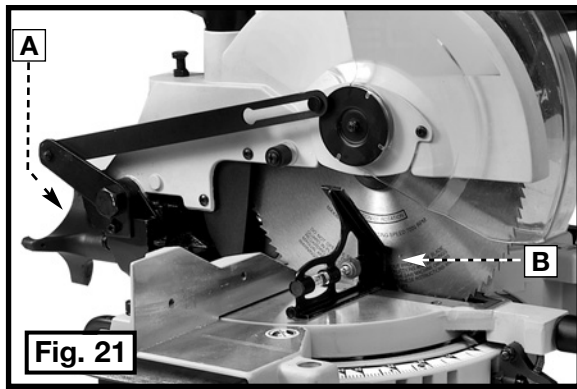

## ADJUSTING THE 90° AND 45° BEVEL STOPS

**⚠ WARNING** DISCONNECT THE MACHINE FROM THE POWER SOURCE.

1. Lock the machine in the “down” position (Fig. 21).
2. Place one end of a square (B) Fig. 21 on the table and the other end against the blade. Check to see if the blade is 90° to the table.
3. If an adjustment is necessary, loosen the locknut (B) Fig. 22. Turn the screw (C) until the head of the screw contacts the casting (D) when the blade is 90° to the table. Tighten the locknut (B).
4. Raise the cuttinghead. Loosen the bevel lock handle (A) Fig. 21.
5. Move the cuttinghead all the way to the left bevel position and tighten the bevel lock handle.
6. Use a combination square (A) Fig. 23 to see if the blade is at 45° to the table.
7. If an adjustment is necessary, loosen the locknut (E) Fig. 24. Turn the screw (F) until the screw (F) contacts the casting (G) when the blade is 45 degrees to the table. Tighten the locknut (E).

## ADJUSTING THE TABLE POSITIVE STOPS

**⚠ WARNING** DISCONNECT THE MACHINE FROM THE POWER SOURCE.

1. Place a straight edge (D) Fig. 25 against both fences to determine if the two fence halves are parallel. To adjust, loosen fence mounting screws, two of which are shown at (H) and make the required adjustments. Tighten fence mounting screws.

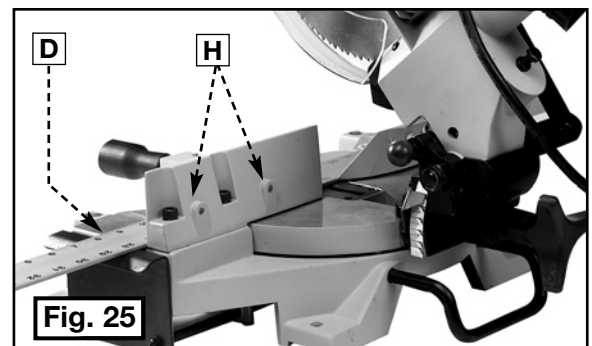

**NOTE:** Check to see that the blade is 90 degrees to the fence.

2. Move the table to the 90 degree straight cut-off position. Make sure that the bottom of the index lever (C) Fig. 28 is engaged in the 0 degree positive stop. Tighten the lock handle (D) Fig. 28.
3. Clamp the workpiece and make a cut (Fig. 26).
4. Use a square to see if the piece of wood was cut at 90° (Fig. 27).
5. To adjust, loosen the lock handle (D) Fig. 28 one turn. Loosen the locknut (B) and turn eccentric nut (C) right or left. Tighten the lock nut (B).
6. Make a test cut after each adjustment.
7. When the cut is 90°, loosen the set screw (E) Fig. 28 and adjust the pointer (D) to point to the "0" mark on the scale.
8. Adjustment of the 90 degree positive stop ensures the correct adjustment of the other positive stops.

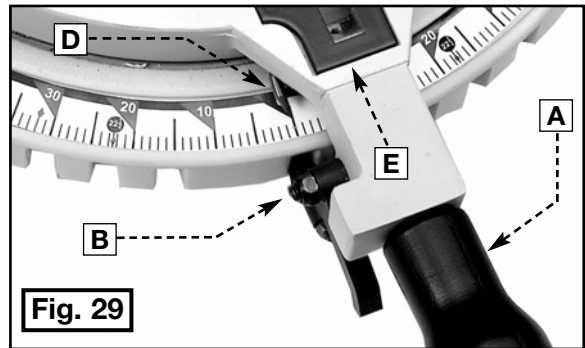
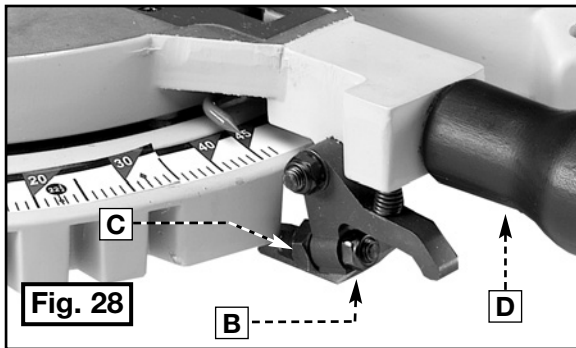
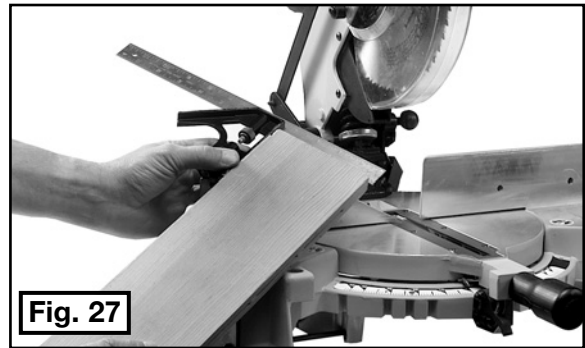

## MACHINE USE

### HAZARD ZONE

**⚠ WARNING** The area inside the two red lines (A) Fig. 30 is designated as a "HAZARD ZONE". Never place your hands inside this area while the machine is running.

### HELPFUL HINTS

1. Before cutting, check to see that the cuttinghead and table are at the correct settings and are firmly locked in place.
2. Place the workpiece on the table and hold or clamp it firmly against the fence with the work clamp (A) Fig. 12. This clamp can be used on either the left or right side of the machine (See Fig. 13).
3. Cut at a slow, even cutting rate.

**⚠ WARNING** If the position or size of the workpiece causes your hand to be in the "Hazard Zone", use the work clamp to secure the workpiece. **Never place your hands inside this area while the machine is running.**

**⚠ WARNING** Never attempt freehand cutting (wood that is not held or clamped firmly against the fence and table).

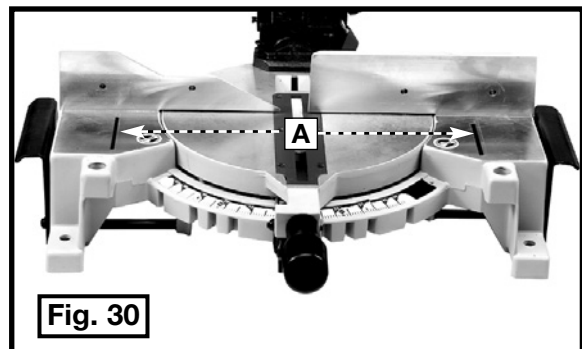



## AUXILIARY WOOD FENCE

**⚠ WARNING** When performing multiple or repetitive operations that result in small cut-off pieces (one inch or less), the saw blade can catch the cut-off pieces and project them out of the machine or into the blade guard and housing, causing damage or injury. To limit the risk, mount an auxiliary wood fence on your saw (Fig. 31).

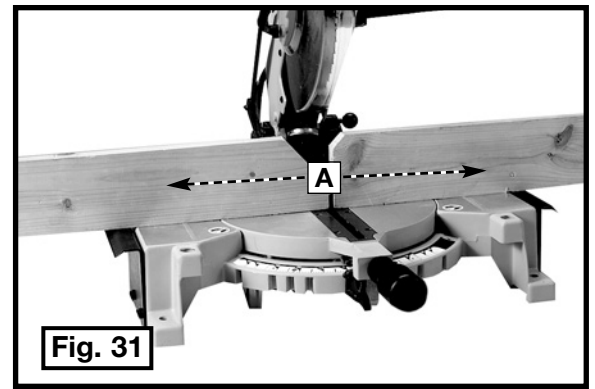

## WORK SUPPORT EXTENSIONS

For support when cutting long pieces, construct a work support extension. Fig. 32 illustrates the miter saw mounted on two standard 2 x 4's (A). Fasten the four mounting legs (two of which are shown at (B) Fig. 32) to the 2 x 4's, using four screws (not supplied) through the four holes in the mounting legs. The length of the 2 x 4's (A) can vary, depending on the workpiece.

**NOTE:** Ensure that the top of the support 2 x 4's (C) are level with the miter saw table. This is critical because the distance from the top of the 2 x 4's (A) to the miter saw table varies from saw to saw. In most cases, standard 2 x 4's (C) can be used. If these are too high, cut them to fit. If the 2 x 4's are too low, use 2 x 6's. If these are high, cut them to the correct height.

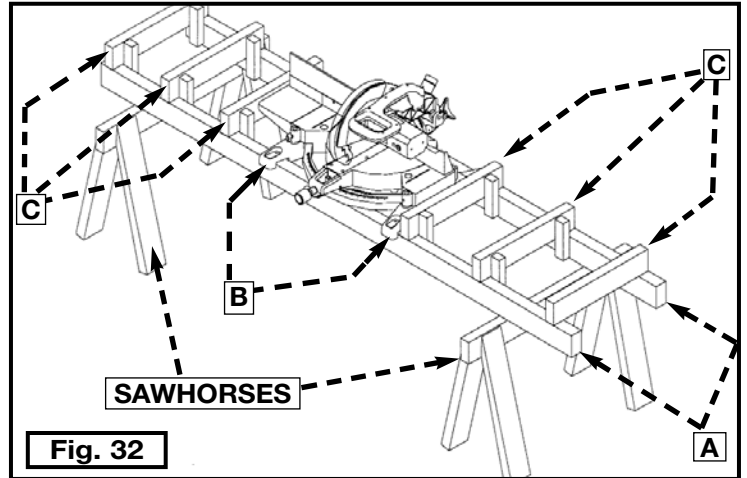

## CUTTING BOWED MATERIAL

When cutting flat pieces, first check to see if the material is bowed. If it is, position the material on the table as shown in Fig. 41.

If the material is positioned the wrong way as shown in Fig. 42, the workpiece will pinch the blade near the completion of the cut.

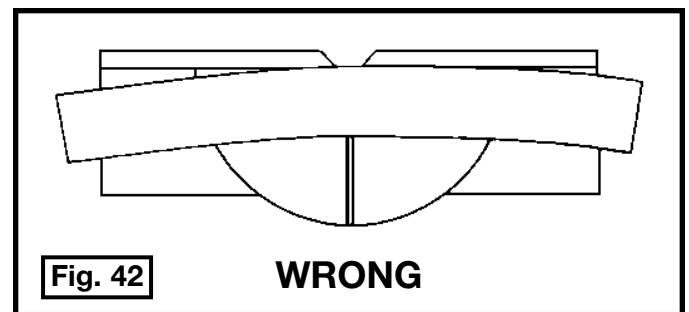
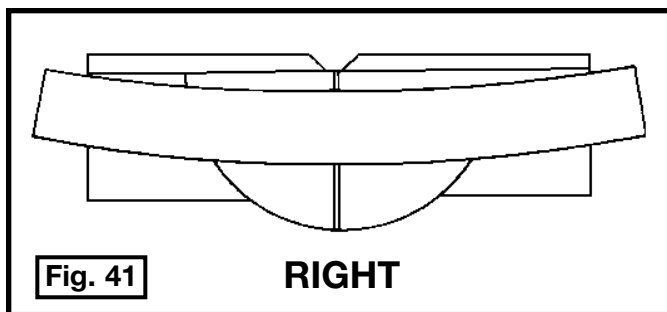

## GENERAL CUTTING OPERATIONS

Your machine can cut:

1. standard 2 x 4's lying flat or on edge at 45° right and left miter angles (Figs. 33 and 34).
2. standard 2 x 6's in the 90° straight cut-off position in
3. one pass (Fig. 35).
4. standard 4 x 4's in one pass (Fig. 36).
5. crown molding and other bevel-type cuts (Fig. 37).
6. various sizes of plastic pipe (Fig. 38).

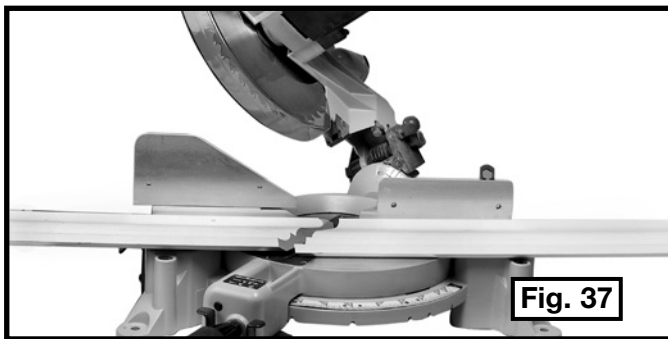
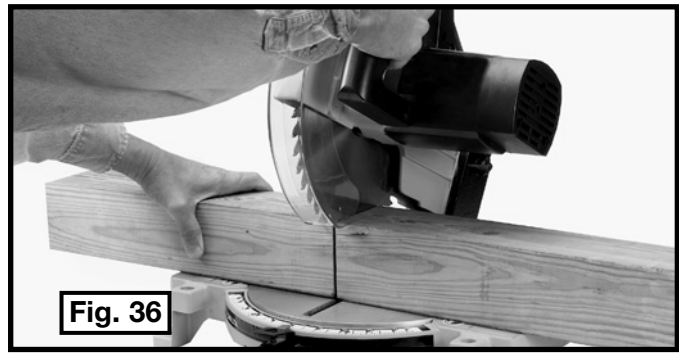
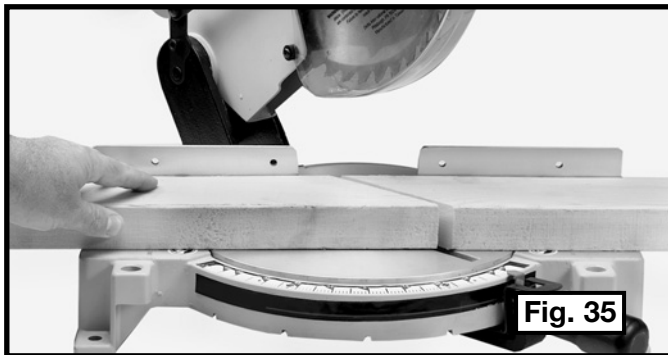
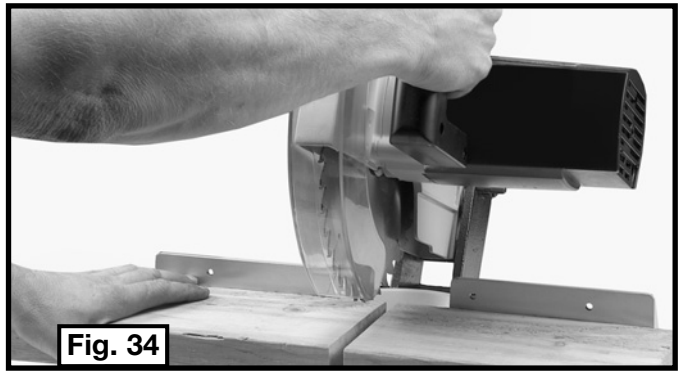
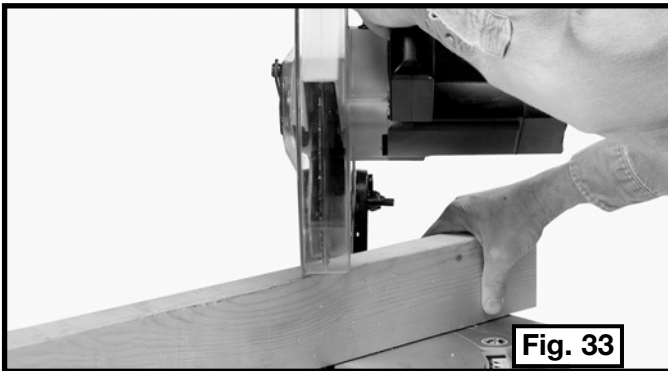

## CUTTING ALUMINUM

You can easily cut aluminum extrusions (for making aluminum screens and storm windows) with your compound miter saw. When cutting aluminum extrusions (or other sections that can be cut with a saw blade), position the material so that the blade is cutting through the smallest cross-section (Fig. 39). The wrong way to cut aluminum angles is illustrated in Fig. 39A. Apply a stick wax (available at most mill supply houses) to the blade before cutting aluminum stock. The wax provides proper lubrication and keeps chips from adhering to the blade.

**⚠ WARNING** Never apply lubricant to the blade while the machine is running.

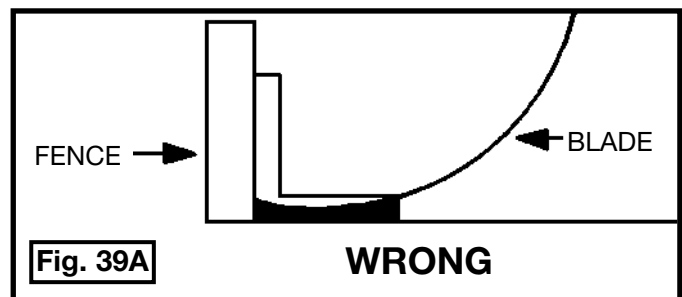
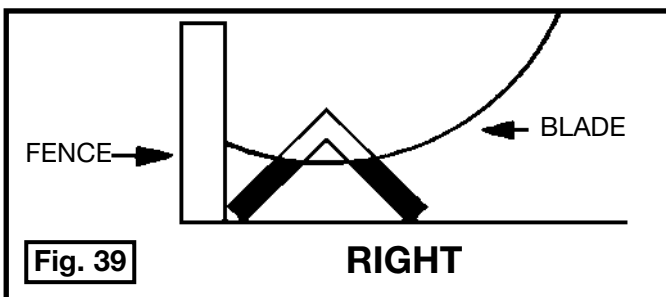

## CUTTING CROWN MOULDING

One of the many features of the saw is the ease of cutting crown moulding. The following is an example of cutting both inside and outside corners on  $52^{\circ}/38^{\circ}$  wall angle crown moulding.

1. Move the table to the  $31.62^{\circ}$  right miter position and lock the table in position. **NOTE:** A positive stop is provided to find this angle quickly.
2. Tilt the saw blade to the  $33.86^{\circ}$  left bevel position and tighten bevel lock handle. **NOTE:** A triangle indicator is provided on the bevel scale to find this angle quickly.
3. Place the crown moulding on the table with the **CEILING EDGE** of the moulding against the fence, and make the cut, as shown in Fig. 40.

**NOTE:** The piece of crown moulding used for the outside corner will always be on the right hand side of the blade, as shown at (A) Fig. 40. The piece of crown moulding used for the inside corner will always be on the left hand side of the blade, as shown at (B) Fig. 40.

4. To make the matching halves of the inside and outside corners, rotate the table to the  $31.62^{\circ}$  left miter position.

**NOTE:** A positive stop is provided to find this angle quickly. The saw blade is already tilted to the  $33.86^{\circ}$  left bevel position from the previous cut.

5. Place the crown moulding on the table with the **WALL EDGE** of the crown moulding against the fence and make the cut. Again, the piece of crown moulding used for the outside corner will always be on the right side of the blade, as shown at (C) Fig. 41. The piece of crown moulding used for the inside corner will always be on the left side of the blade, as shown at (D) Fig. 41.
6. Fig. 42 illustrates the two outside corner pieces; (A) being the piece cut at (A) Fig. 40 and (C) being the piece cut at (C) Fig. 41.
7. Fig. 43 illustrates the two inside corner pieces; (B) being the piece cut at (B) Fig. 40, and (D) being the piece cut at (D) Fig. 41.

## 45-45 CROWN MOULDING

**NOTE:** If you are cutting crown moulding that is  $45^{\circ}-45^{\circ}$ , follow the same procedure above, with the exception that the bevel position will always be at  $30^{\circ}$  and the miter position will be  $35-1/4^{\circ}$  to the right or left.

## OTHER ANGLES

**NOTE:** The above instructions are assuming the angle between the walls is  $90^{\circ}$ . If you need help cutting crown moulding set at angles other than  $90^{\circ}$ , see the instruction sheet "**CUTTING CROWN MOULDING**" on the Delta Machinery web site at [www.deltamachinery.com](http://www.deltamachinery.com).

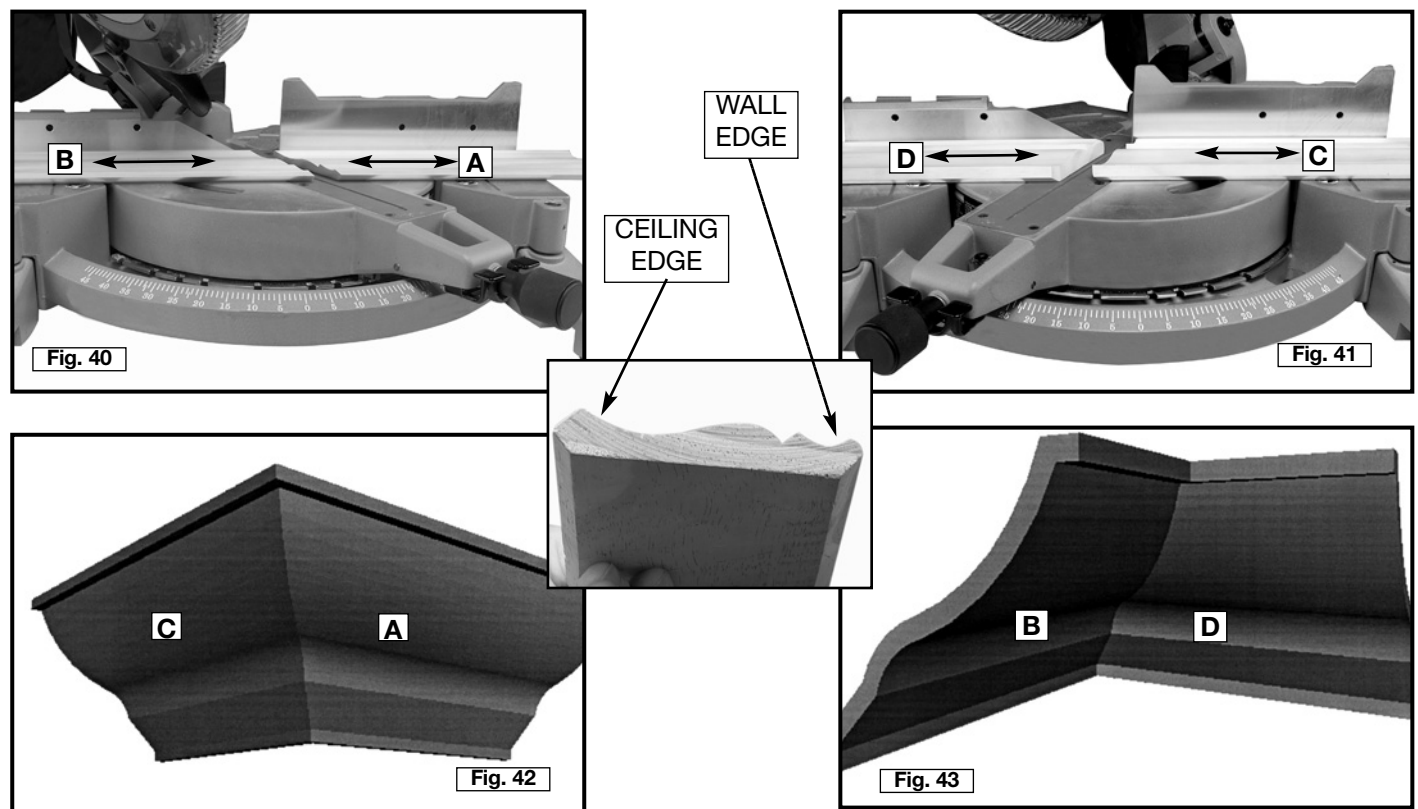

# TROUBLESHOOTING

For assistance with your machine, visit our website at [www.deltamachinery.com](http://www.deltamachinery.com) for a list of service centers or call the DELTA Machinery help line at 1-800-223-7278 (In Canada call 1-800-463-3582).

## MAINTENANCE

### CHANGING THE BLADE

**▲ WARNING** Use only cross-cutting blades.

**▲ WARNING** Do not use carbide-tipped blades with deep gullets. They can deflect and contact the guard.

**▲ WARNING** Use only 10" diameter saw blades that are rated for 5000 RPM or higher and have 5/8" diameter arbor holes.

**▲ WARNING** Disconnect the machine from the power source.

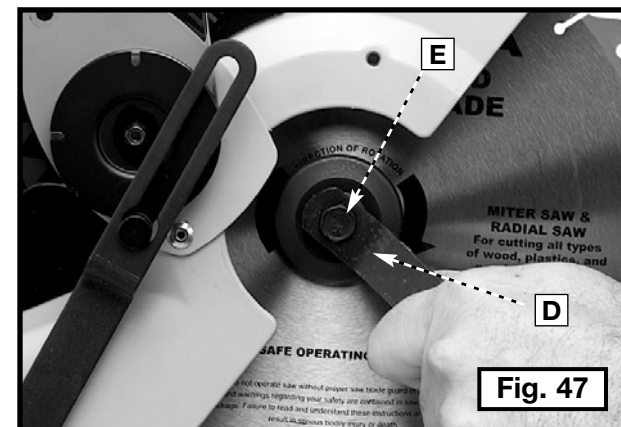
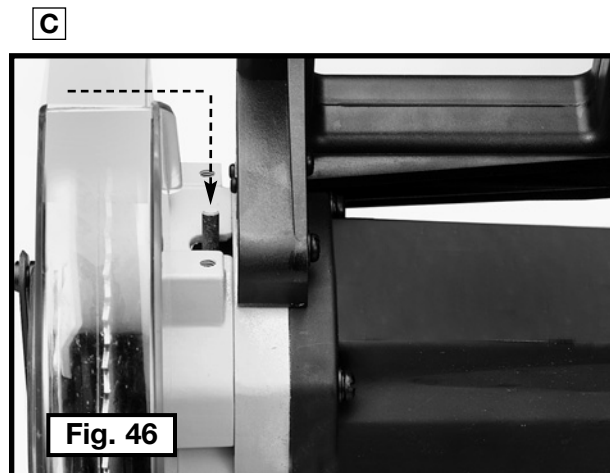
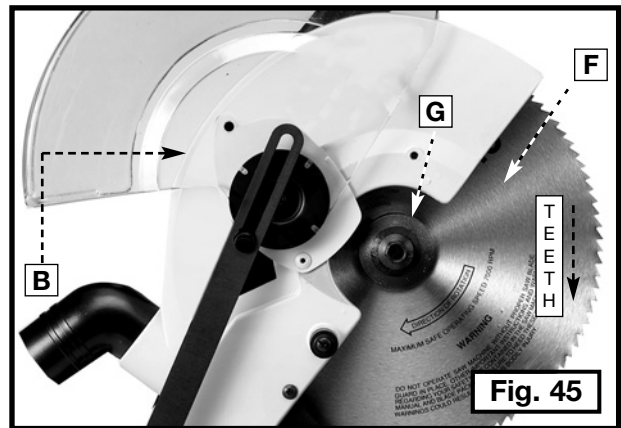
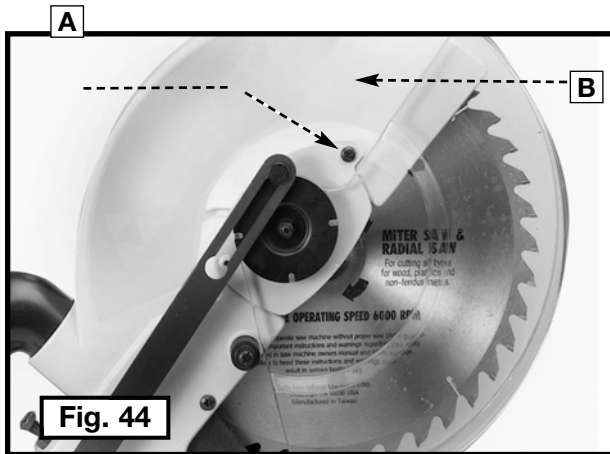

1. Remove the screw (A) Fig. 44 and rotate the cover (B) to the rear (Fig. 45).
2. Press in on the arbor lock (C) Fig. 46 to keep the arbor from turning.
3. Use the supplied wrench (D) Fig. 47 to loosen the arbor screw (E). Turn it clockwise.
4. Remove the arbor screw (E), Fig. 47, outside blade flange (G), Fig. 45, and saw blade (F) Fig. 45 from the saw arbor.
5. Attach a new saw blade.

**▲ WARNING** Make sure that the teeth of the saw blade are pointing down at the front. (See Fig. 48.)

6. Attach the outside blade flange (G) Fig. 45 and arbor screw (E) Fig. 47. Press in on the arbor lock (C) Fig. 46 to keep the arbor from turning. Use the wrench (D) Fig. 47 to tighten the arbor screw by turning it counter-clockwise.
7. Rotate the cover back to its original position and replace the screw removed in **STEP 1**.

## BRUSH INSPECTION AND REPLACEMENT

Brush life varies, depending on the load on the motor. Check the brushes after the first 50 hours of use for a new machine, or after a new set of brushes has been installed. After the first check, examine them after every 10 hours of use until replacement is necessary. To inspect the brushes:

**⚠ WARNING** DISCONNECT THE MACHINE FROM THE POWER SOURCE.

1. Open the brush holders (A) Fig. 48, located on either side of the motor housing.
2. Remove the brushes (B) Fig. 49.
3. If the carbon on either brush is worn to 3/16" or if either spring or shunt wire is burned or damaged, replace both brushes.
4. If the brushes are serviceable, reinstall them.

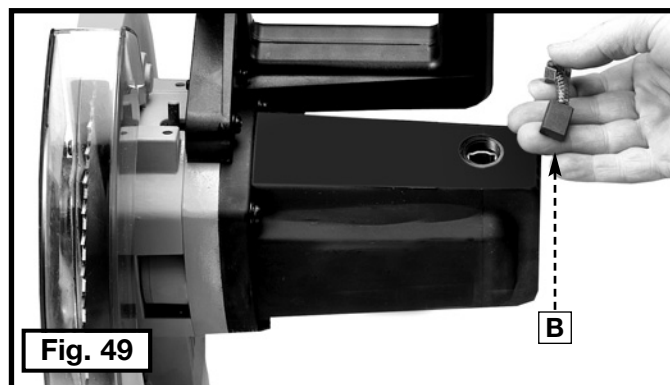
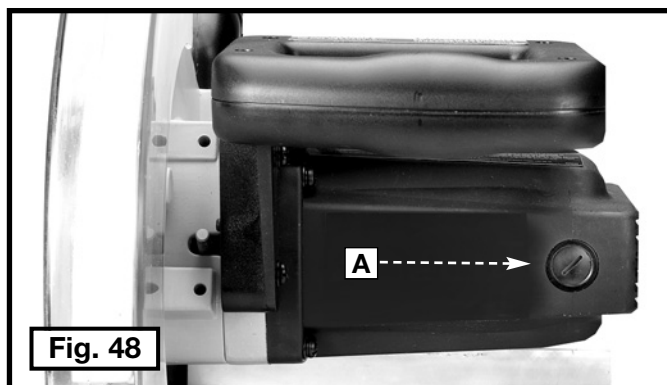

## SERVICE



## PARTS, SERVICE OR WARRANTY ASSISTANCE

All Delta Machines and accessories are manufactured to high quality standards and are serviced by a network of Porter-Cable • Delta Factory Service Centers and Delta Authorized Service Stations. To obtain additional information regarding your Delta quality product or to obtain parts, service, warranty assistance, or the location of the nearest service outlet, please call 1-800-223-7278 (In Canada call 1-800-463-3582).

## ACCESSORIES

A complete line of accessories is available from your Delta Supplier, Porter-Cable • Delta Factory Service Centers, and Delta Authorized Service Stations. Please visit our Web Site [www.deltamachinery.com](http://www.deltamachinery.com) for a catalog or for the name of your nearest supplier.

**⚠ WARNING** Since accessories other than those offered by Delta have not been tested with this product, use of such accessories could be hazardous. For safest operation, only Delta recommended accessories should be used with this product.

## WARRANTY



### Two Year Limited New Product Warranty

Delta will repair or replace, at its expense and at its option, any new Delta machine, machine part, or machine accessory which in normal use has proven to be defective in workmanship or material, provided that the customer returns the product prepaid to a Delta factory service center or authorized service station with proof of purchase of the product within two years and provides Delta with reasonable opportunity to verify the alleged defect by inspection. For all refurbished Delta product, the warranty period is 180 days. Delta may require that electric motors be returned prepaid to a motor manufacturer's authorized station for inspection and repair or replacement. Delta will not be responsible for any asserted defect which has resulted from normal wear, misuse, abuse or repair or alteration made or specifically authorized by anyone other than an authorized Delta service facility or representative. Under no circumstances will Delta be liable for incidental or consequential damages resulting from defective products. This warranty is Delta's sole warranty and sets forth the customer's exclusive remedy, with respect to defective products; all other warranties, express or implied, whether of merchantability, fitness for purpose, or otherwise, are expressly disclaimed by Delta.



## PORTER-CABLE • DELTA SERVICE CENTERS (CENTROS DE SERVICIO DE PORTER-CABLE • DELTA)

Parts and Repair Service for Porter-Cable • Delta Machinery are Available at These Locations  
(Obtenga Refaccion de Partes o Servicio para su Herramienta en los Siguientes Centros de Porter-Cable • Delta)

### ARIZONA

Phoenix 85013-2906  
4501 N. 7th Ave.  
Phone: (602) 279-6414  
Fax: (602) 279-5470

### CALIFORNIA

Ontario 91761 (Los Angeles)  
3949A East Guasti Road  
Phone: (909) 390-5555  
Fax: (909) 390-5554

San Diego 92111  
7290 Clairemont Mesa Blvd.  
Phone: (858) 279-2011  
Fax: (858) 279-0362

San Leandro 94577 (Oakland)  
3039 Teagarden Street  
Phone: (510) 357-9762  
Fax: (510) 357-7939

### COLORADO

Denver 80223  
700 West Mississippi Ave.  
Phone: (303) 922-8325  
Fax: (303) 922-0245

### FLORIDA

Davie 33314 (Miami)  
4343 South State Rd. 7 (441)  
Unit #107  
Phone: (954) 321-6635  
Fax: (954) 321-6638

Tampa 33634  
4909 West Waters Ave.  
Phone: (813) 884-0434  
Fax: (813) 888-5997

### GEORGIA

Forest Park 30297 (Atlanta)  
5442 Frontage Road,  
Suite 112  
Phone: (404) 608-0006  
Fax: (404) 608-1123

### ILLINOIS

Addison 60101 (Chicago)  
400 South Rohlwing Rd.  
Phone: (630) 424-8805  
Fax: (630) 424-8895

### KANSAS

Overland Park 66214  
9201 Quivira Road  
Phone: (913) 495-4330  
Fax: (913) 495-4378

### MARYLAND

Elkridge 21075 (Baltimore)  
7397-102 Washington Blvd.  
Phone: (410) 799-9394  
Fax: (410) 799-9398

### MASSACHUSETTS

Franklin 02038 (Boston)  
Franklin Industrial Park  
101E Constitution Blvd.  
Phone: (508) 520-8802  
Fax: (508) 528-8089

### MICHIGAN

Madison Heights 48071 (Detroit)  
30475 Stephenson Highway  
Phone: (248) 597-5000  
Fax: (248) 597-5004

### MINNESOTA

Eden Prairie 55344  
9709 Valley View Road  
Phone: (952) 884-9191  
Fax: (952) 884-3750

### MISSOURI

St. Louis 63146  
11477 Page Service Drive  
Phone: (314) 997-9100  
Fax: (314) 997-9183

### NEW YORK

Flushing 11365-1595 (N.Y.C.)  
175-25 Horace Harding Expwy.  
Phone: (718) 225-2040  
Fax: (718) 423-9619

### NORTH CAROLINA

Charlotte 28270  
9129 Monroe Road, Suite 115  
Phone: (704) 841-1176  
Fax: (704) 708-4625

### OHIO

Columbus 43229  
1948 Schrock Road  
Phone: (614) 895-3112  
Fax: (614) 895-3187

Parma Heights OH 44130  
6485 Pearl Road  
Phone: (440) 842-9100  
Fax: (440) 884-3430

### OREGON

Portland 97230  
14811 North East Airport Way  
Phone: (503) 255-6556  
Fax: (503) 255-6543

### PENNSYLVANIA

Willow Grove 19090  
(Philadelphia)  
520 North York Road  
Phone: (215) 658-1430  
Fax: (215) 658-1433

### TEXAS

Carrollton 75006 (Dallas)  
1300 Interstate 35 N, Suite 112  
Phone: (972) 446-2996  
Fax: (972) 446-8157

Houston 77022-2122  
536 East Tidwell Rd.  
Phone: (713) 692-7111  
Fax: (713) 692-1107

### WASHINGTON

Auburn 98001(Seattle)  
3320 West Valley HWY, North  
Building D, Suite 111  
Phone: (253) 333-8353  
Fax: (253) 333-9613

Authorized Service Stations are located in many large cities. Telephone **800-438-2486** or **731-541-6042** for assistance locating one. Parts and accessories for Porter-Cable-Delta products should be obtained by contacting any Porter-Cable-Delta Distributor, Authorized Service Center, or Porter-Cable-Delta Factory Service Center. If you do not have access to any of these, call **800-223-7278** and you will be directed to the nearest Porter-Cable-Delta Factory Service Center. Las Estaciones de Servicio Autorizadas están ubicadas en muchas grandes ciudades. Llame al **800-438-2486** ó al **731-541-6042** para obtener asistencia a fin de localizar una. Las piezas y los accesorios para los productos Porter-Cable-Delta deben obtenerse poniéndose en contacto con cualquier distribuidor Porter-Cable-Delta, Centro de Servicio Autorizado o Centro de Servicio de Fábrica Porter-Cable-Delta. Si no tiene acceso a ninguna de estas opciones, llame al **800-223-7278** y le dirigirán al Centro de Servicio de Fábrica Porter-Cable-Delta más cercano.

## CANADIAN PORTER-CABLE • DELTA SERVICE CENTERS

### ALBERTA

Bay 6, 2520-23rd St. N.E.  
Calgary, Alberta  
T2E 8L2  
Phone: (403) 735-6166  
Fax: (403) 735-6144

### BRITISH COLUMBIA

8520 Baxter Place  
Burnaby, B.C.  
V5A 4T8  
Phone: (604) 420-0102  
Fax: (604) 420-3522

### MANITOBA

1699 Dublin Avenue  
Winnipeg, Manitoba  
R3H 0H2  
Phone: (204) 633-9259  
Fax: (204) 632-1976

### ONTARIO

505 Southgate Drive  
Guelph, Ontario  
N1H 6M7  
Phone: (519) 767-4132  
Fax: (519) 767-4131

### QUÉBEC

1515 ave.  
St-Jean Baptiste, Suite 160  
Québec, Québec  
G2E 5E2  
Phone: (418) 877-7112  
Fax: (418) 877-7123

1447, Begin  
St-Laurent, (Montréal),  
Québec  
H4R 1V8  
Phone: (514) 336-8772  
Fax: (514) 336-3505

The following are trademarks of PORTER-CABLE • DELTA (Las siguientes son marcas registradas de PORTER-CABLE • DELTA S.A.) (Les marques suivantes sont des marques de fabrication de la PORTER-CABLE • DELTA): Auto-Set®, BAMMER®, B.O.S.S.®, Builder's Saw®, Contractor's Saw®, Contractor's Saw II™, Delta®, DELTACRAFT®, DELTAGRAM™, Delta Series 2000™, DURATRAC™, Emc2™, FLEX®, Flying Chips™, FRAME SAW®, Grip Vac™, Homcraft®, INNOVATION THAT WORKS®, Jet-Lock®, JETSTREAM®, 'kickstand®, LASERLOC®, MICRO-SET®, Micro-Set®, MIDI LATHE®, MORTEN™, NETWORK™, OMNIJIG®, POCKET CUTTER®, PORTA-BAND®, PORTA-PLANE®, PORTER-CABLE®&(design), PORTER-CABLE®PROFESSIONAL POWER TOOLS, PORTER-CABLE REDEFINING PERFORMANCE™, Posi-Matic®, Q-3®&(design), QUICKSAND®&(design), QUICKSET™, QUICKSET II®, QUICKSET PLUS™, RIPTIDE™&(design), SAFE GUARD II®, SAFE-LOC®, Sanding Center®, SANDTRAP®&(design), SAW BOSS®, Sawbuck™, Sidekick®, SPEED-BLOC®, SPEEDMATIC®, SPEEDTRONIC®, STAIR EASE®, The American Woodshop®&(design), The Lumber Company®&(design), THE PROFESSIONAL EDGE®, THE PROFESSIONAL SELECT®, THIN-LINE™, TIGER®, TIGER CUB®, TIGER SAW®, TORQBUSTER®, TORQ-BUSTER®, TRU-MATCH™, TWIN-LITE®, UNIGUARD®, Unifence®, UNIFEEDER™, Unihead®, Uniplane™, Unirip®, Unisaw®, Univise®, Versa-Feeder®, VERSA-PLANE®, WHISPER SERIES®, WOODWORKER'S CHOICE™.

Trademarks noted with ™ and ® are registered in the United States Patent and Trademark Office and may also be registered in other countries. Las Marcas Registradas con el signo de ™ y ® son registradas por la Oficina de Registros y Patentes de los Estados Unidos y también pueden estar registradas en otros países.

PC7.2-0105-149

## Free Manuals Download Website

<http://myh66.com>

<http://usermanuals.us>

<http://www.somanuals.com>

<http://www.4manuals.cc>

<http://www.manual-lib.com>

<http://www.404manual.com>

<http://www.luxmanual.com>

<http://aubethermostatmanual.com>

Golf course search by state

<http://golfingnear.com>

Email search by domain

<http://emailbydomain.com>

Auto manuals search

<http://auto.somanuals.com>

TV manuals search

<http://tv.somanuals.com>