

# FURUNO

# OPERATOR'S MANUAL

AUTOPILOT

---

MODEL NAVpilot-500

---

**NAV***pilot*



**FURUNO ELECTRIC CO., LTD.**  
NISHINOMIYA, JAPAN



# SAFETY INSTRUCTIONS



## WARNING



**ELECTRICAL  
SHOCK  
HAZARD**

**Do not open the equipment unless you are well familiar with electrical circuits.**

Only qualified personnel should work inside the equipment.

**Do not set the course changing speed too high.**

The boat will be turned too sharply at the course change, which could create a very dangerous situation.

**Do not use the autopilot in the following situation:**

- Harbor entrance or narrow channel
- Where vessels change course often, such as a cape or small island

**Observe the following cautions when using the autopilot:**

- Maintain a vigilant watch
- Watch for drifting of vessel

**In an emergency, manually steer the vessel.**

The autopilot cannot avoid vessels, etc. automatically.

**Do not use the SIMULATION mode on the boat.**

The rudder may move. This is special-purpose mode for technicians.



## WARNING

**Do not use the ORBIT mode in rough sea.**

Because the boat turns a 360-degree circle around the waypoint a large wave or strong wind can cause the boat to capsize.

**Confirm that no objection is in the general vicinity of the waypoint.**

The distance from the waypoint to the turning point depends on boat's speed.

**Do not use the SIMULATION mode on the boat.**

The rudder may move. This is special-purpose mode for technicians.



## CAUTION

**In case of power failure turn off the autopilot or manually steer the vessel.**

Leaving the equipment in the AUTO or NAV mode during power failure will cause wear on the rudder mechanism.

**Use the correct fuse.**

Use of a wrong fuse can cause fire or damage the equipment.

### WARNING LABEL

**A warning label is attached to the processor unit. Do not remove the label. If the label is missing or damaged, contact your dealer about replacement.**

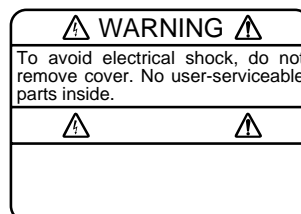

Name: Warning Label (1)  
Type: 86-003-1011  
Code No.: 100-236-231

# TABLE OF CONTENTS

---

<b>FORWORD .....</b>	<b>iv</b>
<b>SYSTEM CONFIGURATION .....</b>	<b>v</b>
<b>1. PRINCIPLE OF THE AUTOPILOT .....</b>	<b>1-1</b>
Principle of Autopilot .....	1-1
Principle of Operation .....	1-2
<b>2. BASIC OPERATION .....</b>	<b>2-1</b>
2.1 Operating Controls .....	2-1
2.2 Turning On/Off .....	2-2
2.3 Adjusting Brilliance and Contrast .....	2-3
2.4 Displays .....	2-3
2.4.1 Selecting the data shown on Normal and Data Displays .....	2-4
2.4.2 Selecting the display on Graphic Display .....	2-7
2.4.3 Selecting data for analog indicator .....	2-8
<b>3. STEERING MODES .....</b>	<b>3-1</b>
3.1 STBY Mode .....	3-1
3.2 AUTO Mode .....	3-2
3.2.1 Using the AUTO mode .....	3-2
3.2.2 ADVANCED AUTO mode .....	3-3
3.2.3 TURN mode (For AUTO mode) .....	3-4
3.3 NAV Mode .....	3-5
3.3.1 Starting the NAV mode .....	3-5
3.3.2 Selecting sailing method of NAV mode .....	3-6
3.3.3 Switching waypoint .....	3-7
3.3.4 Selecting boat's movement at the destination (or last) waypoint .....	3-7
3.3.5 Navigating to TLL point (FISHING mode) .....	3-10
3.4 REMOTE Mode .....	3-11
3.5 DODGE Mode .....	3-17
3.5.1 Dodging in STBY mode .....	3-17
3.5.2 Dodging in AUTO or NAV mode .....	3-18
<b>4. MENU OPERATION .....</b>	<b>4-1</b>
4.1 STBY Mode Menu .....	4-1
4.1.1 Offsetting data .....	4-1
4.1.2 Setting parameters .....	4-3
4.1.3 Setting the units of measurements .....	4-10
4.1.4 Setting other menu items .....	4-12

<b>5. ALARMS</b> .....	<b>5-1</b>
5.1 ALARM Menu .....	5-1
5.1.1 Selecting the alarm buzzer .....	5-2
5.1.2 Selecting the beep pattern.....	5-2
5.1.3 Setting the watch alarm.....	5-3
5.1.4 Setting the heading deviation alarm .....	5-3
5.1.5 Setting the cross-track error limit.....	5-3
5.1.6 Setting the speed alarm .....	5-4
5.1.7 Setting the depth alarm .....	5-5
5.1.8 Setting the temperature alarm .....	5-6
5.1.9 Setting the trip distance alarm .....	5-6
5.1.10 Clearing the trip distance.....	5-7
5.2 Alarm Information.....	5-7
<b>6. MAINTENANCE &amp; TROUBLESHOOTING</b> .....	<b>6-1</b>
6.1 Preventive Maintenance.....	6-1
6.2 Replacement of Fuse .....	6-2
6.3 Diagnostics .....	6-2
6.4 Clearing Memories.....	6-6
6.5 Error Messages.....	6-7
<b>MENU TREE</b> .....	<b>MN-1</b>
<b>SPECIFICATIONS</b>	

# FOREWORD

---

## A Word to the Owner of the NAVpilot-500

Congratulations on your choice of the FURUNO NAVpilot-500 AUTOPILOT.

For over 50 years FURUNO Electric Company has enjoyed an enviable reputation for innovative and dependable marine electronics equipment. This dedication to excellence is furthered by our extensive global network of agents and dealers.

Your autopilot is designed and constructed to meet the rigorous demands of the marine environment. However, no machine can perform its intended function unless installed, operated and maintained properly. Please carefully read and follow the recommended procedures for operation and maintenance.

We would appreciate hearing from you, the end-user, about whether we are achieving our purposes.

Thank you for considering and purchasing FURUNO equipment.

## Features

- Self learning program to continuously improve the steering parameters for safe and expeditious navigation
- Two steering modes – AUTO (Heading Control System) and NAV (Track Control System)
- Dodging from the control unit or remote controller
- Available for solenoid drive and reversible hydraulic
- Max. six control units may be connected (using two ports of the processor unit)
- Menu operation for simplified control
- Display modes: Autopilot/Track control modes with rudder angle, L/L, Highway, Two customized displays, compass rose

# SYSTEM CONFIGURATION

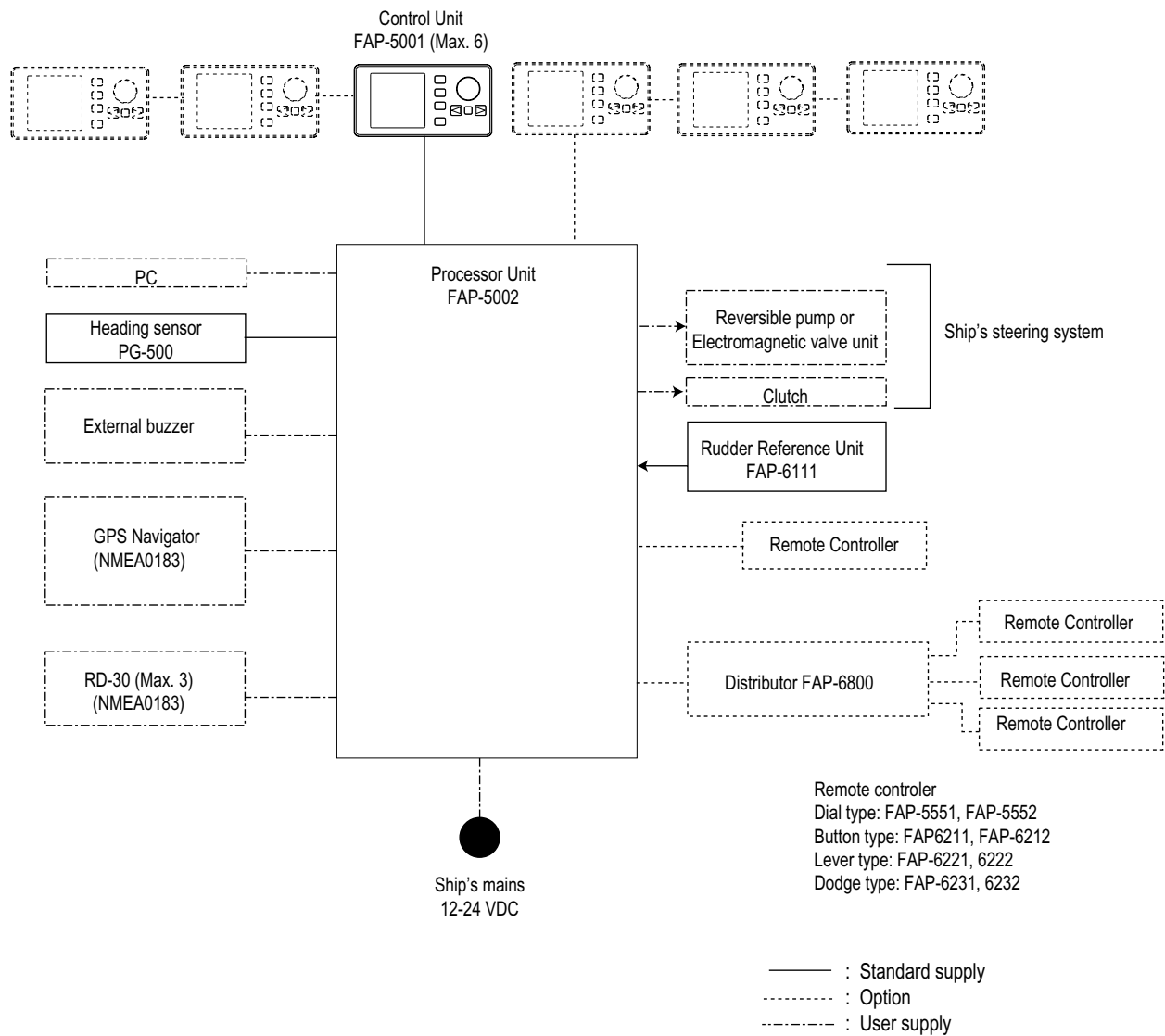

System configuration of NAVpilot-500

This page is intentionally left blank.

# 1. PRINCIPLE OF THE AUTOPILOT

---

## Principle of Autopilot

Autopilot is an automatic device for steering a vessel maintaining its heading in an intended direction. Anyone can appreciate the advantages of the autopilot – being free to carry out navigational checks, trim adjustments or simply to relax and enjoy.

The autopilot utilizes a proportional rate system to steer the boat. The proportional rate system is similar to the highly accurate and reliable system used on aircraft, missiles and space vehicles. The proportional rate autopilot provides the necessary course correction to the steering gears in proportion to the speed and amount the boat moves off course.

With the removal of the dead band, the autopilot no longer wanders within a dead band but now steers a prescribed course, taking action within the presence of even a minute course error. The amount of action depends on the course error detected; that is, when the course error rate is small a very low helm correction rate is applied.

Because the wandering is eliminated, the proportional rate autopilot has the advantages of low power consumption and low wear and tear on the autopilot and the steering system. Off-course correction is smooth, not jerking back and forth at full speed.



## Principle of Operation

In the AUTO modes, the heading information from an associated sensor is continuously compared with the set course (in the NAV mode, the course to the waypoint set on the plotter connected). With the boat on course, the two signals are equal.

If the boat goes off course, the difference between the primary heading and the set course will change proportionally and there will be an imbalance at the comparator, whose output will move up or down depending on whether the course error is to the left or right of the set course.

The rudder continues to move until a balanced condition is obtained at the comparator, at which point the drive switches off.

To set the rudder when the boat is off-course, the rudder signal is generated at the rudder reference unit, then delivered the processor unit.

## 2. BASIC OPERATION

### 2.1 Operating Controls

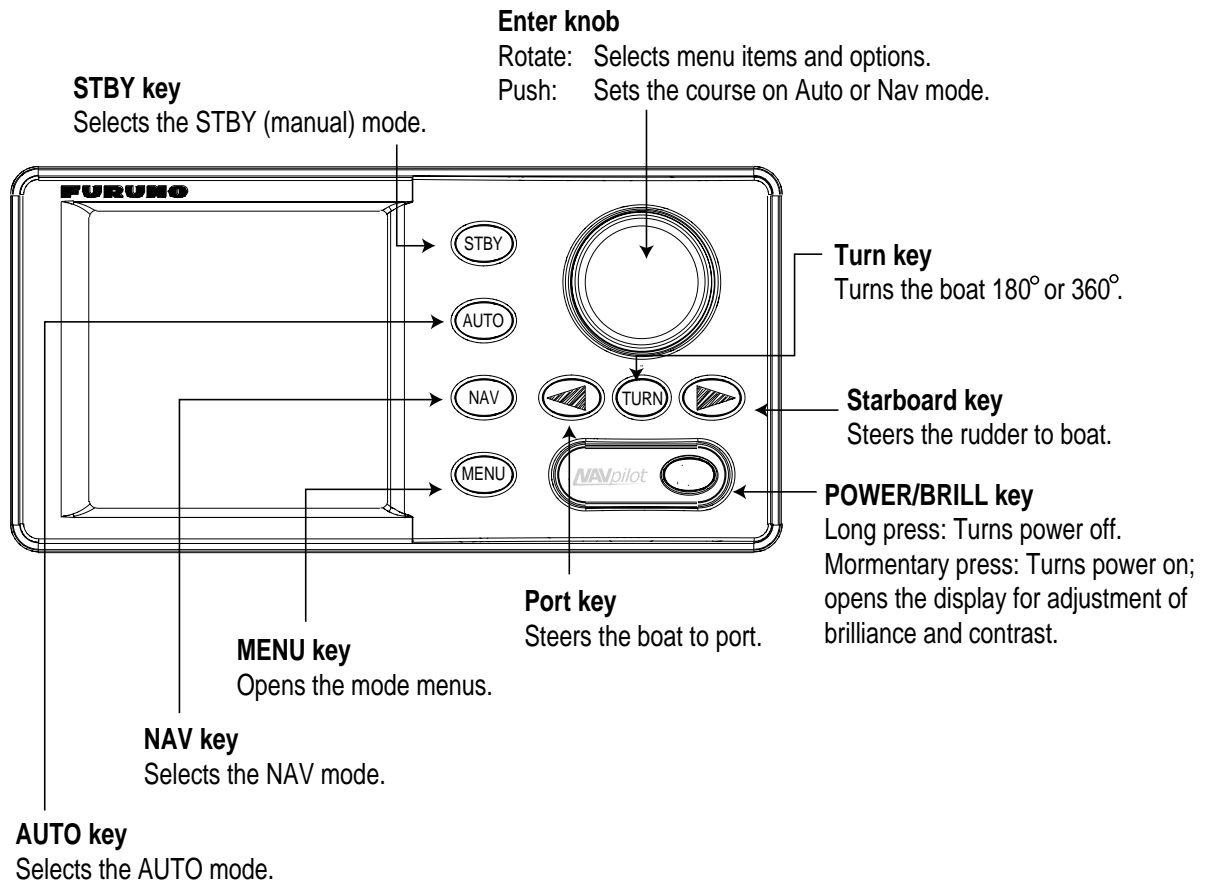

*Control unit, front view*

## 2.2 Turning On/Off

Press the [POWER/BRILL] key to turn the unit on before leaving the port, because several minutes are necessary to allow for stabilization of the heading data from the heading sensor. (For PG-500, see Note 2 shown below.) A beep sounds and the equipment proceeds in the sequence shown below, displaying product information and startup test results. The startup test checks the ROM, RAM, backed up data and communication between the control unit and processor unit for proper operation. Also it checks the inputs of heading signal and rudder angle signal for the processor unit. If NG appears an appropriate message appears on the screen. For any NG, try to press any key to go to the next screen. However, the equipment may not work properly. Contact your dealer for advice.

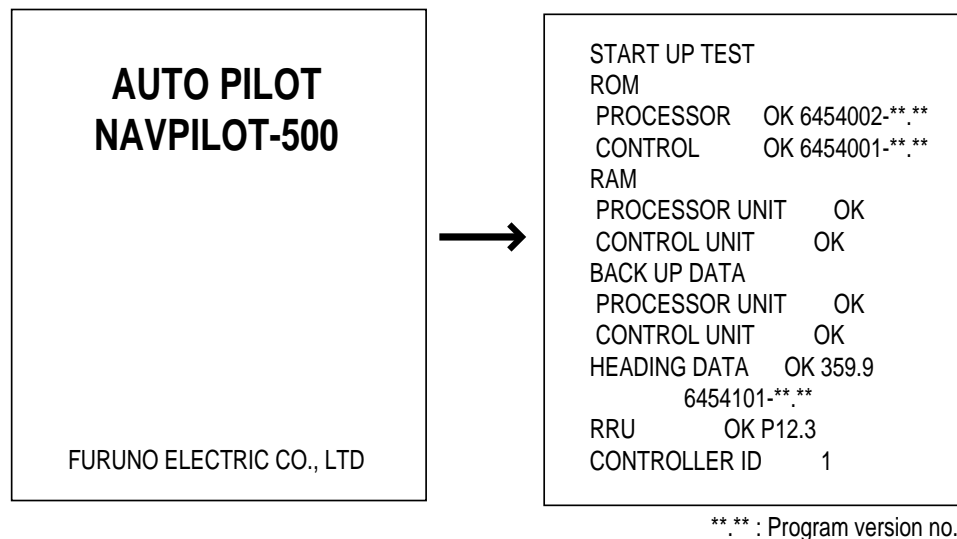

### *Startup sequence*

After the startup test is completed, "STBY" appears on the screen. This means the equipment may now be operated manually.

**Note 1:** The first time you turn on the power, you are asked if you want to start the simulation mode, which provides simulated operation of the equipment. Push the [ENTER] knob to start the simulation mode, or any key to escape. If you pressed a key except the [ENTER] knob, you are asked if you want to set the installation menu. Press the [ENTER] knob to go to the installation menu, or any key to go to STBY. For details about the installation menu, contact your dealer.

**Note 2:** When the Integrated Heading Sensor PG-500 is connected, press the [POWER/BRILL] key four minutes before leaving the port to use the AUTO mode which needs stabilized bearing data.

### **Turning the power off**

Press and hold down the [POWER/BRILL] key until the screen goes blank. The time remaining until the power is turned off is shown on the screen.

## 2.3 Adjusting Brilliance and Contrast

The brilliance and contrast can be adjusted as below:

1. Momentarily press the [POWER/BRILL] key. The CONTRAST and BRILL window appears.

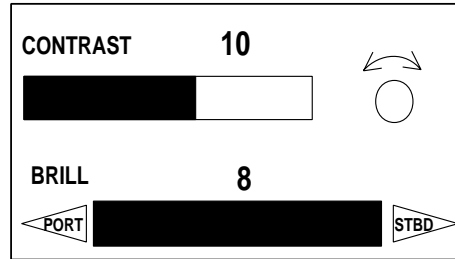

*Contrast, brilliance window*

2. Rotate the [ENTER] knob to adjust display contrast; clockwise to raise the contrast and counter-clockwise to lower it. (16 levels are available.)  
The contrast can also be adjusted by pressing the [POWER/BRILL] key.
3. Press the [PORT] or [STBD] key to adjust display brilliance, [PORT] to lower the brilliance and [STBD] to raise it. (Eight levels are available.)

To close the CONTRAST and BRILL window, press any key except the [POWER/BRILL], [STBD] or [PORT] key.

## 2.4 Displays

There are four types of displays: Normal display 1, Normal display 2, Graphic display and Data display.

To choose a display mode, press a mode key (AUTO, NAV, STBY). Each time a mode key is pressed the display changes in the sequence shown below.

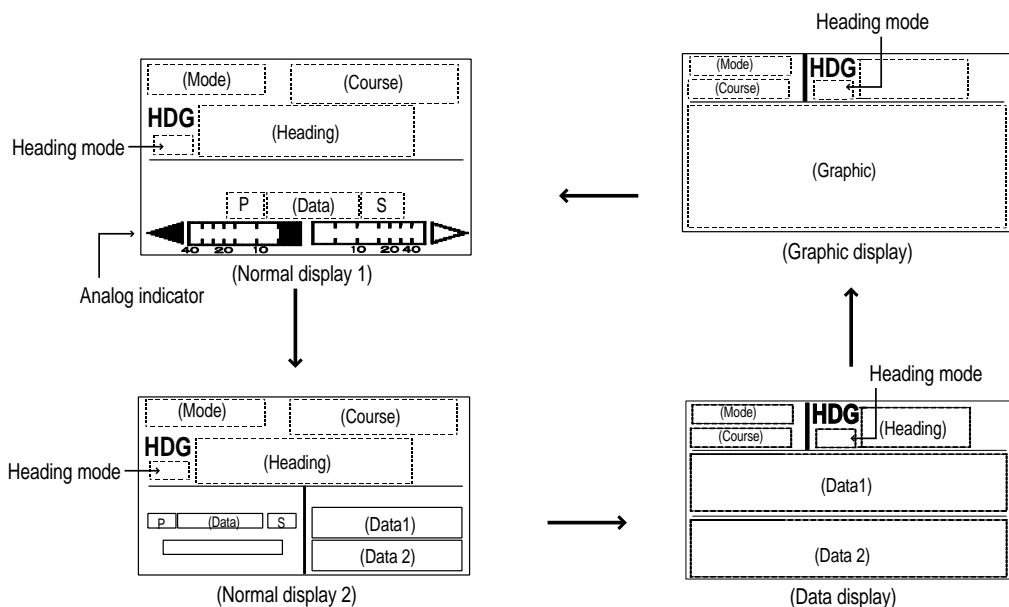

*Displays*

### 2.4.1 Selecting the data shown on Normal and Data Displays

Some display modes may be set up to suit your operating needs, on the SCREEN SETUP menu.

#### Selecting data for Normal Display 2 screen

You can select the data to show on the upper and lower half of the Normal Display 2.

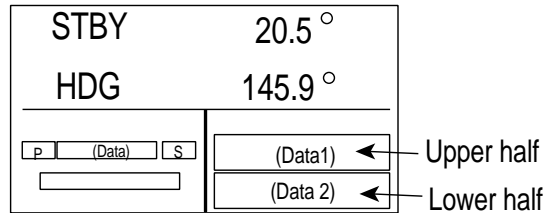

*Normal Display 2*

1. Press the [STBY] and [MENU] key in order to show the STBY menu.
2. Rotate the [ENTER] knob to select the SCREEN SETUP, and then press the [ENTER] knob to show the SCREEN SETUP menu.

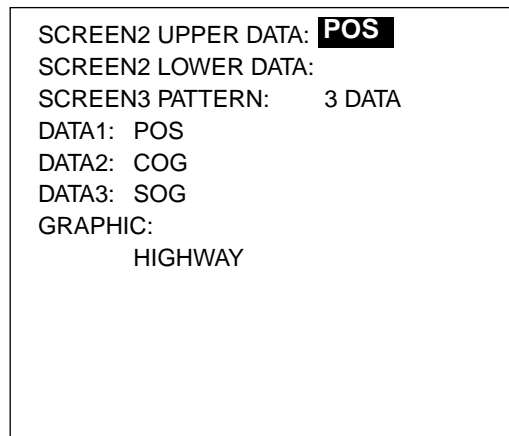

*Screen setup menu*

3. Rotate the [ENTER] knob to select “SCREEN 2 DATA UPPER” or “SCREEN 3 DATA LOWER” from the SCREEN SETUP menu.
4. Press the [ENTER] knob to show the options window.
5. Rotate the [ENTER] knob to select the data which you want to show on the upper or lower half of the Normal Display 2.

Data available for display in SCREEN 2 UPPER and LOWER

Menu option	Displayed data
POS	Own ship's position (L/L)
COG	Course over ground
SOG	Speed over ground
STW	Speed through water
TMP	Water temperature
DPT	Depth
BRG	Bearing to waypoint
RNG	Range to waypoint
WPT POS	Waypoint position (L/L)
XTE	Cross-track error
TTG	Time-to-Go to Destination
ETA	Estimated Time of Arrival
DATE	Date
TIME	Time
WIND T*	Wind direction and speed (True)
WIND R**	Wind direction and speed (Relative)
VOLT	Input/output power voltage to the processor unit
TRIP	Trip distance

\*True: The speed and direction (in relation to ship's bow) of the wind felt or measured when stationary.

\*\*Relative: The direction (in relation to ship's bow) and speed of the wind as it appears to those on board, relative to the speed and direction of the boat; combination of the true wind and the wind caused by the boat's movement.

6. Press the [ENTER] knob.

7. Press the [MENU] key to close the menu.

**Selecting the display layout for Data Display**

You can show two or three data on the Data Display.

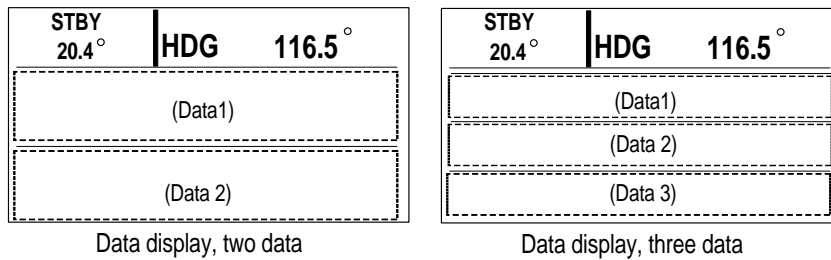

*Data Displays*

1. Open the SCREEN SETUP menu referring to page 2-4.
2. Rotate the [ENTER] knob to select “SCREEN 3 PATTERN”.
3. Press the [ENTER] knob to show the screen 3 options window.



*Screen 3 pattern options window*

4. Rotate the [ENTER] knob to select 2 DATA or 3 DATA as appropriate.
5. Press the [ENTER] knob.
6. Press the [ENTER] knob to close the menu.

**Selecting data for Data Display**

You may choose which data to show on the Data Display. Data 3 is available only when you select 3DATA at “SCREEN 3 PATTERN” shown above.

1. Open the SCREEN SETUP menu referring to the page 2-5.
2. Rotate the [ENTER] knob to select “DATA 1”, “DATA 2” or “DATA 3”.
3. Press the [ENTER] knob show the option window.  
The contents are same as the table shown on the previous page.
4. Rotate the [ENTER] knob to select data.
5. Press the [ENTER] knob.
6. Press the [MENU] key to close the menu.

### 2.4.2 Selecting the display on Graphic Display

COMPASS, RUDDER ANGLE, HIGHWAY, WIND TRUE INDICATOR, WIND RELATIVE INDICATOR, DEPTH GRAPH or TEMP GRAPH can be shown on the Graphic Display. Note that the appropriate sensors are necessary to display data.

1. Open the SCREEN SETUP menu referring to page 2-4.
2. Rotate the [ENTER] knob to select "GRAPHIC".
3. Press the [ENTER] knob to show the graphic options window.

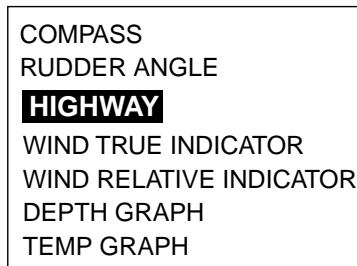

*Graphic options window*

4. Rotate the [ENTER] knob to select the graphic type.

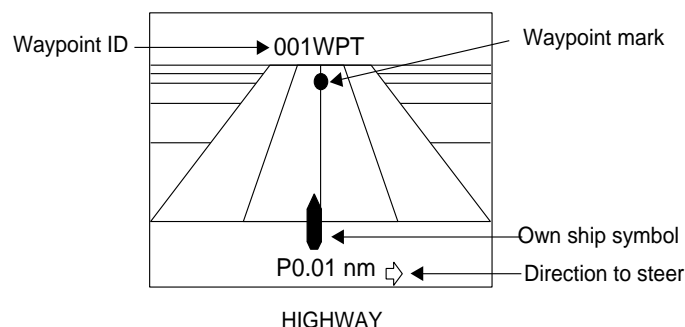
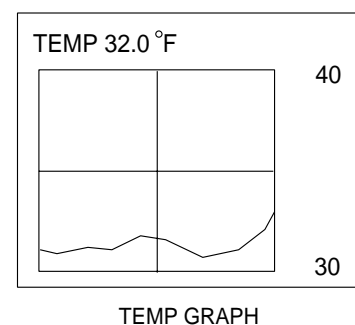
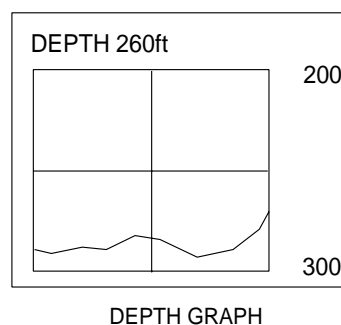
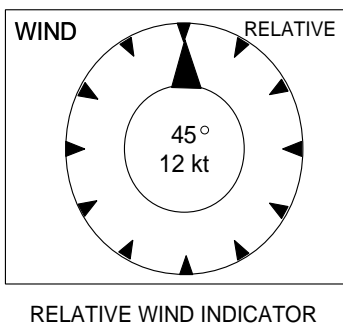
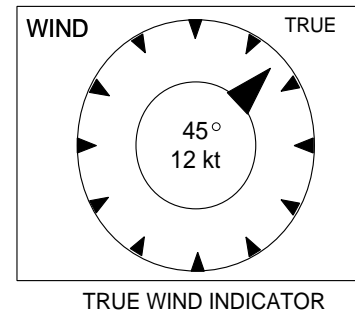
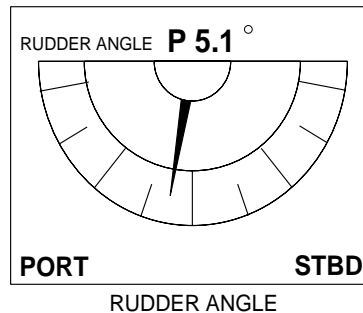
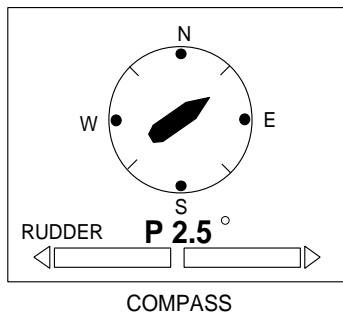

*Graphic displays*

5. Press the [ENTER] knob and [MENU] key in order to close the menu.



### 2.4.3 Selecting data for analog indicator

Choose what to display on the analog indicator display on Normal Display 1 and 2.

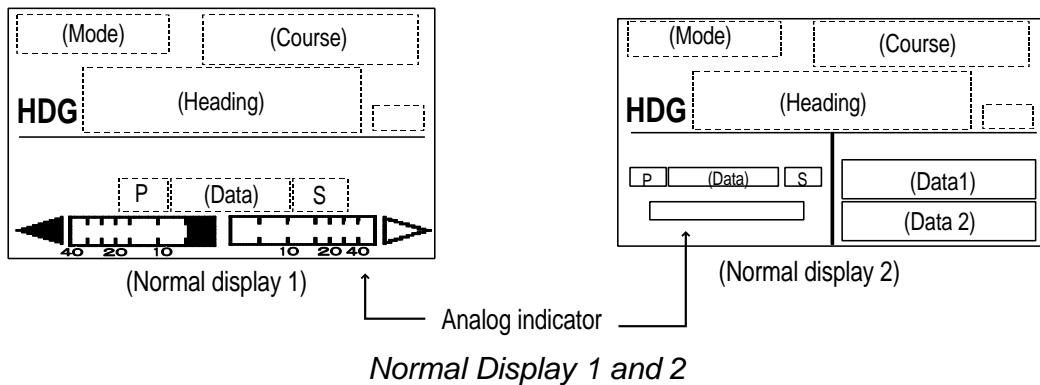

1. Press the [STBY] and [MENU] key in order to show the STBY menu.
2. Rotate the [ENTER] knob to select "DISPLAY SETUP".
3. Press the [ENTER] knob to show the DISPLAY SETUP menu.

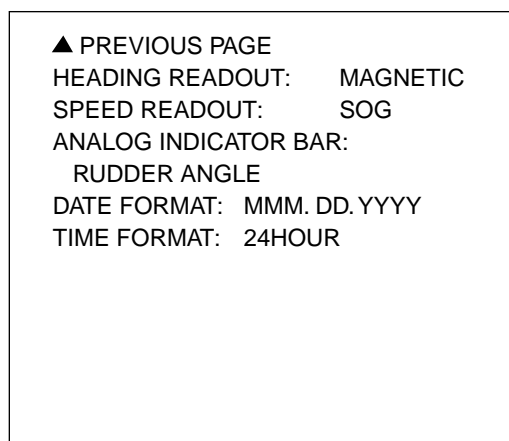
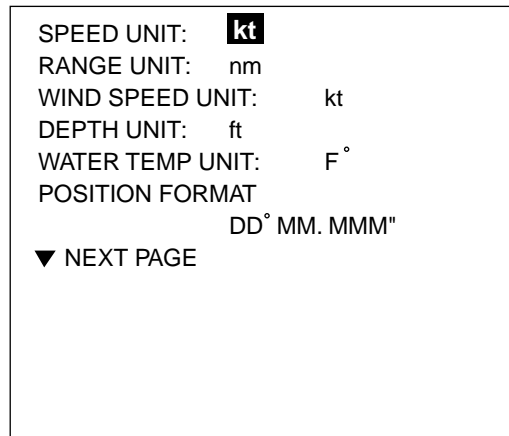

#### *Display setup menu*

To change pages, select "▼NEXT PAGE" or "▲PREVIOUS PAGE" and press the [ENTER] knob.

4. Rotate the [ENTER] knob to select “ANALOG INDIACATOR BAR” on the second page.
5. Press the [ENTER] knob to show the bar indicator options window.

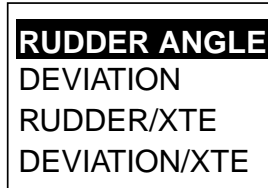

*Analog indicator bar options window*

6. Rotate the [ENTER] knob to select option you desired to show.  
Note the following.  
RUDDER/XTE: Rudder in STBY and AUTO mode, XTE in NAV mode.  
DEVIATION/XTE: Deviation in STBY and AUTO mode, XTE in NAV mode.
7. Press the [ENTER] knob.
8. Press the [MENU] key to close the menu.

## 2. BASIC OPERATION

This page is intentionally left blank.

# 3. STEERING MODES

The NAVpilot-500 system is capable of five primary steering modes: STBY (manual), AUTO, NAV, REMOTE (FU and NFU) and DODGE.

In case of emergency, for example, collision avoidance, turn the helm quickly to control the boat manually. The alarm sounds and "STBY" flashes on the display. To return to the normal mode, press the [STBY], [AUTO] or [NAV] mode.

## 3.1 STBY Mode

After turning on the power, the equipment goes to the STBY mode.

This is a manual steering mode. When sailing out of a harbor, steer the vessel in the STBY mode.

Press the [STBY] key.

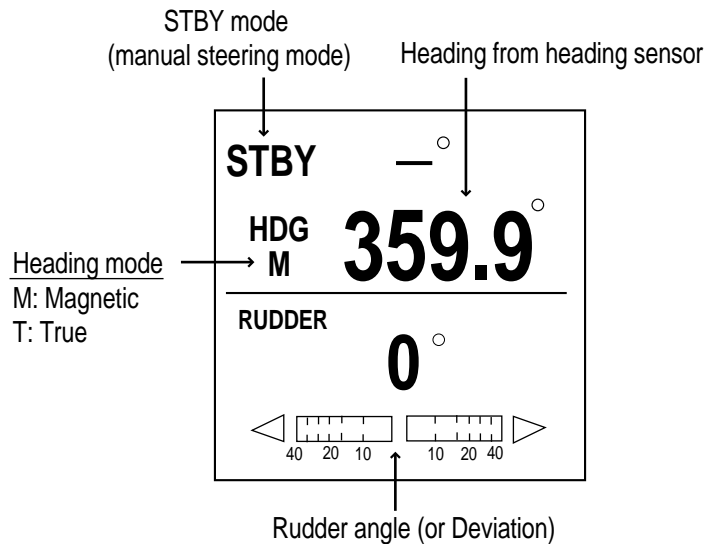

*STBY mode display*

## 3.2 AUTO Mode

### 3.2.1 Using the AUTO mode

The AUTO mode makes the NAVpilot-500 steer the boat automatically on a set course.

Note: The AUTO mode will not bring your boat to the destination when wind or tide prevails. Use this mode for a short straight voyage. Otherwise switch to the NAV mode shown on page 3-5.

1. Direct the boat to the intended course desired.  
The course in this mode is a line connecting between the origin and the destination.
2. Press the [AUTO] key to access the Auto mode.  
Your boat will automatically be steered toward the course at the moment the [AUTO] key is pressed.  
Whenever the heading deviates from the set course, the NAVpilot-500 automatically adjusts the rudder to return the boat to the set course.
3. To change or readjust the course setting in the AUTO mode, simply rotate the [ENTER] knob to set the desired course.
4. Press the [STBY] key to leave AUTO steering in an emergency. You can steer your boat by the helm.

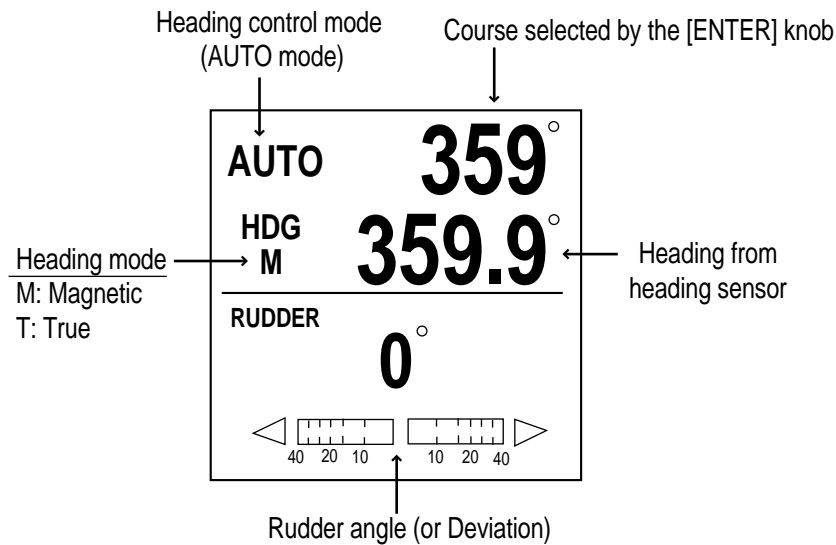

*AUTO mode display*

### 3.2.2 ADVANCED AUTO mode

AUTO mode maintains set course but the track may be shifted by current or wind. ADVANCED AUTO mode maintains set course without deviating from the track. This mode can be enabled by connecting a navaid which can output own ship's position data (L/L) in NMEA0183 format to the NAVpilot-500.

After connecting to a navaid which outputs position data, press the [AUTO] key. The NAVpilot-500 calculates the course based on the present position and heading. In this mode, "AUTO" appears on the display.

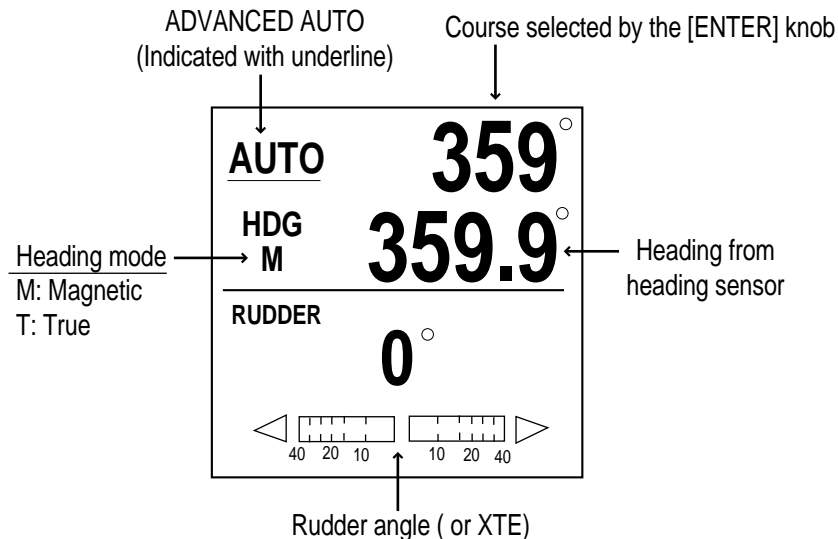

*ADVANCED AUTO mode display*

#### Enabling the ADVANCED AUTO mode

You can select whether to use the ADVANCED AUTO mode or not as follows.

1. In the AUTO mode, press the [MENU] key to show the AUTO mode menu.
2. Rotate the [ENTER] knob to select "ADVANCED AUTO", and then press the [ENTER] knob to show the advanced auto options window.

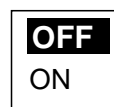

*Advanced auto options window*

3. Rotate the [ENTER] knob to select "ON".  
When you want to finish the ADVANCED AUTO mode, select "OFF".
4. Press the [ENTER] knob, [MENU] key in order close the menu.

### 3.2.3 TURN mode (For AUTO mode)

The [TURN] key provides a turn feature when in the AUTO mode.

This function changes the current set course to be 180° or 360°.

This is useful when you want to back to the position where a fish school appears on the echo sounder.

#### **180° turn**

180° turn changes the current set course 180° in the opposite direction (↻).

1. In the AUTO mode, press the [TURN] key to show the setting window.

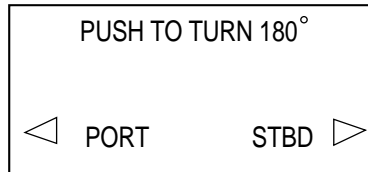

*180° turn setting window*

2. Press the [PORT] or [STBD] key depending on the direction you want to turn. The alarm sounds to notify you that the boat is turning. The indication "180T" replaces "AUTO (or AUTO)" on the display.
3. When the message "TURN COMPLETED" appears after the boat has turned 180°, press the [ENTER] knob to silence the alarm. Control is returned to AUTO mode automatically, and the indication "180T" is replaced with "AUTO (or AUTO)."

#### **360° turn**

360° turn provides a continuous turn feature with a constant rate of turn in a circle (↻).

1. In the AUTO mode, press the [TURN] key to show the setting window twice.

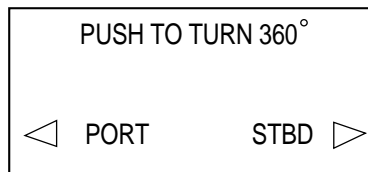

*360° turn setting window*

2. Press the [PORT] or [STBD] key depending on the direction you want to turn. The alarm sounds to notify you that the boat is turning. The indication "360T" replaces "AUTO (AUTO)" on the display.
3. When the message "TURN COMPLETED" appears after the boat has turned 360°, press the [ENTER] knob to silence the alarm. Control is returned to AUTO mode automatically, and the indication "360T" is replaced with "AUTO (or AUTO)."

## 3.3 NAV Mode

### 3.3.1 Starting the NAV mode

The plotter connected to the autopilot knows the present position and location to a destination waypoint. The NAVpilot-500, while receiving this information, adjusts the course direction automatically and guides the boat to the destination waypoint as determined by the associated plotter.

1. Set the destination waypoint (or route) on the plotter.
2. Direct the boat's heading to the waypoint.
3. Press the [NAV] key.

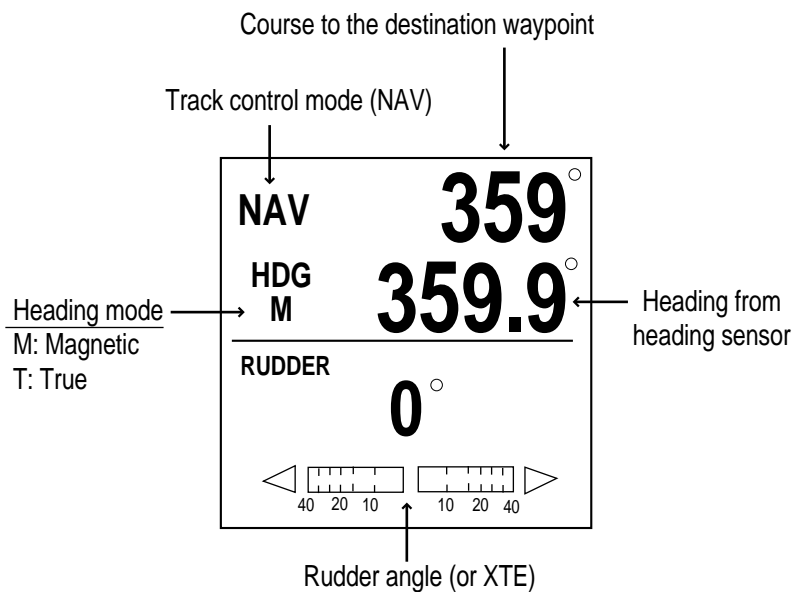

#### *NAV mode display*

The course is automatically set so that the boat sails on the intended course line. When the [NAV] key is pressed, the course changes automatically in order to follow the intended course line. The course reading on the NAVpilot-500 is not always equal to the waypoint direction which is presented on the plotter.

When you intend to navigate following a route, the boat goes to the second waypoint in the route. Select the nearest or desired waypoint before going into the NAV mode.

4. Press the [STBY] or [AUTO] key to terminate the NAV mode.



### 3.3.2 Selecting sailing method of NAV mode

The NAV mode has two sailing methods, COURSE and XTE. When the ship goes out from the course between starting point (previous waypoint for route) and destination waypoint because of tide, wind etc, each method functions as below.

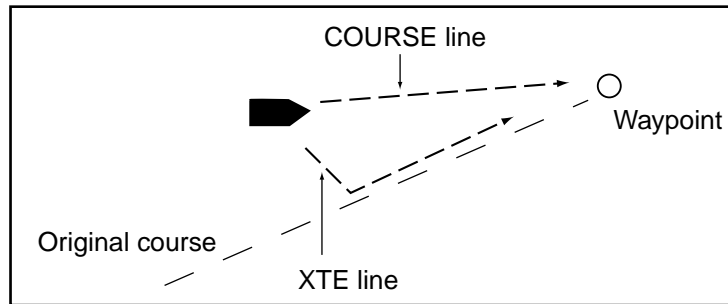

*NAV mode, COURSE and XTE*

A sailing method can be selected from the menu.

1. In the NAV mode, press the [MENU] key to show the NAV mode menu.
2. Rotate the [ENTER] knob to select “NAV MODE”, and then press the [ENTER] knob to show the nav mode options window.



*Nav mode options window*

3. Rotate the [ENTER] knob to select XTE or COURSE as appropriate.  
**XTE:** The boat sails along the course between the starting point and waypoint.  
**COURSE:** The boat goes directly to the waypoint when the boat is off course.
4. Press the [ENTER] knob, [MENU] key in order to close the menu.

### 3.3.3 Switching waypoint

When you arrive at a waypoint on a route in the NAV mode, you can switch to the next waypoint automatically or manually. AUTO switches the TO waypoint when your boat is within the arrival alarm area (set on the plotter). MANUAL requires operator confirmation before switching the TO waypoint, when the boat arrives at a waypoint, notified by sounding the buzzer.

1. In the NAV mode, press the [ENTER] knob to show the NAV mode menu.
2. Rotate the [ENTER] knob to select "WAYPOINT SWITCHING".
3. Press the [ENTER] knob to show the waypoint switching window.



*Waypoint switching options window*

3. Rotate the [ENTER] knob to select AUTO or MANUAL as appropriate.
4. Press the [ENTER] knob, [MENU] key in order to close the menu.

### 3.3.4 Selecting boat's movement at the destination (or last) waypoint

You can select how to go to the destination waypoint (last waypoint in route navigation). For NAV mode, own ship's position L/L data and waypoint L/L data are required.

1. In the NAV mode, press the [MENU] key to show the NAV mode menu.

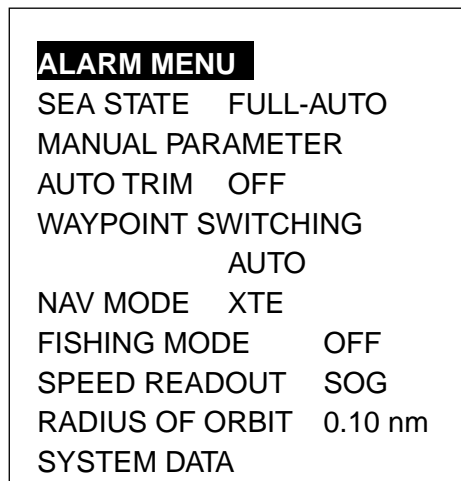

*NAV mode menu*

2. Rotate the [ENTER] knob to select "FISHING MODE", and then press the [ENTER] knob to show the fishing options window.

### 3. STEERING MODES

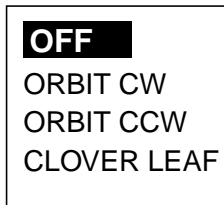

#### *Fishing mode options window*

3. Rotate the [ENTER] knob to select option desired.

- OFF:** The NAV mode changes to the AUTO mode when the boat arrives to the (last) waypoint, and the boat keeps the course at the moment of arriving the waypoint.
- ORBIT CW:** The boat runs around the (last) waypoint clockwise.
- ORBIT CCW:** The boat runs around the (last) waypoint counterclockwise.
- CLOVER LEAF:** When passing the (last) waypoint over the distance "d" as shown below, the boat repeats to return to the waypoint automatically. The distance "d" is set on menu. (See next page.)

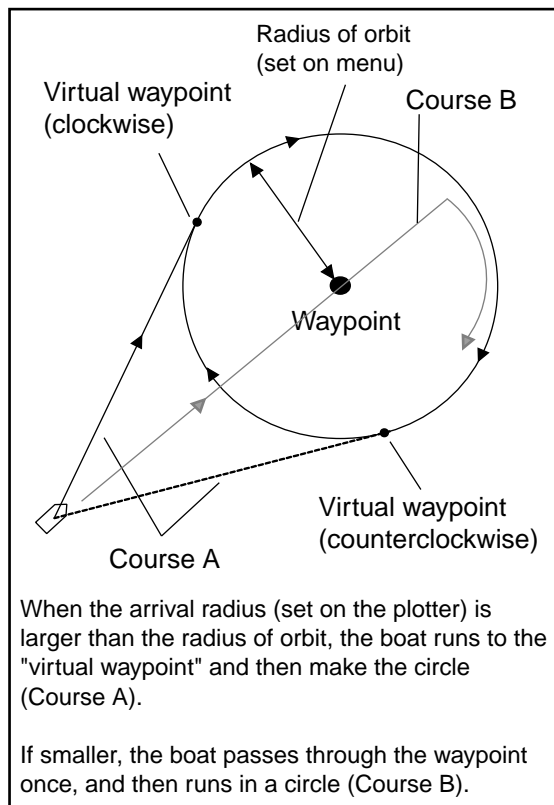

Orbit mode (ex. clockwise)

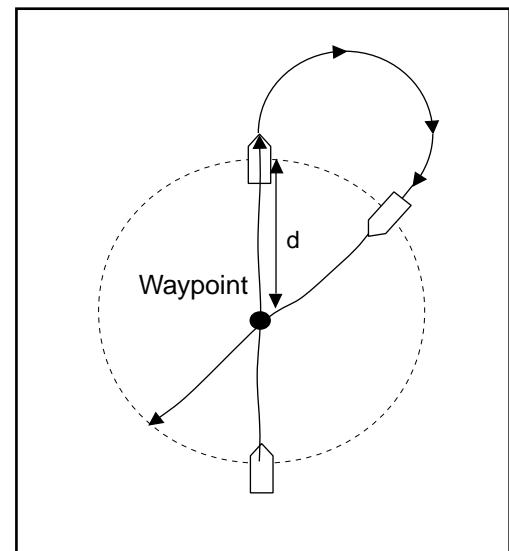

Clover leaf mode

4. Press the [ENTER] knob and [MENU] key in order to close the menu.

**Note:** Modes, ORBIT CW, ORBIT CCW and CLOVER LEAF may be changed to other while a mode activates, but it effects the next time you use the mode.

**ORBIT mode**

When selecting the ORBIT CW or ORBIT CCW, operate the autopilot as shown below.

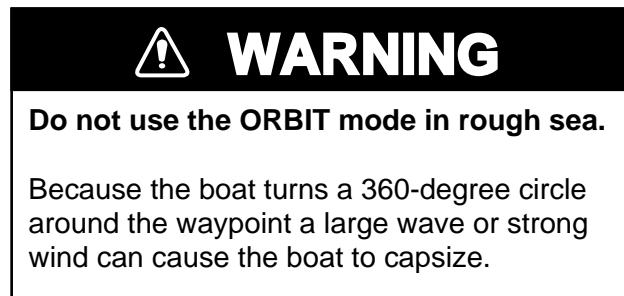

1. Set the arrival alarm range on at the plotter connected.
2. In the NAV mode, press the [MENU] key to show the NAV mode menu.
3. Rotate the [ENTER] knob to select "RADIUS OF ORBIT", and then press the [ENTER] knob.

The current value is circumscribed with a double rectangle.

4. Rotate the [ENTER] knob to set the radius for orbit.  
(Setting range: 0.05 to 9.99 nm).

The radius of orbit may be changed while the orbit mode activates.

5. Press the [ENTER] knob and [MENU] key in order to close the menu.
6. Start the waypoint (or route) navigation.

When the boat arrives in the arrival alarm range for the destination waypoint (or the last waypoint in route navigation), the message "TOO FAST TO ORBIT. PLEASE SLOW DOWN LESS THAN 10 kt." appears.

7. Reduce boat's speed less than 10 kt.

When speed becomes less than 10 kt, the message "START TO TURN BY ORBIT MODE" appears and then, the boat starts the orbital running.

**Note:** The ORBIT mode cannot function if ship's speed is more than 10 kt.  
Reduce boat speed exactly.

To quit the ORBIT mode before it is actuated, that is, the message in step 6 appears, press any key. The steering mode changes to the AUTO.

8. To escape from the ORBIT mode while it is in use, press [STBY] or [AUTO] key to change to the appropriate mode.

### **CLOVER LEAF**

For the CLOVER REAF mode, set the distance “d” shown in the figure on page 3-8 for orbit at the NAV mode menu, referring to steps 2 through 5 in the above.

**Note:** Reduce boat’s speed less than 10 kt to activate this function.

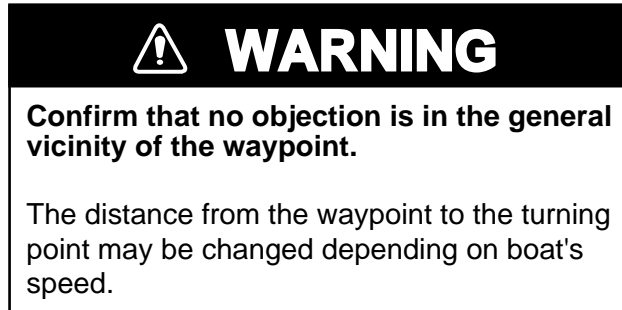

### **3.3.5 Navigating to TLL point (FISHING mode)**

When TLL (Target Latitude and Longitude) data is input from a radar or echo sounder connected in the STBY, AUTO or NAV mode, the “FISHING MODE” window appears. Then, you may choose how to progress towards that position, from ORBIT (clockwise, counterclockwise) or CLOVER LEAF. (You may also continue current steering mode, by choosing OFF.) For this mode, own ship’s position L/L data and waypoint L/L data are required. For details, see pages 3-6 and 3-7.

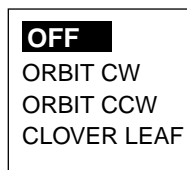

*Fishing mode window*

### **ORBIT**

The boat makes circles around the TLL point. The orbital radius is set on the menu. “ORBT” appears on the display when using the ORBIT mode.

### **CLOVER LEAF**

The boat automatically returns to the TLL position when it goes more than a distance (set on menu) away from the TLL position. The indication “CLVR” appears on the display when the CLOVER LEAF mode is in use.

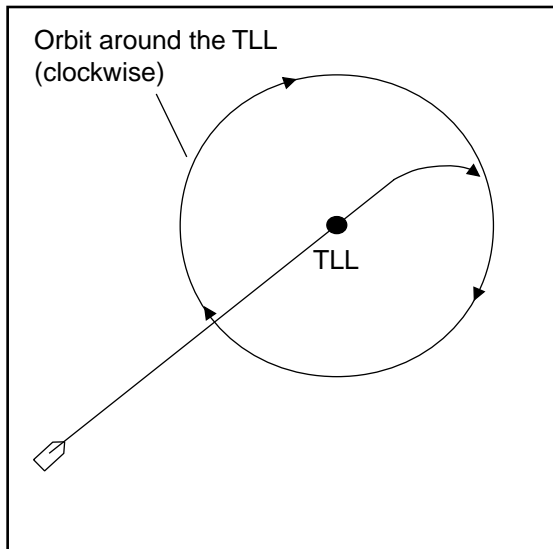

Orbit mode (ex. clockwise)

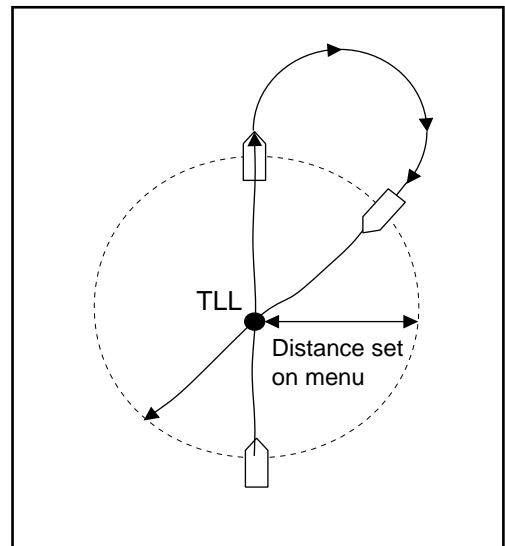

Clover leaf mode

### 3.4 REMOTE Mode

Four types of optional remote controllers may be connected to the NAVpilot-500. These are useful to operate this equipment from a remote location.

#### Dial type remote controller (FAP-5551, 5552)

This remote controller can only be used when in the AUTO or NAV mode.

1. Turn on the remote controller switch to show "FU" (Follow-Up) on the control unit. If the remote controller switch is turned on when in the STBY mode, a beep sounds to alert you that remote mode is available.



Turning power on (dial type)

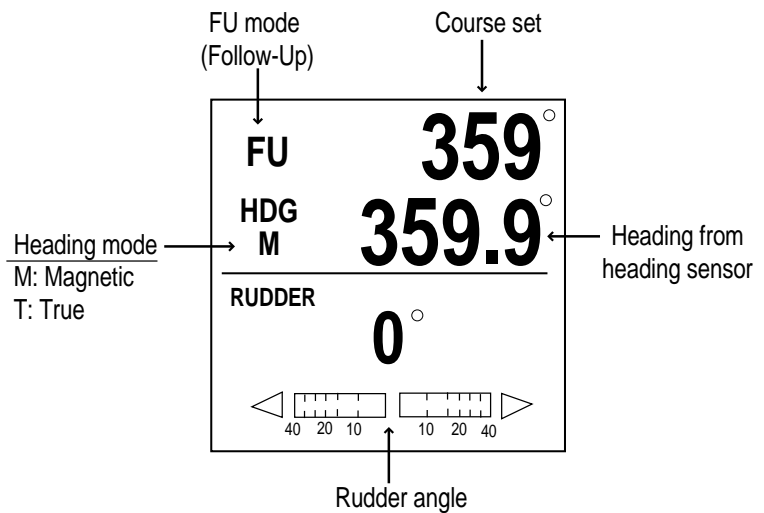

FU (Follow-Up) mode display (dial remote controller)

### 3. STEERING MODES

FU is one of manual steering modes, which outputs an absolute value determined with the [ENTER] knob to drive the rudder, thus changing the ship's course at a given rate of change towards a set point. One click of button changes the course by a definite step.

2. Rotate the dial on the remote controller to steer the rudder.  
The angle must be more than 10°, otherwise no steering occurs.



*Rotating dial*

3. When you terminate the REMOTE mode, turn off the remote controller.



*Turning power off (dial type)*

The control is returned to the control unit and the previously used mode (AUTO or NAV) is restored. For the NAV mode, the boat will go to the destination waypoint set using a sailing method (COURSE or XTE) depending on your menu selection.

**Button (FAP-6211, 6212), Lever (FAP-6221, FAP-6222),****Dodge (FAP-6231, 6232) type remote controller**

These controllers may be used in the STBY, AUTO and NAV modes.

1. For button and lever type remote controllers, turn on the remote controller power.

The dodge type remote controller doesn't have the power switch, it can be operated by simply pressing the direction keys.

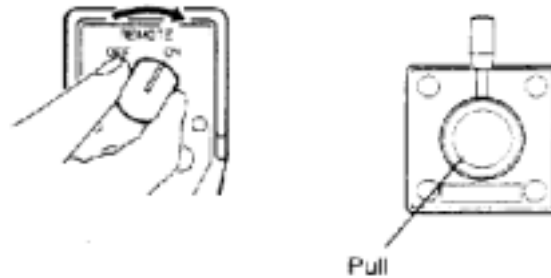

*Turning power on, button and lever type remote controllers*

The indication "NFU" (No Follow-Up) appears on the control unit. (For dodge type, NFU appears while a direction key on it is pressed.)

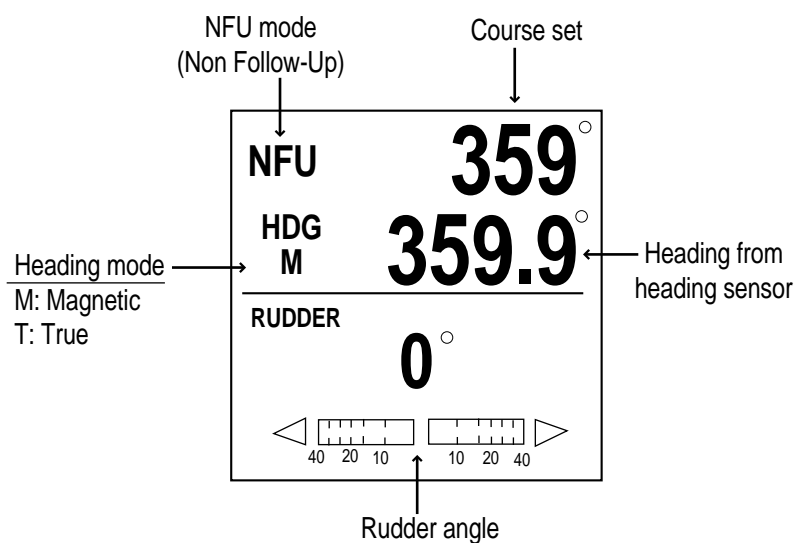

*NFU (No Follow-Up) mode display*

Non-Follow up (NFU) is one of manual steering modes where the rudder changes so long as the button or lever is operated, normally, while the lever or push button is kept pressed at local or remote place.



### 3. STEERING MODES

2. For button and dodge remote controllers, press the [PORT] or [STBD] key on the remote controller. For the lever type, position the lever for the direction.

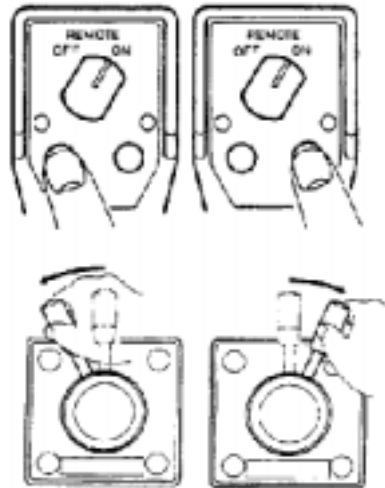

*Operating remote controller (ex. button and lever types)*

3. For the button and lever type remote controllers, turn off the remote controller when terminating the REMOTE mode. (For dodge type remote controller, simply release a key.) Control is returned to the control unit and the previously used mode (STBY, AUTO or NAV) is restored.

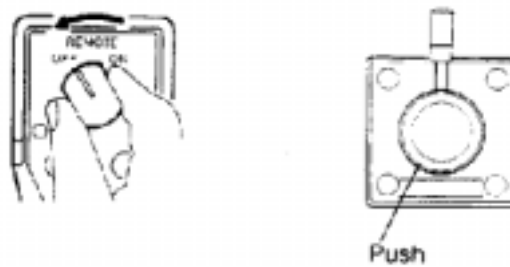

*Turning power off, button and lever type remote controllers*

**Selecting course after the REMOTE mode is off**

After the remote controller is turned off in the AUTO mode, the course mode can be chosen to follow as below.

1. In the STBY mode, press the [MENU] knob to show the STBY mode menu.

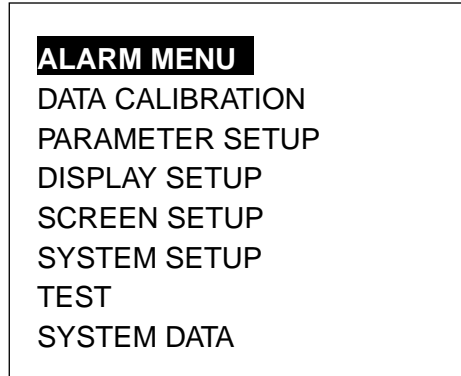

*Stby mode menu*

2. Rotate the [ENTER] knob to select "SYSTEM SETUP", and then press the [ENTER] knob to show the SYSTEM SETUP menu.

To switch page 1 and 2, select "NEXT PAGE" or "PREVIOUS PAGE" and press the [ENTER] knob.

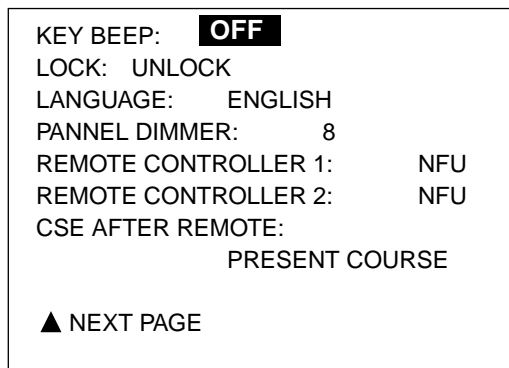

Page 1

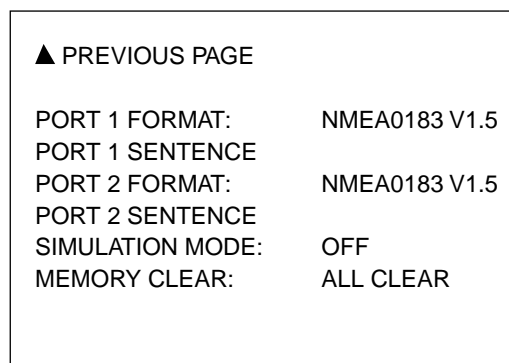

Page 2

*System setup menu*

### 3. STEERING MODES

3. Rotate the [ENTER] knob to select "CSE AFTER REMOTE", and then press the [ENTER] knob to show the cse (course) after remote options window.

<b>PREVIOUS COURSE</b>
PRESENT COURSE

*Cse (course) after remote options window*

**PREVIOUS COURSE:** The previous course before using the remote controller.

**PRESENT COURSE:** The heading at the moment the remote controller is turned off.

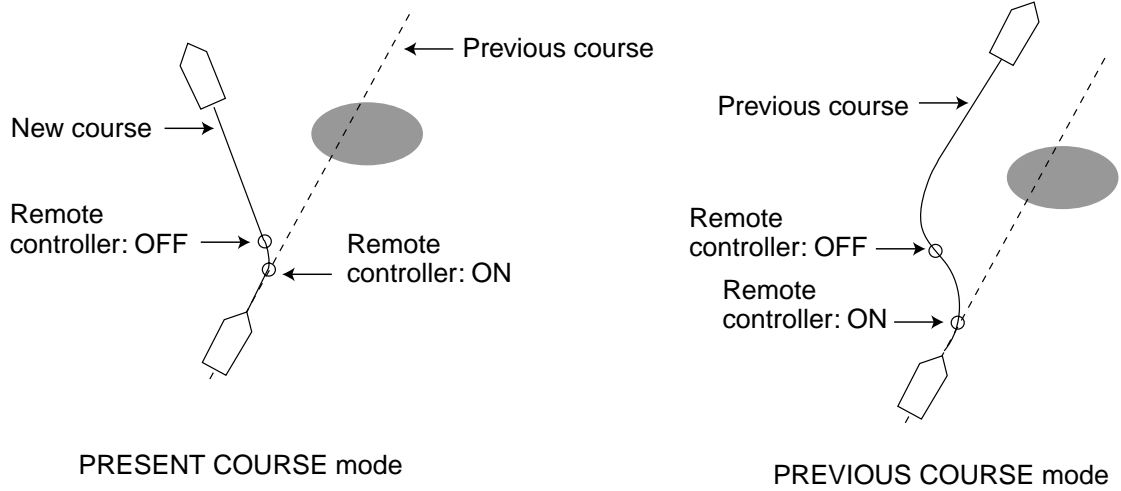

*Course after remote controller is turned off*

4. Rotate the [ENTER] knob to select PRESENT COURSE or PREVIOUS COURSE as appropriate.
5. Press the [ENTER] knob and [MENU] key in order to close the menu.

## 3.5 DODGE Mode

The DODGE mode is useful in situations where you need to quickly take control of the helm to avoid an obstruction.

### 3.5.1 Dodging in STBY mode

1. Press the [PORT] or [STBD] key down to steer appropriately until the boat finishes the turning.

The equipment goes into the DODGE mode while pressing the [PORT] or [STBD] key. In this mode, steering can not be done from other control units or remote controllers. Further the audible alarm sounds when one of the above keys is operated, to alert you to dodge operation. Note also that "DODG" appears on the display.

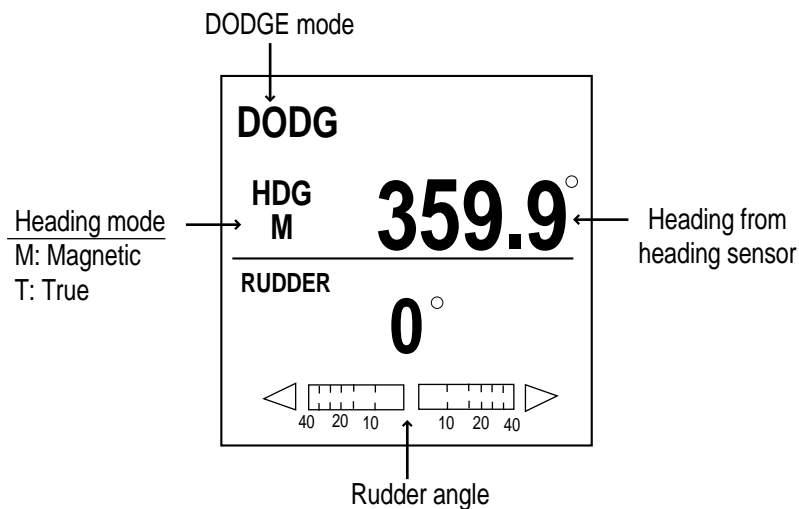

*Dodge mode display 1*

**Note:** To move the rudder to 0° point, press the [PORT] and [STBD] keys at the same time.

2. Release the [PORT] or [STBD] key to leave from the DODGE mode.

### 3.5.2 Dodging in AUTO or NAV mode

1. Press the [PORT] or [STBD] key down to change the course until the boat finishes to avoid the obstruction.

The equipment goes into the DODGE mode and the audible alarm sounds when one of the above keys is operated, to alert you to dodge operation. Note also that "DODG" appears on the display.

**Note:** Press the [PORT] and [STBD] keys together to fix the course setting value.

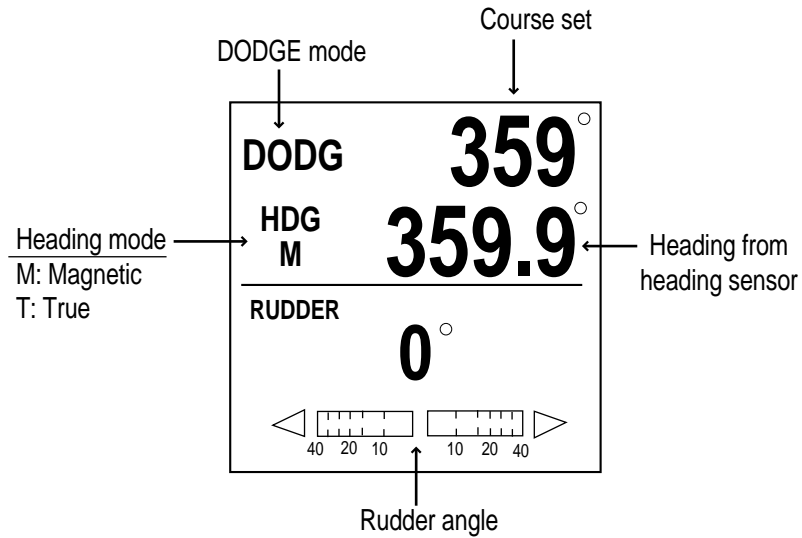

*Dodge mode display 2*

2. Release the key pressed to return to the previous mode (AUTO or NAV).  
You can operate the autopilot with the status before the DODGE mode.

# 4. MENU OPERATION

---

Most settings are carried out on the menus. The items shown depend on the mode in use. For the STBY mode the complete menu is shown. In case of the AUTO or NAV mode the items most often adjusted in the corresponding mode are shown.

The ALARM menu description is shown on Chapter 5.

## 4.1 STBY Mode Menu

On the STBY mode, press the [MENU] key to show the STBY mode menu. This menu has the complete menu items.

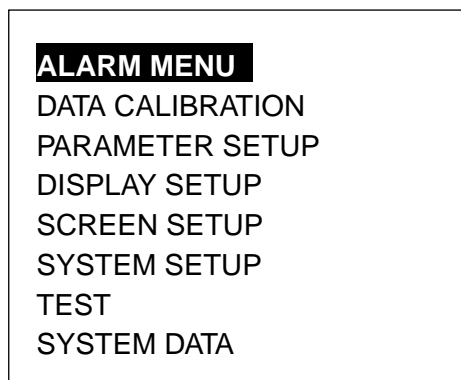

*STBY mode menu*

### 4.1.1 Offsetting data

The DATA CALIBRATION menu permits calibrating heading, magnetic deviation, speed, temperature and depth data to further refine accuracy.

Rotate the [ENTER] knob to select DATA CALIBRATION and press the [ENTER] knob to show the DATA CALIBRATION menu.

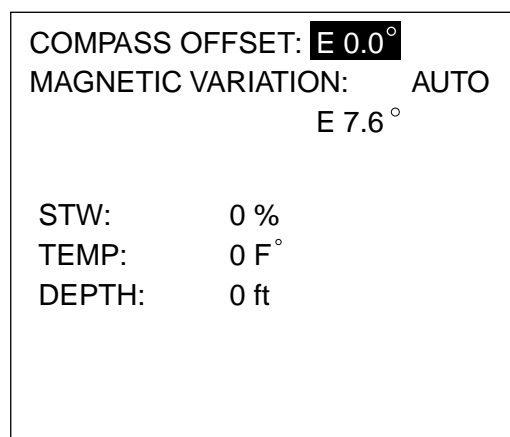

*Data calibration menu*

## 4. MENU OPERATION

### **Offsetting the heading data**

Offset the heading data received from the heading sensor if the heading data shown on the control unit differs from the indication of the ship's compass. This offset is applied to the heading sensor data. When the control unit shows 125° though the ship's compass reading is 120°, for example, enter "5".

1. Rotate the [ENTER] knob to select "COMPASS OFFSET" from the DATA CALIBRATION menu.
2. Press the [ENTER] knob and the current value is circumscribed with a double rectangle.
3. Rotate the [ENTER] knob to set the offset value (W180.0° to E180.0°).
4. Press the [ENTER] knob to finish.

### **Selecting the selecting method of magnetic variation**

When connecting with a magnetic heading sensor (PG-500 etc.), the magnetic variation is necessary to use true heading data. The Furuno plotter or navigation outputs magnetic variations for all areas of the earth. You may choose to use the preprogrammed variations or enter variations manually, in case of no plotter or you prefer to enter them manually.

1. Rotate the [ENTER] knob to select "MAGNETIC VARIATION" from the DATA CALIBRATION menu.
2. Press the [ENTER] knob to show the magnetic variation options window.



*Magnetic variation options window*

3. Rotate the [ENTER] knob to select AUTO or MANUAL.
4. Press the [ENTER] knob.
5. When selecting MANUAL, rotate the [ENTER] knob to select next line, and then set the variation value, consulting a nautical chart, by using the [ENTER] knob. (W99.9° to E99.9°)
6. Press the [ENTER] knob to finish.

### **Ship's speed, temperature, depth calibration**

Refer to the Installation manual.

### 4.1.2 Setting parameters

The PARAMETER SETUP menu sets various parameters for the control of the NAVpilot-500.

1. On the STBY mode, press the [MENU] key to open the STBY mode menu.
2. Rotate the [ENTER] knob to select "PARAMETER SETUP".
3. Press the [ENTER] knob to show the PARAMETER SETUP menu.

SEA STATE:	<b>FULL-AUTO</b>
DEVIATION LEVEL:	AUTO
MANUAL PARAMETER	
AUTO TRIM:	OFF
ADVANCED AUTO:	NO
NET TOWING AUTO:	NO
NAV MODE:	XTE
RADIUS OF ORBIT:	1.00 nm
FISHING MODE:	OFF
WAYPOINT SWITCHING:	AUTO

*Parameter setup menu*

4. To close the PARAMETER SETUP menu, press the [MENU] key.

#### **Selecting the method of entering the parameter**

The NAVpilot-500 has an automatic adjustment feature which sets up the equipment according to ship's characteristics and sea state for optimum performance in the AUTO and NAV modes. Further, a self-learning algorithm is incorporated: Parameters for rudder ratio, counter rudder and auto trim gains, input at the sea trial after the installation and experiences of your boat, are stored in memory for navigation in the future.

Note that the default settings for FULL-AUTO have been detected based on the BOAT TYPE and BOAT LENGTH on installing.

You may set sea state as follows:

1. Rotate the [ENTER] knob to select "SEA STATE" from the PARAMETER SETUP menu.
2. Press the [ENTER] knob to show the sea state options window.

<b>FULL-AUTO</b>
SEMI-AUTO
MANUAL-CALM
MANUAL-MODERATE
MANUAL-ROUGH

*Sea state options window*



#### 4. MENU OPERATION

3. Rotate the [ENTER] knob to select FULL-AUTO, SEMI-AUTO, MANUAL-CALM, MANUAL-MODERATE or MANUAL-ROUGH as appropriate, and then press the [ENTER] knob.

FULL-AUTO: Auto adjustment and self-learning are on.

SEMI-AUTO: Auto adjustment is on, self-learning is off.

MANUAL-CALM: Self-learning is off, using the parameter selected for calm sea.

MANUAL-MODERATE: Self-learning is off, using the parameter selected for normal sea state.

MANUAL-ROUGH: Self-learning is off, using the parameter selected for rough sea.

When you want to use the NAVpilot-500 with the experience-related parameters, choose the SEMI-AUTO option.

However, note that the course keeping quality may be decreased if the sea state is different from that in the experience-related parameters.

In that case we recommend that you set the autopilot in the FULL-AUTO option.

For MANUAL-CALM, MODERATE or ROUGH, set MANUAL PARAMETER shown on next page.

4. When selecting "FULL-AUTO" at step 3, set DEVIATION LEVEL as follows:
  - a) Rotate the [ENTER] knob to select "DEVIATION LEVEL".
  - b) Press the [ENTER] knob to show the deviation level options window.



*Deviation level options window*

- c) Rotate the [ENTER] knob to select "AUTO" or "LEVEL" as appropriate. For LEVEL, you may set a value between 1 and 9. A lower number keeps the course more exactly, but the rudder may be turned more often. In a higher number, the rudder is fixed, but the course may be changed frequently.
  - d) Press the [ENTER] knob to close the window.
5. Press the [ENTER] knob to finish.

### Setting parameters manually

When MANUAL-CALM, MODERATE or ROUGH is selected at the previous paragraph, set MANUAL PARAMETER as below.

You can set three parameters for MANUAL function: Weather, Rudder gain and Counter rudder.

The default manual parameters provide for comfortable steering of a boat 35 feet in length at the speed of 10 kt. When speed is increased to 20 kt, the manual parameters are automatically reduced 66%.

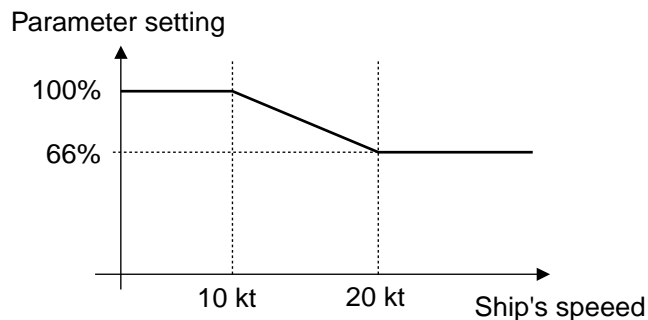

1. Rotate the [ENTER] knob to select MANUAL PARAMATER from the PARAMETER SETUP menu.
2. Press the [ENTER] knob to show the following table.

#### Example of Manual parameter

	SEA STATE		
	C	M	R
WEATHER	1°	2°	3°
RUDDER GAIN	0.4	0.5	0.6
COUNT RUDDER	0.2	0.3	0.4

C: CALM, M: MODERATE, R: ROUGH

If the length of your boat is longer or shorter than 35 feet, set the manual parameters as follows:

Boat longer than 35 feet: Set parameters smaller than default parameters.

Boat shorter than 35 feet: Set parameters larger than default parameters.

3. Rotate the [ENTER] knob to choose WEATHER-C (calm) setting, and then press the [ENTER] knob.
4. Rotate the [ENTER] knob to set value (Setting range: 1° to 10° for weather).
5. Press the [ENTER] knob.
6. Set WEATHER-M (moderate), WEATHER-R (rough) and RUDDER GAIN and COUNT RUDDER similarly (Setting range: 0.1 to 2.0 for rudder gain, 0.1 to 4.0 for counter rudder).
7. Press the [MENU] key to close the table.

## 4. MENU OPERATION

### WEATHER

When the sea is rough, the boat's heading fluctuates to port and starboard. If the rudder is driven very often to maintain the set course, the helm mechanism may wear out. To prevent this, the weather adjustment makes the NAVpilot-500 insensitive to minute course deviations. You may choose a degree between 1° to 10°. Until the course deviation exceeds the selected setting, steering to correct the heading will not be initiated.

The illustration below shows boat's track lines with weather setting 3° and 7°. When 7° is set, for example, the rudder is not driven until the course deviation exceeds 7°. Increasing the setting reduces activation of the steering gear, however the boat tends to zigzag. When the sea is calm, set a smaller value.

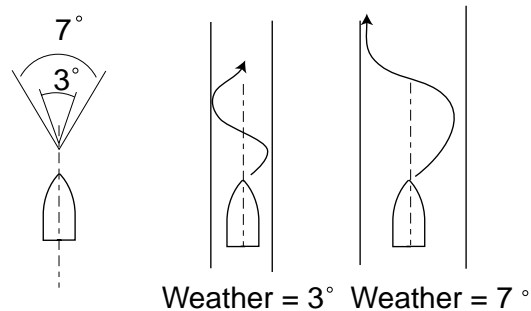

*Track line and weather setting value*

### RUDDER GAIN

When the boat's heading deviates from the set course, the NAVpilot-500 adjusts the rudder to correct it. The rudder angle (number of degrees) which is steered against every degree of course deviation is known as the rudder gain.

The following illustrations show how many degrees the NAVpilot-500 steers the rudder in order to nullify 10 degrees of course deviation with various settings of the rudder gain.

Rudder gain = 0.1

Rudder gain = 0.3

Rudder gain = 0.8

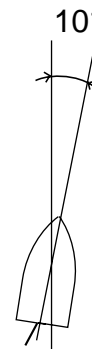
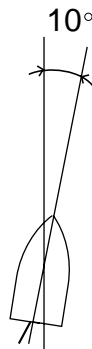

$$\text{Rudder angle} = 10^\circ \times 0.1 = 1^\circ \quad \text{Rudder angle} = 10^\circ \times 0.3 = 3^\circ \quad \text{Rudder angle} = 10^\circ \times 0.8 = 8^\circ$$

*Rudder angle and rudder gain setting*

Set rudder gain so that the boat does not make frequent yaw. The figure shown below provides general guidelines for setting rudder gain.

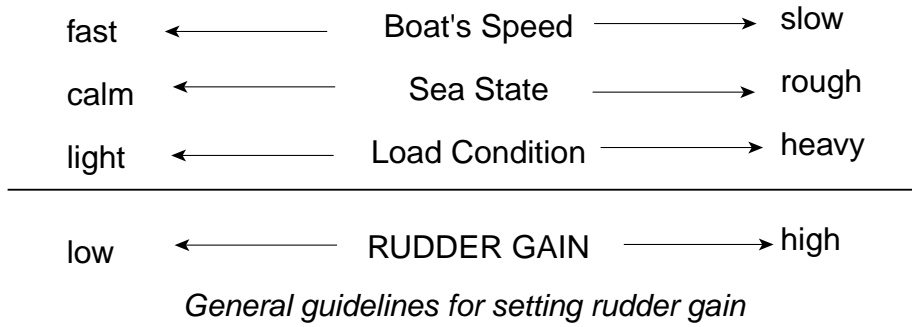

**COUNTER RUDDER**

If the boat is heavily loaded, the heading will turn excessively by inertia, passing the new course. Then, the NAVpilot-500 will steer the rudder to the opposite side and the heading will turn in that direction excessively again. In an extreme case the heading oscillates several times until it finally settles in the new course. An adjustment known as “counter rudder” prevents this kind of oscillation.

Counter rudder is usually not required for small boats. When your boat zigzags a lot before settling in the new course, increase the setting.

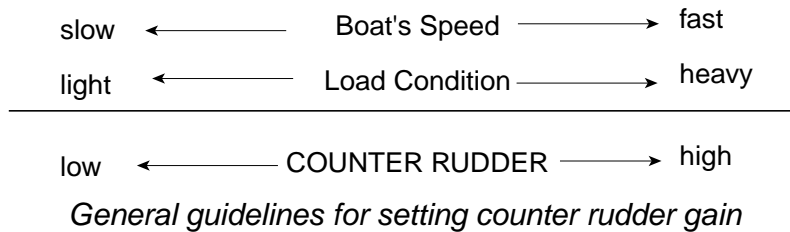
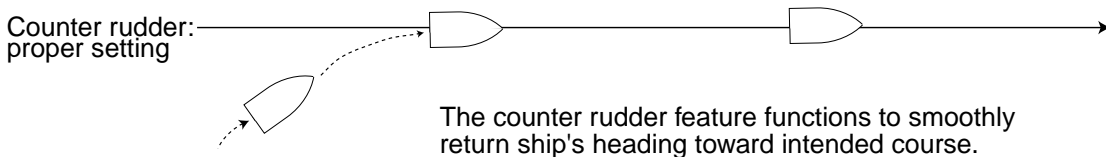
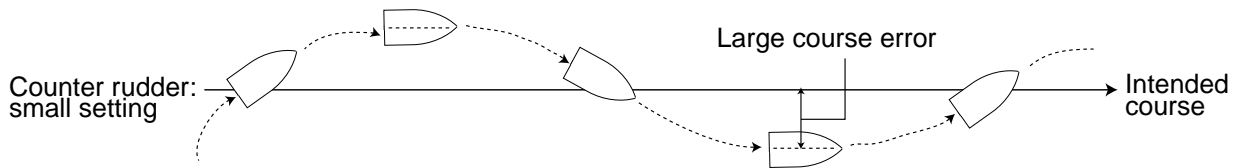

## 4. MENU OPERATION

### **Adjusting the sensitivity in monitoring the boat's trim**

The NAVpilot-500 continually monitors the boat's trim in order to keep the trim sensitivity optimum. A lower setting is common because boat's trim usually does not change quickly. A large number changes the trim compensation value more frequently. Too high a setting may result in the following problems.

- Trim sensitivity is over-affected, resulting that a trim appears in both port and starboard directions alternately.
- Trim compensation mechanism responds to the yawing, resulting in more serious oscillation of ship's heading.

To set the auto trim sensitivity:

1. Rotate the [ENTER] knob to select AUTO TRIM from the PARAMETER SETUP menu.
2. Press the [ENTER] knob to show the auto trim options window.



*Auto trim options window*

3. Rotate the [ENTER] knob to select "ON".
4. Press the [ENTER] knob.
5. Rotate the [ENTER] knob to select current value.
6. Press the [ENTER] key and the current value is circumscribed with a double rectangle.
7. Rotate the [ENTER] knob to set value (Setting range: 1 to 100, the default setting is calculated automatically depending on the ship's length entered on the DOCK SIDE SETUP menu.)
8. Press the [ENTER] knob to finish.

**When towing the net**

When a boat is in tow of the fishing gear, its stern is “dragged” by the net. This causes the boat to stray from its intended course. To keep the boat on course, you need to adjust the trim manually, which can be bothersome. If you do not want to be bothered with trim adjustments, you can enable the automatic towing function to have the trim automatically adjusted. It is indispensable for trawlers and purse seiners.

1. Rotate the [ENTER] knob to select “AUTO NET TOWING” from the PARAMETER SETUP menu.
2. Press the [ENTER] knob to show the net towing options window.



*Auto net towing options window*

3. Rotate the [ENTER] knob to select ON or OFF as appropriate.
4. Press the [ENTER] knob to finish.

## 4. MENU OPERATION

### 4.1.3 Setting the units of measurements

The DISPLAY SETUP menu allows you to choose units of measurement.

1. Press the [STBY] and [MENU] key in order to open the STBY mode menu.
2. Rotate the [ENTER] knob to select "DISPLAY SETUP".
3. Press the [ENTER] knob to show the display setup menu.

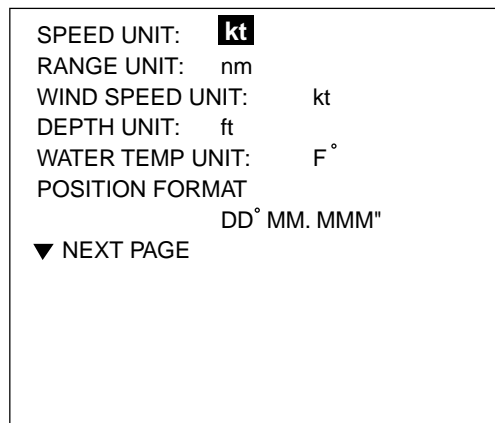

Page 1

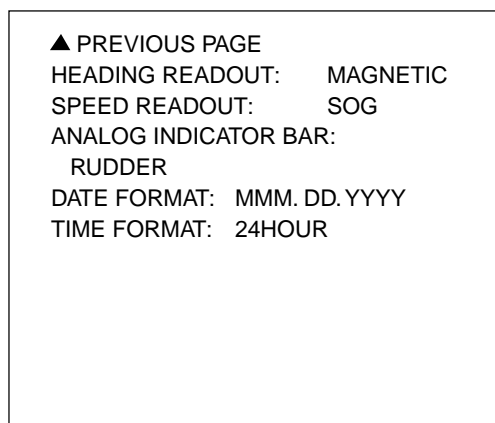

Page 2

#### *Display setup menu*

To change pages, select "▼ NEXT PAGE" or "▲ PREVIOUS PAGE" and press the [ENTER] knob.

4. Rotate the [ENTER] knob to select the item desired.
5. Press the [ENTER] knob to show the speed unit options window. The example below shows the speed unit options.

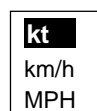

*Speed unit options window, for example*

6. Rotate the [ENTER] knob to select option. See the table shown below detailed information.
7. Select other units of measurement as appropriate, referring to the table shown below.
8. Press the [ENTER] knob to finish.

Item	Description	Settings
Speed Unit	Choose unit of ship's speed measurement.	kt, km/h, MPH
Range Unit	Choose unit of range measurement.	nm, km, sm, nm & yd, nm & m, km & m, sm & yd
Wind Speed Unit	Choose unit of wind speed measurement.	kt, km/h, m/s, MPH
Depth Unit	Choose unit of depth measurement.	ft, m, FA, P/B (P/B=Passi/Braza)
Water Temp Unit	Choose unit of water temperature measurement.	°F, °C
Position Format	Choose how many digits (or seconds) to display after decimal point in latitude and longitude position.	DD°MM.MM', DD°MM.MMM', DD°MM.MMMM', DD°MM. SS.S"
Next Page		
Previous PAGE		
Heading Readout	Choose heading display format.	Magnetic, True
Speed Readout	Choose speed format to display. When selecting Manual, enter the speed manually.	SOG (Speed over ground), STW (Speed through water), Manual
Analog Indicator Bar	Choose what to display on the bar indicator display on Normal display 1 and 2.	Rudder angle, Deviation, Rudder/XTE (Rudder in STBY and AUTO mode, XTE in NAV mode), Deviation/XTE (Deviation in STBY and AUTO mode, XTE in NAV mode)
Date Format	Choose the date display format.	DD. MMM. YYYY, YYYY. MM. DD, MMM. DD. YYYY
Time Format	Choose the time display format.	12 HOUR, 24 HOUR



## 4. MENU OPERATION

### 4.1.4 Setting other menu items

The SYSTEM SETUP menu allows you to set various item according to your operating needs.

1. Open the STBY mode menu.
2. Rotate the [ENTER] knob to select "SYSTEM SETUP".
3. Press the [ENTER] knob to show the SYSTEM SETUP menu.

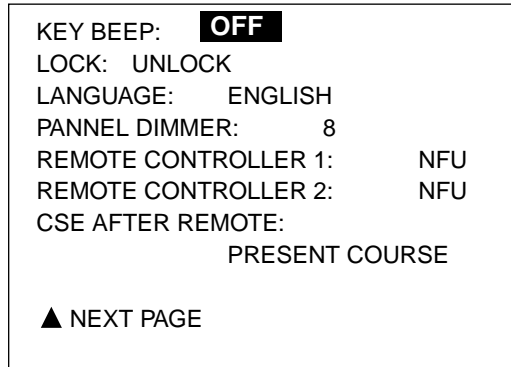

Page 1

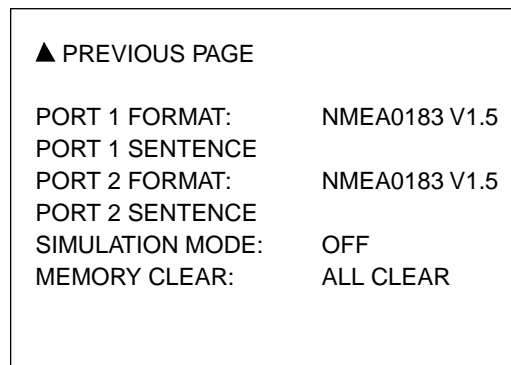

Page 2

#### *System setup menu*

To change pages, select "▼NEXT PAGE" or "▲PREVIOUS PAGE" and press the [ENTER] knob.

#### **Activating key beep**

Turn the key beep on or off.

1. Rotate the [ENTER] knob to select "KEY BEEP" on the SYSTEM SETUP menu.
1. Press the [ENTER] knob to show the key beep options window.



#### *Key beep options window*

3. Rotate the [ENTER] knob to select ON or OFF as appropriate.
4. Press the [ENTER] knob.

**Locking the control unit**

The LOCK feature renders the following commands inoperative from the control unit at which the LOCK feature has been actuated.

- Menu operation
- Changing the steering mode
- Course setting
- Waypoint switching

1. Rotate the [ENTER] knob to select "LOCK" from the SYSTEM SETUP menu.
2. Press the [ENTER] knob to show the lock options window.



*Lock options window*

3. Rotate the [ENTER] knob to select "LOCK" or "UNLOCK" as appropriate.
4. Press the [ENTER] knob.

To unlock, press the [STBD] (▶) key while holding the [MENU] key down.

**Selecting language**

Select the language to use, from between English and some European languages.

1. Rotate the [ENTER] knob to select "LANGUAGE" from the SYSTEM SETUP menu.
2. Press the [ENTER] knob to show the language options window.
3. Rotate the [ENTER] knob to select the language desired.
4. Press the [ENTER] knob.

**Setting the panel dimmer**

You can adjust the control panel dimmer as follows.

1. Rotate the [ENTER] knob to select "PANEL DIMMER" from the SYSTEM SETUP menu.
2. Press the [ENTER] knob and the current value is circumscribed with a double rectangle.
3. Rotate the [ENTER] knob to set value (Setting range: 1 to 8). The higher the number the greater the illumination.
4. Press the [ENTER] knob.

## 4. MENU OPERATION

### Running simulation program

The simulation mode, for use by service technicians for demonstration purposes, provides simulated operation to help acquaint users with the many features of the NAVpiloy-500. It allows you to view and control a simulated autopilot without position-fixing equipment. Most controls are operative, thus you may practice how to use the Navpilot-500. You may turn the simulation mode on or off as follows:

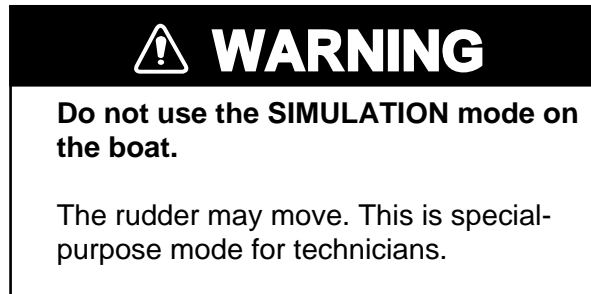

Available steering mode	AUTO, NAV, DODGE mode
Available operation	Heading, Rudder angle, Alarms, Waypoint switch, Wind data, Depth, Speed, Time

1. Rotate the [ENTER] knob to select "SIMULATION MODE" from the SYSTEM SETTING menu.
2. Press the [ENTER] knob to show the simulation mode options window.

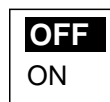

*Simulation mode options window*

3. Rotate the [ENTER] knob to select ON or OFF as appropriate.
4. For "ON", enter the course value manually using the [ENTER] knob.
5. Press the [ENTER] knob.

In the simulation mode, the message "SIM" blinks on any display.

# 5. ALARMS

## 5.1 ALARM Menu

The NAVpilot-500 has seven conditions which generate both audio and visual alarms: watch alarm, deviation alarm, XTE (cross-track error) alarm, speed alarm, depth alarm, temp alarm and log trip alarm. You may set up the alarms on the ALARM menu.

1. Press the [MENU] key to show the mode menu.
2. Rotate the [ENTER] knob to select "ALARM MENU".
3. Press the [ENTER] knob to show the ALARM menu.

Page 1

AUDIO ALARM:	
<b>INTERNAL BUZZER</b>	
ALARM INTERVAL:	SHORT
WATCH ALARM:	OFF
DEVIATION ALARM:	30
XTE ALARM:	OFF
▼ NEXT PAGE	
ALARM MESSAGE 1 EXCEED XTE LIMIT	NOT CONFIRMED

Page 2

<b>▲ PREVIOUS PAGE</b>	
SPEED ALARM:	OFF
DEPTH ALARM:	OFF
TEMP ALARM:	OFF
TRIP LOG:	OFF
CLEAR TRIP LOG:	NO
ALARM MESSAGE 1 EXCEED XTE LIMIT	NOT CONFIRMED

*Alarm menu*

4. To reach page 2, select "▼ NEXT PAGE" and then press the [ENTER] knob.
5. Press the [MENU] key to close the ALARM menu.

### 5.1.1 Selecting the alarm buzzer

You may choose the buzzer from which to output the audio alarm as follows.

1. Rotate the [ENTER] knob to select "AUDIO ALARM" from the ALARM menu.
2. Press the [ENTER] knob to show the audio alarm options window.



*Audio alarm options window*

3. Rotate the [ENTER] knob to select INTERNAL BUZZER or INTERNAL+EXTERNAL BUZZER as appropriate.  
INTERNAL BUZZER: Sounds the buzzer in the control unit.  
INTERNAL+EXTERNAL BUZZER: Sounds the control unit buzzer and external buzzer if connected.
4. Press the [ENTER] knob.

### 5.1.2 Selecting the beep pattern

The sound pattern of the audio alarm can be selected as follows.

1. Rotate the [ENTER] knob to select "ALARM INTERVAL" from the ALARM menu.
2. Press the [ENTER] knob to show the alarm interval options window.



*Alarm interval options window*

3. Rotate the [ENTER] knob to select SHORT, LONG or CONTINUE as appropriate.

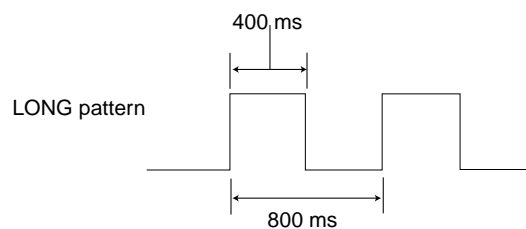
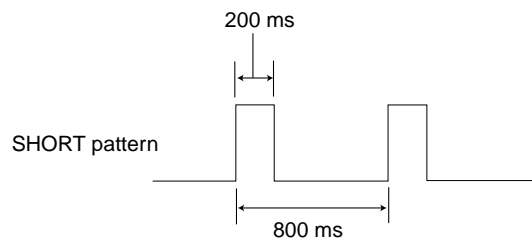

CONTINUE: Beep sounds continuously.

4. Press the [ENTER] knob.

### 5.1.3 Setting the watch alarm

The watch alarm periodically warns the helmsman to check the autopilot when in the AUTO or NAV mode.

1. Rotate the [ENTER] knob to select "WATCH ALARM" from the ALARM menu.
2. Press the [ENTER] key to show the watch alarm options window.



*Watch alarm options window*

3. Rotate the [ENTER] knob to select "ON" or "OFF" as appropriate.  
When selecting "ON", you can set the time interval (1 to 10 min) at which to be alerted. If the set time passes without operation, the alarm sounds. Further, if three minutes elapse after the watch alarm has sounded, the message "TOUCH ME" appears. Press any key to clear the alarm.
4. Press the [ENTER] knob.

### 5.1.4 Setting the heading deviation alarm

The deviation alarm sounds when the heading deviates more than a limit set than the current heading in the AUTO or NAV mode.

1. Rotate the [ENTER] knob to select "DEVIATION ALARM" from the ALARM menu.
2. Press the [ENTER] knob and the current value is circumscribed with a double rectangle.
3. Rotate the [ENTER] knob to set the degree of deviation (Setting range: 1 to 90°).
4. Press the [ENTER] knob.

### 5.1.5 Setting the cross-track error limit

The XTE alarm sounds, in the NAV mode, when the course error has exceeded or within the range set.

1. Rotate the [ENTER] knob to select "XTE ALARM" from the ALARM menu.
2. Press the [ENTER] knob to show the XTE alarm options window.



*XTE alarm options window*

## 5. ALARMS

3. Rotate the [ENTER] knob to select "OFF", "OUT" or "INTO" as appropriate.  
OFF: Turn the XTE alarm off.  
OUT: The alarm is released when exceeding the XTE range is exceeded.  
INTO: The alarm is released when the course error is within the XTE range.  
For OUT or INTO, set the range (0.001 to 9.999 nm/km/sm) using the [ENTER] knob.
4. Press the [ENTER] knob.

### **How to use XTE alarm (INTO mode)**

When your boat is cruising parallel to an object or area you want to avoid, for example, a reef, sandbar, etc., use the XTE alarm (INTO) to alert you when your boat is within a certain distance to the object or area.

1. On the FURUNO plotter, create a route which runs parallel to the area you wish to avoid.
2. Set the XTE alarm (INTO) range such that it is the distance to the edge of the area plus some allowance.

When your boat nears the area by the distance set above the XTE alarm sounds to alert you.

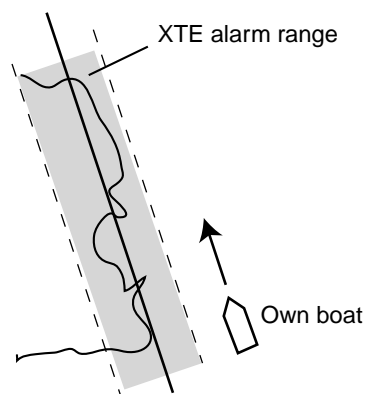

Route made at the plotter

*Application of XTE alarm*

### **5.1.6 Setting the speed alarm**

The speed alarm warns when your boat's speed is within, outside, over or under the speed range set.

1. Rotate the [ENTER] knob to select "SPEED ALARM" from the ALARM menu.
2. Press the [ENTER] knob to show the speed alarm options window.

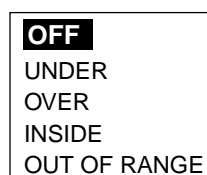

*Speed alarm options window*

3. Rotate the [ENTER] knob to select speed alarm condition.
  - OFF: Turn the speed alarm off.
  - OVER: The alarm is released when the ship's speed is over the set value.
  - UNDER: The alarm is released when ship's speed is under the set value.
  - INSIDE: The alarm released when ship's speed is within the range set.
  - OUT OF RANGE: The alarm is released when ship's speed is outside the range set.

When selecting INSIDE or OUT OF RANGE, set the upper and lower limits, using three digits. For OVER and UNDER, set value (Setting range: 0.0 to 999.9 kt, km/h or mph).
4. Press the [ENTER] knob.

### 5.1.7 Setting the depth alarm

The depth alarm sounds when the bottom is shallower, deeper, within or outside the range set. To activate the depth alarm, the depth data is necessary.

1. Rotate the [ENTER] knob to select "DEPTH ALARM" from the ALARM menu.
2. Press the [ENTER] knob to show the depth alarm options window.

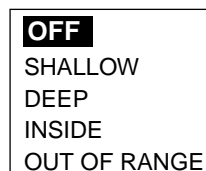

*Depth alarm options window*

3. Rotate the [ENTER] knob to select the condition.
  - OFF: Turn the depth alarm off.
  - SHALLOW: The alarm is released when the bottom is shallower than the value set.
  - DEEP: The alarm is released when the bottom is deeper than the value set.
  - INSIDE: The alarm is released when the bottom is within the range set.
  - OUT OF RANGE: The alarm released when the bottom is outside the range set.

When selecting INSIDE or OUT OF RANGE, set upper and lower limits, using three digits. For SHALLOW or DEEP, set a value (Setting range: 0 to 999.9 ft/m/FA/PB).
4. Press the [ENTER] knob.



### 5.1.8 Setting the temperature alarm

There are five types of water temperature alarms: UNDER, OVER, INSIDE, OUT OF RANGE and CURRENT RIP. The UNDER and OVER alarms sound when the water temperature is lower or higher than the value set, the INSIDE and OUTSIDE alarms sound when the water temperature is within or outside the range set. For CURRENT RIP, the alarm sounds when the temperature changes over the value set within a minute.

1. Rotate the [ENTER] knob to select TEMP ALARM from the ALARM menu.
2. Press the [ENTER] knob to show the temp alarm options window.

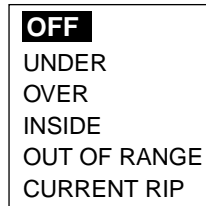

*Temp alarm options window*

3. Rotate the [ENTER] knob to select the water temperature condition.  
When selecting the INSIDE, OUT OF RANGE or CURRENT RIP, set the number for upper and lower limits, using three digits. For UNDER or OVER, set a value (Setting range: 0 to 120°F or -20 to 50°C).
4. Press the [ENTER] knob.

### 5.1.9 Setting the trip distance alarm

The log trip alarm alerts you a defined distance has been reached.

1. Rotate the [ENTER] knob to select TRIP LOG from the ALARM menu.
2. Press the [ENTER] knob to show the log trip options window.



*Log trip options window*

3. Rotate the [ENTER] knob to select "ON" or "OFF" as appropriate.  
When selecting ON, set appropriate value (Setting range: 0 to 9999 nm/km/sm).
4. Press the [ENTER] knob.

### 5.1.10 Clearing the trip distance

You can reset the trip distance to zero as follows.

1. Rotate the [ENTER] knob to select CLEAR TRIP LOG from the ALARM menu.
2. Press the [ENTER] knob to show the log trip clear options window.



*Log trip clear options window*

3. Rotate the [ENTER] knob to select "YES" to reset the trip distance.
4. Press the [ENTER] knob.

## 5.2 Alarm Information

When an alarm setting has violated, the buzzer sounds and the speaker icon appears. Press any key to silence alarm. You can see which alarm has been violated on the ALARM menu. In the example below the arrival alarm has been violated.

1. Press the [MENU] key to show the mode menu.
2. Rotate the [ENTER] knob to select ALARM MENU, and then press the [ENTER] knob to show the ALARM menu.

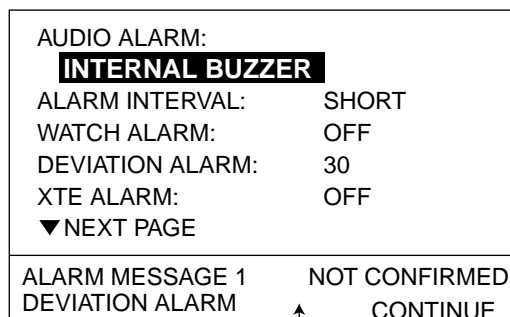

Alarm information window

*Alarm menu (page 1)*

3. Press the [TURN] key to acknowledge the alarm (and silence the buzzer if it was not done with any key). The message "NOT CONFIRMED" changes to "CONFIRMED." This is erased when the alarm is eliminated. When two or more alarms have been violated, "CONTINUE" and left and (or) right arrows appear at the bottom of the ALARM menu. The arrows indicate which key to press to display next alarm message. Press the [STBD] key to show messages of highest priority; the [PORT] key to display messages of lower priority.
4. Press the [MENU] key twice to finish.

## 5. ALARMS

### Alarm messages

The table below shows the alarm messages, their meanings and priorities.

*Alarm messages, their meanings and priorities*

Message	Meaning	Priority
DEVIATION ALARM	Deviation alarm is violated.	1
EXCEEDED XTE LIMIT	XTE alarm is violated.	2
PROCEEDED XTE ALARM		
SPEED IS OVER LIMIT	Speed alarm is violated.	3
SPEED IS UNDER LIMIT		
SPEED IS PROCEEDED BETWEEN LIMITS		
SPEED IS OUTSIDE OF LIMIT		
DEPTH IS OVER LIMIT	Depth alarm is violated.	4
DEPTH IS UNDER LIMIT		
EXCEEDED WATER TEMP. LIMIT	Temperature alarm is violated.	5
PROCEEDED WATER TEMP. LIMIT		
LOG TRIP ALARM	Log alarm is violated.	6

# 6. MAINTENANCE & TROUBLESHOOTING

This chapter provides information necessary for keeping your unit in good working order and remedying simple problems.

WARNING

**Do not open the equipment.**

Hazardous voltage which can cause electrical shock exists inside the equipment. Only qualified personnel should work inside the equipment.

## 6.1 Preventive Maintenance

Regular maintenance is important for optimum performance. A maintenance schedule should be established and should at least include the items below.

### Maintenance program

Item	Check point	Remedy
Control unit connector	Check for tight connection.	Tighten loosened connectors.
LCD	The LCD will, in time, accumulate a coating of dust which tends to dim the picture.	Wipe the LCD carefully to prevent scratching, using tissue paper and an LCD cleaner. To remove dirt or salt deposits, use an LCD cleaner, wiping slowly with tissue paper so as to dissolve the dirt or salt. Change paper frequently so the salt or dirt will not scratch the LCD. Do not use solvents such as thinner, acetone or benzene for cleaning.
Ground terminal	Check for tight connection and corrosion.	Clean or replace ground wire as necessary.

## 6.2 Replacement of Fuse

The fuse in the processor unit protects the equipment from reverse polarity of the ship's mains and equipment fault. If the fuse blows, the power cannot be turned on.

Contact your dealer about replacement of the fuse.



Parts Name	Type	Code No.	Remarks
Fuse	FGMB 4A AC125V	000-119-976	Supplied as spare parts

## 6.3 Diagnostics

The NAVpilot-500 has a diagnostic function which checks the Processor unit, Control unit, Heading sensor, Keyboard, LCD and Rudder for proper operation.

To access a diagnostic function, do the following procedure:

1. Press the [MENU] key to show the menu.
2. Rotate the [ENTER] knob to select "TEST".
3. Press the [ENTER] knob to show the test options window.

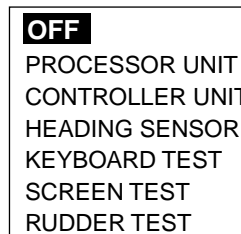

*Test options window*

4. Rotate the [ENTER] knob to select an option.
5. Press the [ENTER] knob.
6. Rotate the [ENTER] knob to display "NO" next to the test item.
7. Press the [ENTER] knob and then rotate the [ENTER] knob to select "YES".
8. Press the [ENTER] knob to start the diagnostic test.
9. Press the [MENU] key to finish.

**PROCESSOR UNIT TEST**

PROCESSOR UNIT	
ROM	OK
No.	6454002-**. **
RAM	OK
EEPROM	OK
RUDDER ANGLE	OK
CLUTCH/BYPASS	OK
REMOTECONTROLLER1	ON 1°
REMOTECONTROLLER2	NOT USED
INPUT VOLTAGE	24.8 V
HEADING SENSOR	--
PORT1	--
PORT2	--
RS232	--

For factory setting

\*\*. \*\* : Program version no.

**CONTROLLER UNIT TEST**

CONTROLLER UNIT	
ROM	OK
No.	6454001-**. **
RAM	OK
COMUNICATION	OK
EEPROM	OK
CONTROLLER ID	

\*\*. \*\* : Program version no.

**HEADING SENSOR TEST**

This test should be done while turning the connected sensor (PG-500) in a circle with 3°/sec. or more. If the sensor is not rotate, this test terminates after one minute with NG result.

HEADING SENSOR	
ROM	OK
No.	6454101-**. **
RAM	OK
EEPROM	OK
SENSOR	OK
RATE SENSOR	OK

\*\*. \*\* : Program vrsion no.

**KEYBOARD TEST**

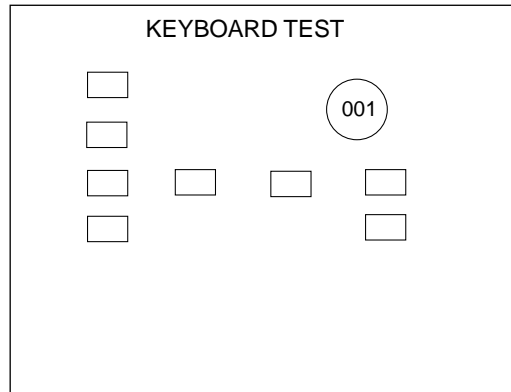

Operate each control on the control unit one by one. A key is functioning properly if its on-screen location lights in black when the key is pressed. For the [ENTER] knob, rotate it to show X-Y position; push it to confirm function.

To escape from the KEYBOARD TEST, press the [POWER/BRILL] key three times.

**SCREEN TEST**

Each press of the [ENTER] knob changes the screen pattern in the sequence shown below.



To escape from the SCREEN TEST, press any key except the [ENTER] knob.

**RUDDER SETUP AND AUTO TEST**

The rudder test checks the following, and then shows the result of the check.

- Drive type
- The presence or absence of bypass/clutch circuit
- Rudder deadband
- Rudder speed

This test should be executed when the boat does not run because of moving the rudder.

When the rudder test is finished, a beep sounds and the message "RUDDER TEST COMPLETED" and the results are shown.

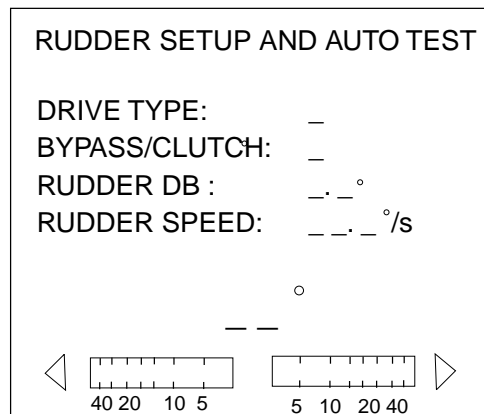

*Rudder test*

DRIVE TYPE: REVERSIBLE or SOLENOID

BYPASS/CLUTCH: EXIST or NON

RUDDER: Shows the rudder deadband

RUDDER SPEED: Rudder speed



### **SYSTEM DATA**

You can confirm the current equipment and drive system status.

1. Press the [MENU] key to show the mode menu.
2. Rotate the [ENTER] knob to select "SYSTEM DATA".
3. Press the [ENTER] knob to show the system data screen.

SYSTEM DATA	
INPUT VOLTAGE:	24.4 V
CONTROLLER ID:	1
DRIVE TYPE:	SOLENOID
BYPASS/CLUTCH:	NON
CONTROLLER TEMP:	43.4 °F
FET TEMP:	24.6 °F
MOTOR DRIVE CUR.:	0.0 A
BYPASS/CLUTCH CUR.:	0.0 A

*System data screen*

## **6.4 Clearing Memories**

Memories can be cleared to restore to default settings.

1. Press the [MENU] key to show the menu.
2. Rotate the [ENTER] knob to select "SYSTEM SETUP".
3. Press the [ENTER] knob to show the System setup menu.
4. Rotate the [ENTER] knob to select MEMORY CLEAR at the bottom of the second page.
5. Press the [ENTER] knob to show the memory clear options window.

<b>ALL CLEAR</b>
DISPLAY CLEAR

*Memory clear options window*

6. Rotate the [ENTER] knob to select ALL CLEAR or DISPLAY CLEAR as appropriate.

ALL CLEAR: Restores all default settings.

DISPLAY CLEAR: Restores settings other than the installation settings, ship's moving feature and compensation for the sensor connected.

**Note:** If you select ALL CLEAR, the all memories and settings stored in the equipment are erased.

7. Press the [ENTER] knob. You are asked if you are sure to clear memory selected
8. Press the [ENTER] knob to clear, or press any key to escape.  
When the [ENTER] knob is pressed, the equipment restarts automatically.

## 6.5 Error Messages

In addition to alarm messages your equipment displays error messages to alert you to probable equipment trouble

### Error messages

<b>Error message</b>	<b>Meaning</b>	<b>Remedy</b>
COMMUNICATION ERROR	Communication between the control unit and the processor unit is interrupted for more than two seconds.	Check the interconnection cable between control unit and processor unit.
INSTANT POWER FAIL IS OCCURRED	Power supply was interrupted for more than two seconds.	Press any key on the control unit.
RUDDER ANGLE ERROR	The rudder angle sent from the rudder reference unit exceeded 55°.	Check the drive motor, bypass valve/clutch.
RUDDER DRIVE ERROR	The rudder did not move more than 1.5° over five seconds after rudder command.	Check the control unit and processor unit connections..
DRIVE UNIT ERROR. PLEASE TURN OFF AND CHECK DRIVE CIRCUIT.	Current of more than 1.5 A was detected on the drive circuit without rudder command.	Check the bypass circuit.
DRIVE UNIT IS OVERLOADED. PLEASE TURN OFF AND CHECK DRIVE CIRCUIT.	Overcurrent was detected.	Check the drive circuit.
DRIVE UNIT IS OVERHEATED.	80°C temperature in drive unit was detected.	Check the drive unit system.
BYPASS/CLUTCH IS OVERLOADED.	Current of more than 1.6 A was detected on the bypass/clutch circuit.	Check the bypass/clutch circuit.
DISCONNECT B/C	No current on the bypass/clutch circuit.	
FU REMOTE CONTROLLER ERROR	Command from the FU remote controller exceeded 55°.	Check the remote controller connection.
MISSING HEADING DATA	The heading data from the heading sensor is missing for 600 ms.	Check the heading sensor and interconnection cable..
HEADING DATA ERROR	Heading data with error flag was detected three times continuously.	Check the heading sensor.
MISSING NAV DATA	The navigational data has been interrupted for more than 15 seconds.	Check the navigator.
DEGRADATION OF NAV DATA QUALITY	The navigation data was incomplete.	Check the navigator settings.
PARAMETER ERROR OF NAV MODE	The navigation data included an error flag.	

Continued on next page

## 6. MAINTENANCE & TROUBLESHOOTING

### Error messages (con't)

INPUT VOLTAGE IS OVER (UNDER) LIMIT	The input power source fluctuated beyond tolerance.	Check ship's mains.
MAGNETIC SENSOR ERROR	The heading data from the heading sensor was wrong.	Check the heading sensor.
RATE SENSOR ERROR		
MAGNETIC DISTORTION ERROR		
NO CALIBRATION	Calibration not yet executed.	Ask your dealer to do the calibration.

# MENU TREE

## STBY mode menu

[MENU] key

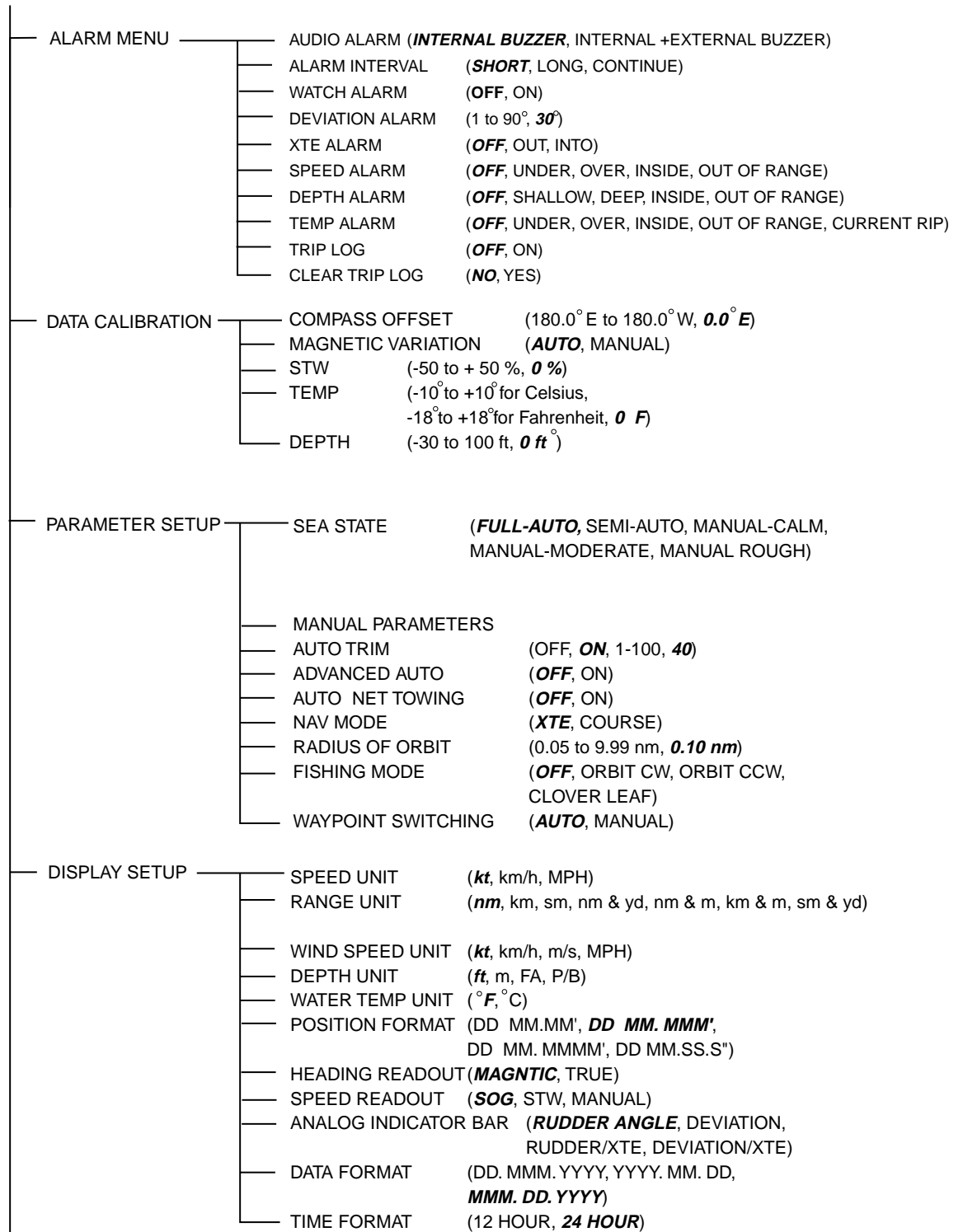

Go to next page.

STBY mode menu (con't)

From the previous page

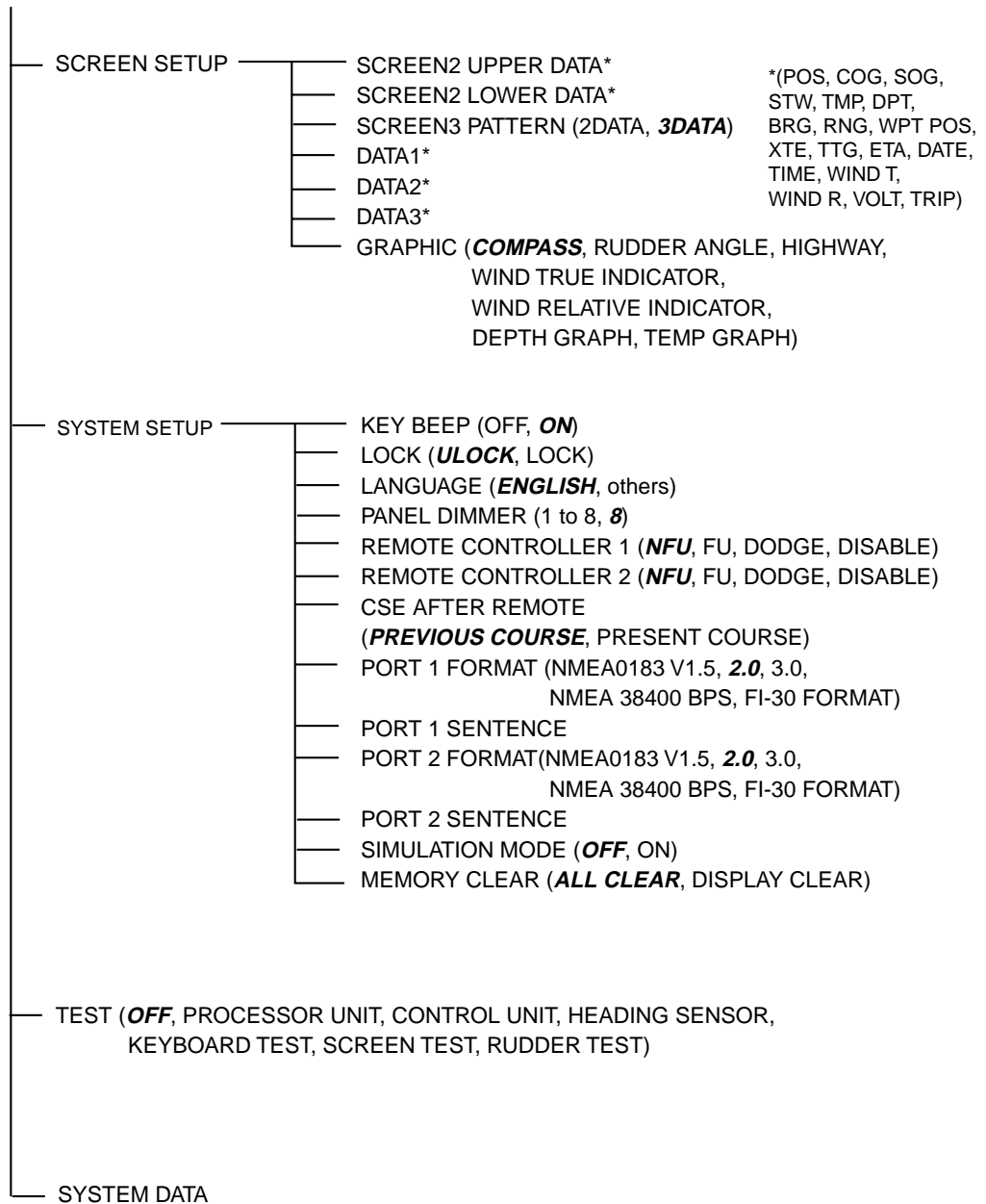

**AUTO mode menu**

[MENU] key

- ALARM MENU            See page MN-1.
- SEA STATE            (**FULL-AUTO**, SEMI-AUTO, MANUAL-CALM,  
MANUAL-MODERATE, MANUAL ROUGH)
- MANUAL PARAMETERS
- AUTO TRIM            (OFF, **ON**, 1-100, **40**)
- ADVANCED AUTO      (**OFF**, ON)
- AUTO NET TOWING    (**OFF**, ON)
- SPEED READOUT      (**SOG**, STW, MANUAL)
- RADIUS OF ORBIT     (0.05 to 9.99 nm, **0.10 nm**)
- SYSTEM DATA

**NAV mode menu**

[MENU] key

- ALARM MENU            See page MN-1.
- SEA STATE            (**FULL-AUTO**, SEMI-AUTO, MANUAL-CALM,  
MANUAL-MODERATE, MANUAL ROUGH)
- MANUAL PARAMETER
- AUTO TRIM            (OFF, **ON**, 1-100, **40**)
- WAYPOINT SWITCHING (**AUTO**, MANUAL)
- NAV MODE             (**XTE**, COURSE)
- FISHING MODE        (**OFF**, ORBIT CW, ORBIT CCW, CLOVER LEAF)
- SPEED READOUT      (**SOG**, STW, MANUAL)
- RADIUS OF ORBIT     (0.05 to 9.99 nm, **0.10 nm**)
- SYSTEM DATA

# SPECIFICATIONS OF AUTOPILOT

## NAVpilot-500

### 1 CONTROL UNIT

- |     |             |  |
|-----|-------------|--|
| 1.1 | Display     | Monochrome LCD, 83 (W) x 83 (H) mm, 160x160 dots |
| 1.2 | Backlight   | Adjustable in 8 steps                            |
| 1.3 | Contrast    | 16 steps   |
| 1.4 | Useable Set | 6 sets   |

### 2 PROCESSOR UNIT

- |     |                         |  |
|-----|-------------------------|--|
| 2.1 | Rudder Mode             | Manual, Auto, Dodge, Remote, Advanced Auto*, Navigation*                       |
| 2.2 | Weather Adjustment      | AUTO/SEMI-AUTO/CALM/MODERATE/ROUGH   |
| 2.3 | Rudder Angle Ratio      | AUTO/0-9   |
| 2.4 | Rudder Angle Equivalent | AUTO/0-9   |
| 2.5 | Rudder Angle Settings   | 45° max.   |
| 2.6 | Alarm                   | Bearing deviation, Out of course*, Watch, Ship's speed*,<br>Water temperature* |
- \*: Navigation data required

### 3 INTERFACE

- |     |                       |   |
|-----|-----------------------|---|
| 3.1 | Ports                 | Navigation data in/out (NMEA): 1, Output (NMEA): 1<br>Input (NMEA): 1, I/O for Heading Sensor (NMEA): 1   |
| 3.2 | Input Sentences       | IEC 61162-2,<br>NMEA 0183 1.5/2.0/3.0   |
|     | Command Bearing       | APA, APB, BOD/XTE, RMB  |
|     | Ship's Location (L/L) | GGA, RMC, RMA, GLL, GNS   |
|     | Ship's Location (LOP) | GLC, GTD, RMA   |
|     | SOG/COG               | VTG, RMC, RMA   |
|     | STW                   | VHW   |
|     | Heading (HDG)         | HDT, HDG, HDM   |
|     | Destination           | RMB, WPL  |
|     | Bearing/distance      | RMB, BWC, BWR   |
|     | Time                  | RMC, ZDA  |
|     | Arrival Alarm         | AAM, RMB  |
|     | Cross Track Error     | APB, XTE, RMB   |
|     | Water Depth           | DPT, DBT  |
|     | Water Temperature     | MTW   |
|     | Wind Speed/Bearing    | VPW, MWD, MWV   |
| 3.3 | Output Sentences      | IEC 61162-2, NMEA 0183 1.5/2.0/3.0<br>AAM, ALR, ASD, BWC, BWR, DBT, DPT, GGA, GLC, GLL, GTD,<br>GNS, HDG, HDT, HSC, MTW, MWV, RMA, RMB, RMC, RSA, VBW,<br>VHW, VTG, WPL, XTE, ZDA |

3.4 I/O Control RS-232C (NMEA)

## 5 POWER SUPPLY

3.1 Processor Unit 12-24 VDC: 3-2 A (Control Unit: 6 sets)

## 6 ENVIRONMENTAL CONDITIONS

4.1 Ambient Temperature -10°C to +55°C

4.2 Relative Humidity 95% at 40°C

6.3 Waterproof

Processor unit: IPX2

Control unit/ Remote controller/ Rudder reference unit: IPX5

6.4 Vibration IEC 60945

## 7 COLOR

5.1 Processor Unit N3.0

5.2 Control Unit N3.0

5.3 Remote Controller N3.0 (FAP-5552/6232), N1.5 (FAP-6212/6222)

5.4 Rudder Reference Unit N1.0

5.5 Junction Box N3.0



# INDEX

---

- A
  - ADVANCED AUTO mode..... 3-3
  - ALARM INTERVAL ..... 5-2
  - AUDIO ALARM ..... 5-2
  - AUTO mode ..... 3-2
  - AUTO TRIM ..... 4-8
  - ANALOG INDICATOR BAR ..... 2-8, 4-11
- B
  - Brilliance ..... 2-3
- C
  - CLOVER LEAF ..... 3-8, 3-10
  - COMPASS OFFSET ..... 4-2
  - Contrast ..... 2-3
  - COUNTER RUDDER..... 4-7
  - COURSE AFTER REMOTE ..... 3-15
- D
  - Data Display ..... 2-7
  - DATE FORMAT ..... 4-11
  - DEVIATION LEVEL..... 4-4
  - DEPTH UNIT ..... 4-11
  - Deviation alarm ..... 5-3
  - DISPLAY SETUP menu ..... 4-10
  - Distance alarm ..... 5-6
  - DODGE mode..... 3-17
- E
  - ENTER knob ..... 2-1
- G
  - Graphic Display..... 2-7
- H
  - HEADING READOUT ..... 4-11
- K
  - KEY BEEP ..... 4-12
- L
  - LANGUAGE ..... 4-13
  - LOCK ..... 4-13
- M
  - MAGNETIC VARIATION-..... 4-2
- N
  - NAV mode ..... 3-5
  - NET TOWING ..... 4-9
  - Normal Display..... 2-4
- O
  - ORBIT ..... 3-9, 3-10
- P
  - PANEL DIMMER ..... 4-13
  - Parameter ..... 4-3
  - POSITION FORMAT ..... 4-11
- R
  - Range unit..... 4-11
  - REMOTE mode..... 3-11
  - RUDDER GAIN..... 4-6
- S
  - Sailing method ..... 3-6
  - SEA STATE ..... 4-3
  - SIMULATION MODE ..... 4-14
  - Speed alarm ..... 5-4
  - SPEED UNIT..... 4-11
  - SPEED READOUT ..... 4-11
  - STBY mode..... 3-1
  - SYSTEM SETUP menu ..... 4-12
- T
  - Temperature alarm ..... 5-6
  - Tests ..... 6-2
  - TIME FORMAT..... 4-11
  - TLL ..... 3-10
- W
  - Waypoint ..... 3-5, 3-6, 3-7, 3-8
  - WATCH ALARM ..... 5-3
  - WATER TEMP UNIT ..... 4-11
  - WEATHER ..... 4-6
  - WIND SPPED UNIT ..... 4-11
- X
  - XTE alarm ..... 5-3

## Free Manuals Download Website

<http://myh66.com>

<http://usermanuals.us>

<http://www.somanuals.com>

<http://www.4manuals.cc>

<http://www.manual-lib.com>

<http://www.404manual.com>

<http://www.luxmanual.com>

<http://aubethermostatmanual.com>

Golf course search by state

<http://golfingnear.com>

Email search by domain

<http://emailbydomain.com>

Auto manuals search

<http://auto.somanuals.com>

TV manuals search

<http://tv.somanuals.com>