

## ThermoLazer™ Pavement Marking System

313879B

- For professional application of thermoplastic traffic marking compound materials (reflective beads applied simultaneously with screeding) -
- For outdoor use only (not to be operated in rain or damp conditions) -

**Model No. 258699 North America - Includes 257500 and 4 in. (10 cm) SmartDie™ Screed Box**  
**Model No. 257500 International (SmartDie™ Screed Box not included)**

Fuel: LP Gas (Propane Vapor)

Burner capacities (max total): 138,000 BTU/hr. (40.44 kW) [38,000 BTU/hr. (7.03 kW) without torch]

Material capacity (max): 300 lb (136 kg)



### IMPORTANT SAFETY INSTRUCTIONS

Read all warnings and instructions in this manual. Save these instructions.

#### Related Manuals

**Operation** 313787  
**Parts** 313880

#### For use with the following SmartDie™ Screed Box:

Part	Description
256736	4 in. (10 cm) Screed Box
257469	5 in. (12 cm) Screed Box
256737	6 in. (15 cm) Screed Box
257470	7 in. (18 cm) Screed Box
256738	8 in. (20 cm) Screed Box
257471	9 in. (22.5 cm) Screed Box
257472	10 in. (26 cm) Screed Box
256739	12 in. (30 cm) Screed Box
256799	Double Line 4-4-4 in. (10-10-10 cm) Screed Box
24B729	Double Line 4-3-4 in. (10-8-10 cm) Screed Box

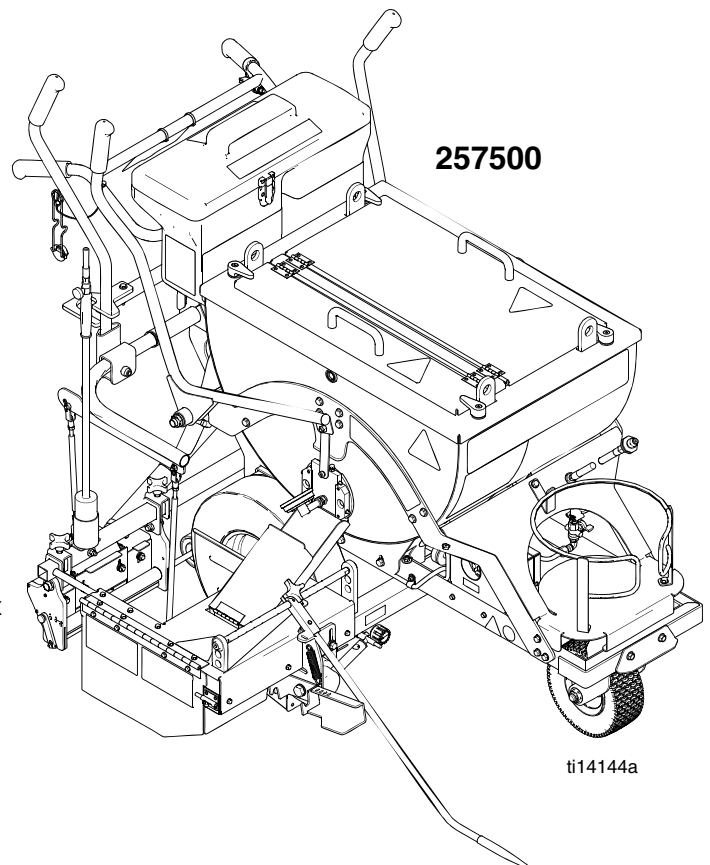





PROVEN QUALITY. LEADING TECHNOLOGY.



# Table of Contents

Table of Contents .....	2	Adjust Kettle Main Burners Flame .....	12
Warnings .....	3	Cleaning Kettle Main Burner Gas Lines .....	13
Kettle Gas Safety Valve, Kettle Temperature Control, and Kettle Thermopile Diagnosis .....	5	Cleaning Kettle Pilot Burner Gas Lines .....	13
Kettle Temperature Control Calibration .....	6	Replacing Screed Box Spring .....	14
Temperature Control Replacement .....	6	Securing Bead Dispenser Wheel .....	15
Thermometer Replacement .....	6	Linkage Rod Adjustment .....	15
Kettle Thermometer Calibration .....	7	Screed Box/Bead Dispenser Box Actuator .....	15
Adjust Kettle Pilot Ignitor Electrode Gap .....	7	Adjusting Screed Box Pivot Arm .....	16
Thermopile Replacement .....	8	Troubleshooting .....	17
Adjust Gas Pressure to Kettle Burners .....	11	Technical Data .....	23
Adjust Kettle Pilot Burner Flame .....	12	Graco Standard Warranty .....	24
		Graco Information .....	24

# Warnings

The following are general warnings related to the safe setup, use, grounding, maintenance and repair of this equipment. In the text of this manual, the exclamation point symbol alerts you to a warning and the hazard symbol refers to specific risks. Refer back to these General Warnings pages. Additional procedure-specific warnings will be included where applicable.

	<b>Warnings</b>
	<p><b>FIRE AND EXPLOSION HAZARD</b> Flammable fumes and liquids, such as propane gas, gasoline and combustible fuel, in <b>work area</b> can ignite or explode. To help prevent fire and explosion:</p> <ul style="list-style-type: none"> <li>• Do not use equipment unless fully trained and qualified.</li> <li>• Do not allow open containers of flammables within 25 ft (7.6 m) of equipment. Do not operate equipment within 10 ft (3 m) of any structure, combustible material, or other gas cylinders.</li> <li>• Shut off all burners when adding fuel to equipment.</li> <li>• Close the tank shut-off valve immediately if you smell propane gas; extinguish all open flames. If gas odor continues, keep away from equipment and immediately call the fire department.</li> <li>• Follow lighting instructions for the burner and torch.</li> <li>• Do not heat thermoplastic traffic marking compound material above 450° F (232° C)</li> <li>• Fire extinguisher equipment shall be present and working.</li> <li>• Keep work area free of debris, including solvent, rags and gasoline.</li> </ul>
	<p><b>EQUIPMENT MISUSE HAZARD</b> Misuse can cause death or serious injury.</p> <ul style="list-style-type: none"> <li>• Do not leave equipment unattended.</li> <li>• Keep children and animals away from work area.</li> <li>• Do not exceed the maximum working pressure or temperature rating of the lowest rated system component. See <b>Technical Data</b> in all equipment manuals.</li> <li>• Check equipment daily. Repair or replace worn or damaged parts immediately with genuine manufacturer's replacement parts only.</li> <li>• Do not alter or modify equipment.</li> <li>• Use equipment only for its intended purpose. Call your Graco distributor for information.</li> <li>• Do not fill material beyond maximum capacity.</li> <li>• Route gas lines, hoses, wires and cables away from traffic areas, sharp edges, moving parts, and hot surfaces.</li> <li>• Do not kink or overbend gas lines.</li> <li>• Do not override or defeat safety devices.</li> <li>• Do not operate the unit when fatigued or under the influence of drugs or alcohol.</li> </ul>
	<p><b>BURN HAZARD</b> Equipment surfaces and fluid that is heated can become very hot during operation. To avoid severe burns:</p> <ul style="list-style-type: none"> <li>• Do not touch hot fluid or equipment.</li> <li>• Wait until equipment and material has cooled completely.</li> </ul>
	<p><b>CARBON MONOXIDE HAZARD</b> Exhaust contains poisonous carbon monoxide, which is colorless and odorless. Breathing carbon monoxide can cause death. Do not operate in an enclosed area.</p>

<b>Warnings</b>	
	<p><b>TOXIC FLUID OR FUMES HAZARD</b></p> <p>Toxic fluids or fumes can cause serious injury or death if splashed in the eyes or on skin, inhaled, or swallowed.</p> <ul style="list-style-type: none"> <li>• Read MSDS to know the specific hazards of the materials you are using.</li> </ul>
	<p><b>PERSONAL PROTECTIVE EQUIPMENT</b></p> <p>You must wear appropriate protective equipment when operating, servicing, or when in the operating area of the equipment to help protect you from serious injury, including eye injury, inhalation of toxic fumes, burns, and hearing loss. This equipment includes but is not limited to:</p> <ul style="list-style-type: none"> <li>• Clothing and respirator as recommended by the fluid, material, and solvent manufacturer.</li> <li>• Gloves, shoes, overalls, face shield, hat, etc. rated for elevated temperatures of at least 500° F (260° C).</li> </ul>

# Kettle Gas Safety Valve, Kettle Temperature Control, and Kettle Thermopile Diagnosis

The gas safety valve, temperature control and thermopile can be checked by using a millivolt meter. Before checking, make certain all electrical connections are clean and tight.

Connect millivolt meter to appropriate terminals (see **Terminal Connections**).

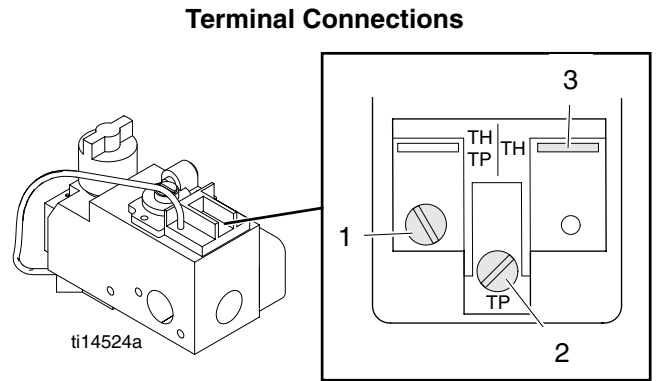

Step	Part(s) to Be Checked	Terminal Connections	Status of Temperature Control Contacts	Desired Meter Reading	Diagnosis
1	Gas safety valve	2 and 3	Closed	Greater than 100 mV	If mV reading > 100 mV and the automatic valve (main burners) does not come on, replace the gas safety valve. If mV reading < 100mV, proceed with diagnostic steps 2 and 3.
2	Temperature control	1 and 2	Closed	Less than 80 mV	<p>If reading &gt; 80 mV:</p> <ul style="list-style-type: none"> <li>Clean and tighten electrical connections at temperature control and gas safety valve.</li> <li>Check valve to make sure wires are in good condition. Replace as required.</li> <li>Rapidly change temperature setting on temperature control to see if cycling cleans the contacts.</li> </ul> <p>If the preceding fails to give mV reading &lt; 80 mV, replace temperature control.</p>
3	Gas safety valve magnet and thermopile	1 and 2	Open	Greater than 325 mV	<p>If mV reading &lt; 325 mV:</p> <ul style="list-style-type: none"> <li>Clean and tighten all electrical connections.</li> <li>Adjust pilot burner to increase millivolt output (see page 11).</li> </ul> <p>If the preceding fails to give mV reading &gt; 325 mV, replace thermopile.</p> <p>Check valve magnet after obtaining correct mV output for thermopile:</p> <ul style="list-style-type: none"> <li>Ignite pilot burner only and allow the mV reading to stabilize.</li> <li>Shut pilot burner (turn gas safety valve knob OFF).</li> </ul> <p>Note the mV reading where magnet drops out.</p> <p>If magnet unlocks at mV reading &lt; 120 mV, the magnet is OK. NOTE: When magnet unlocks a click can be heard and mV reading may fluctuate slightly.</p>

# Kettle Temperature Control Calibration

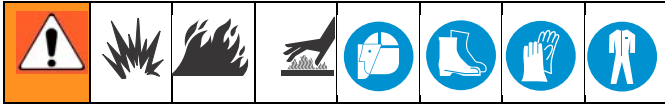

## To Check Kettle Temperature Control Calibration:

1. Move ThermoLazer™ to an area with no wind.
2. Turn temperature control to 400° F (204° C).
3. Agitate material for 4 to 5 minutes.
4. After control has reached steady state temperature and burners do not cycle more than once per minute, insert remote calibrated temperature probe in material and directly adjacent kettle temperature control probe.
5. Compare temperature of remote calibrated temperature probe to temperature setting on temperature control.

6. If the temperature control setting is lower than the remote calibrated temperature setting on temperature probe, turn adjusting screw clockwise. Every 1/4 in. turn will change temperature 35° F (19.4° C).

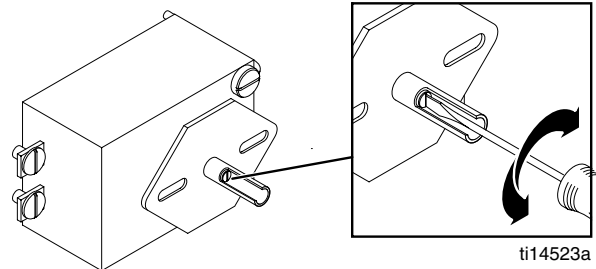

7. If the temperature control setting is higher than the remote calibrated temperature probe, turn adjusting screw counterclockwise--every 1/4 in. turn will change temperature 35° F (19.4° C).
8. Recheck calibration by turning temperature control to 410° F (210° C) and repeat steps 3-7.

# Temperature Control Replacement

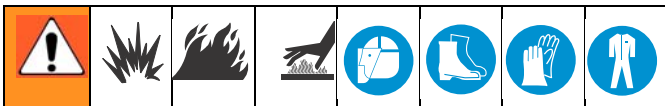

When replacing temperature control, keep in mind that the temperature probe is an integral part of the assembly. Do not make any sharp bends in the capillary tubing. Bends should be 0.25 in. (0.64 cm) in radius or greater.

Be sure to seal capillary tubing with high temperature mortar at kettle outlet.

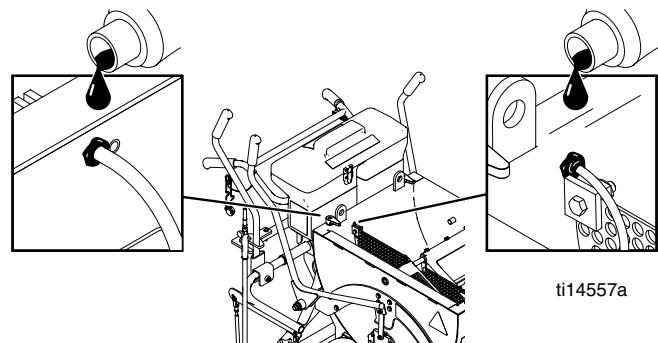

# Thermometer Replacement

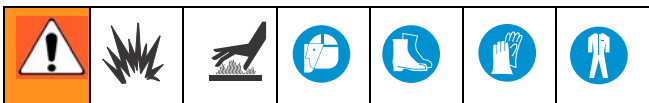

Thermometer can not be removed from ThermoLazer™ without damaging thermometer probe. If probe end is frozen in material, heat material and remove until material level is lower than thermometer probe.

# Kettle Thermometer Calibration

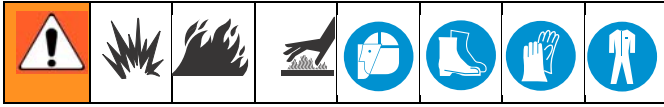

## To Check Kettle Thermometer Calibration:

1. Move ThermoLazer™ to an area with no wind.
2. Turn temperature control to 400° F (204° C).
3. Agitate material for 4 to 5 minutes.
4. After control has reached steady state temperature and burners do not cycle more than once per minute, insert remote calibrated temperature probe in material and directly adjacent kettle temperature control probe.
5. Compare temperature of remote calibrated temperature probe to thermometer.

6. If kettle thermometer is lower than the remote calibrated temperature probe, turn adjusting screw counterclockwise.

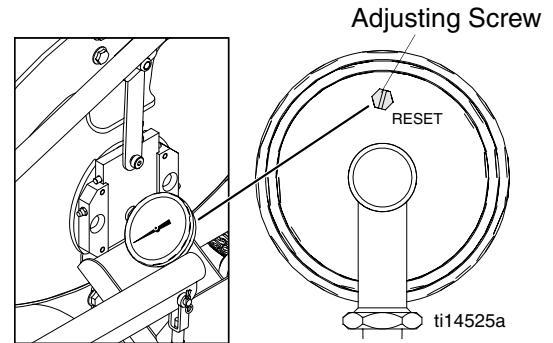

7. If the kettle thermometer is higher than the remote calibrated temperature probe, turn adjusting screw clockwise.

## Adjust Kettle Pilot Ignitor Electrode Gap

1. Loosen screw (231).
2. Rotate ignitor electrode (7) until gap of .17 to .20 in. (.43 to .51 cm) is achieved.
3. Retighten screw (231).

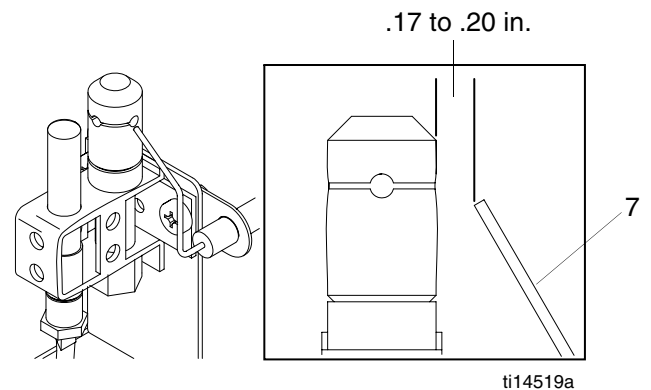

# Thermopile Replacement

## Removal

1. Shut off gas valve on LP-tank and disconnect hose.

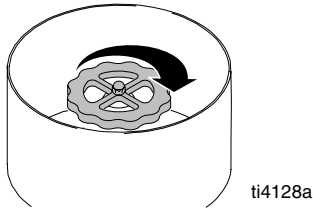

2. Remove gas safety valve enclosure back cover.

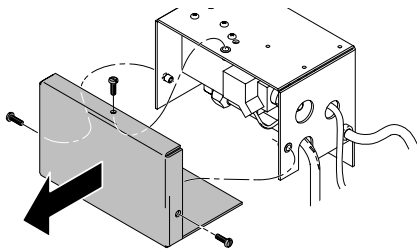

3. Remove cover (252) from gas safety valve enclosure (28).

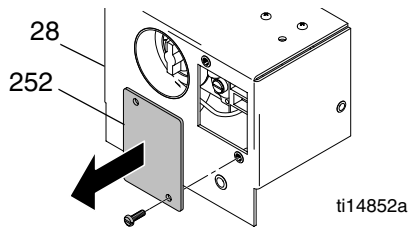

4. Disconnect thermopile wires from gas safety valve (13).

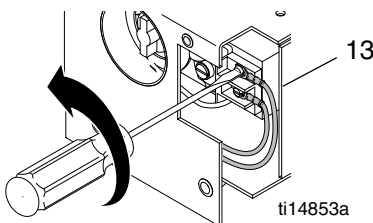

5. Remove wire grommet (209) from gas safety valve enclosure (28).

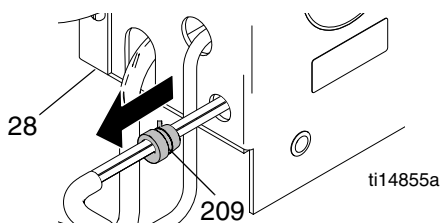

6. Pull thermopile wire out of gas safety valve enclosure (28).

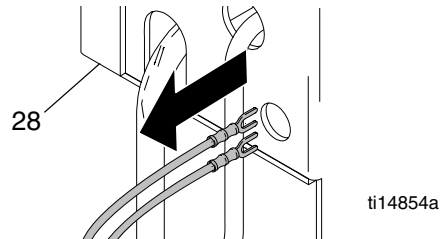

7. Cut wire tie.

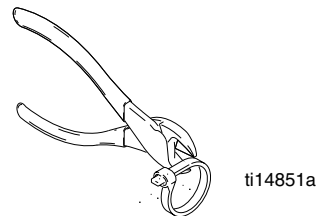

8. Disconnect gas pilot line (76) at gas pilot coupling (171).

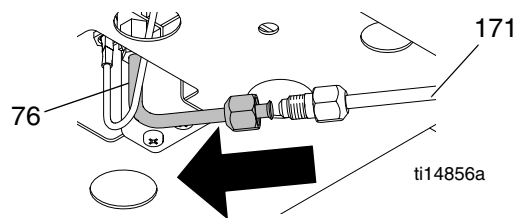

9. Remove gas pilot mounting plate (18).

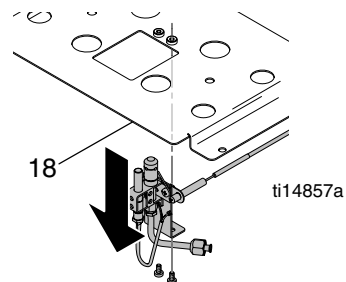

10. Remove thermopile (7).

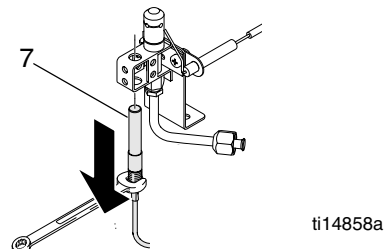



## Installation

1. Replace thermopile (7).

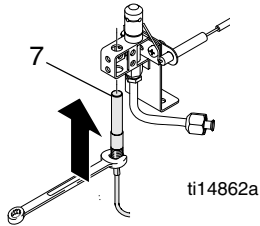

2. Replace gas pilot mounting plate (18).

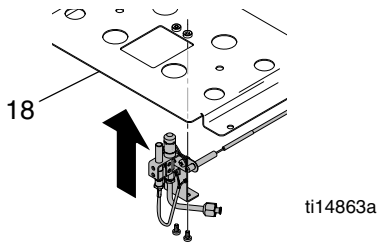

3. Connect gas pilot line (76) at gas pilot coupling (171).

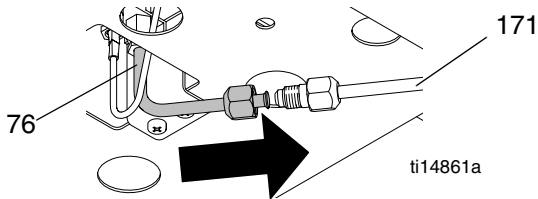

4. Guide thermopile wire into gas safety valve enclosure (28).

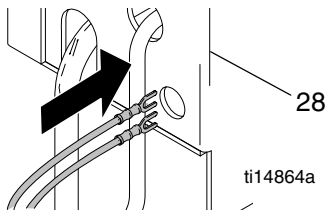

5. Zip-tie wires together.

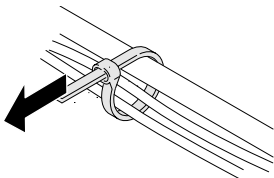

6. Replace wire grommet (209) on gas safety valve enclosure (28).

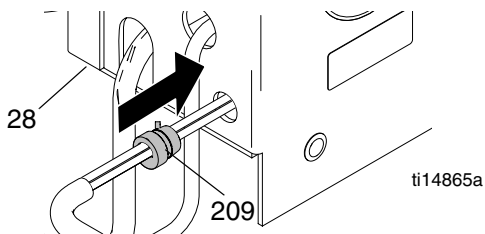

7. Connect thermopile wires to gas safety valve (13). See **Parts** manual 313880 for additional details.

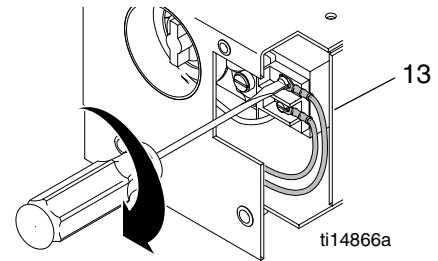

8. Replace cover (252) on gas safety valve enclosure (28).

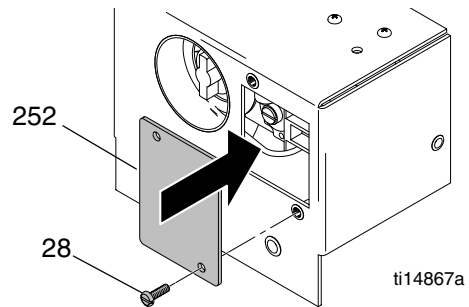

9. Replace gas safety enclosure back cover.

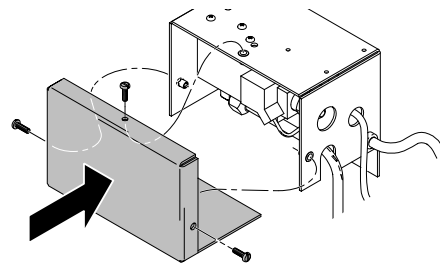

10. Reconnect hose and turn LP-gas tank valve ON.

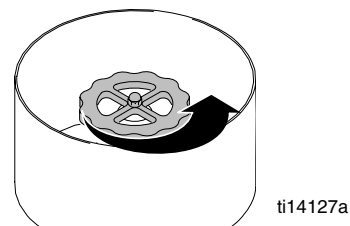

# Adjust Gas Pressure to Kettle Burners

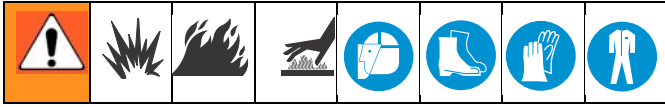

1. Shut off kettle gas safety valve (CC).
2. Turn kettle temperature control knob (AA) to 0 ("OFF").
3. Remove kettle gas safety valve 1/8-27 NPT pipe plug.
4. Screw 0 to 30 in. w.c. (0 to 7.47 cb) calibrated gas pressure gauge or manometer into kettle gas safety valve outlet.
5. Ignite kettle gas pilot burner.
6. Turn kettle gas safety knob (CC) to ON.
7. Turn kettle temperature control to 250° F (121° C).
8. Record gas pressure at kettle gas safety valve outlet. Gas pressure should read 11 in. w.c. (2.74 cb).
9. Remove adjusting screw cap.
10. Turn adjusting screw (148) clockwise to increase gas pressure (counterclockwise to decrease gas pressure).
11. Install adjusting screw cap.
12. Turn kettle temperature control knob (AA) to 0 ("OFF").
13. Shut off kettle gas safety valve (CC).
14. Remove gas pressure measuring device.
15. Add LP-gas pipe sealant to 1/8-27 NPT pipe plug (156) and install in kettle gas safety valve.

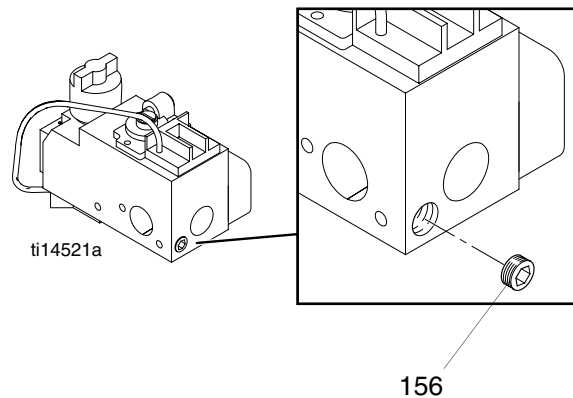
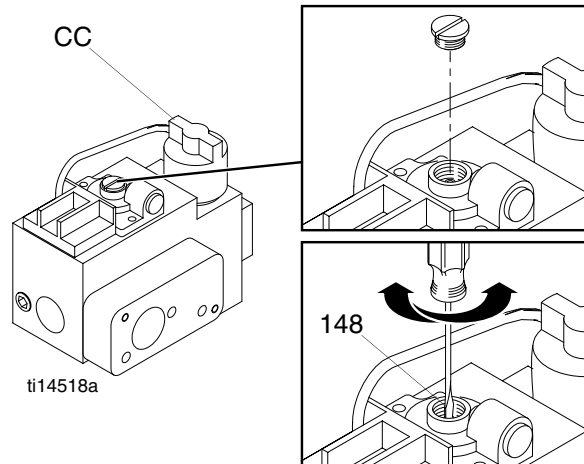

## Adjust Kettle Pilot Burner Flame

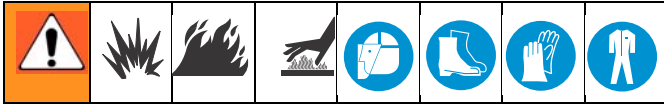

1. Ignite kettle gas pilot burner.
2. Record pilot burner flame height and color. Flame should be 2 to 3 in. (5 to 7 cm) high and blue-orange in color.
3. Remove flame adjusting screw cap.
4. Turn adjusting screw clockwise to decrease flame height (counterclockwise to increase flame height).
5. Install flame adjusting screw cap.

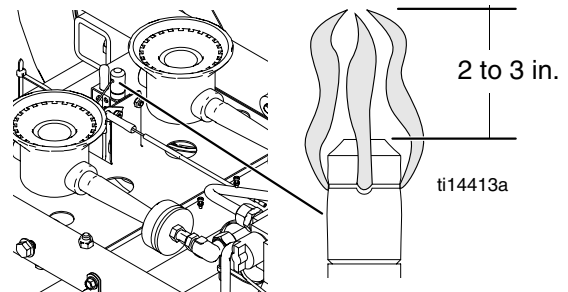
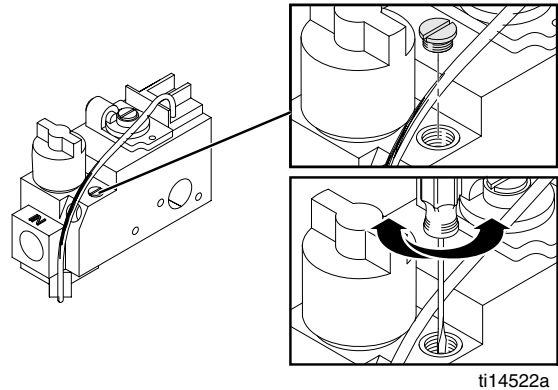

## Adjust Kettle Main Burners Flame

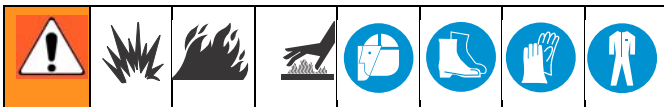

1. Ignite kettle gas pilot burner.
2. Turn kettle gas safety valve (CC) to ON.
3. Turn kettle temperature control knob (AA) to 250° F (121° C).
4. Record pilot burner flame height and color. Flame should be 1 to 2 in. (3 to 5 cm) high and blue-orange in color.
5. Record burner venturi gap. Gap should be .17 to .20 in. (4 to 5 mm).
6. Loosen air shutter jam nut and adjust air shutter to obtain correct gap.
7. Lock air shutter jam nut. Use thread sealant for a more secure locking.

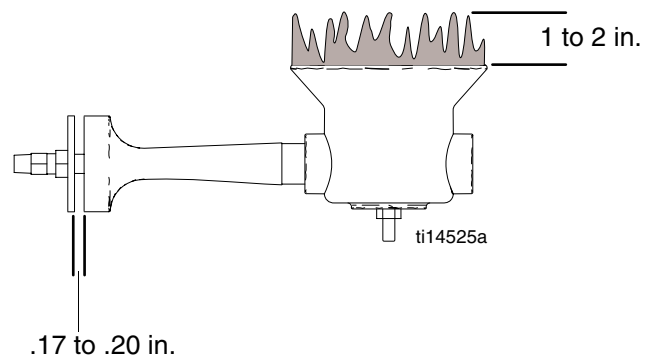

## Cleaning Kettle Main Burner Gas Lines

1. Disconnect gas tubing line (49) from gas tube fitting tee (165).
2. Force air into gas tubing line (49). Insert rubber hose over gas tubing tee and force air into tubing at 30 psi (2.1 bar).
3. Reconnect gas tubing line (49) to gas tube fitting tee (165).

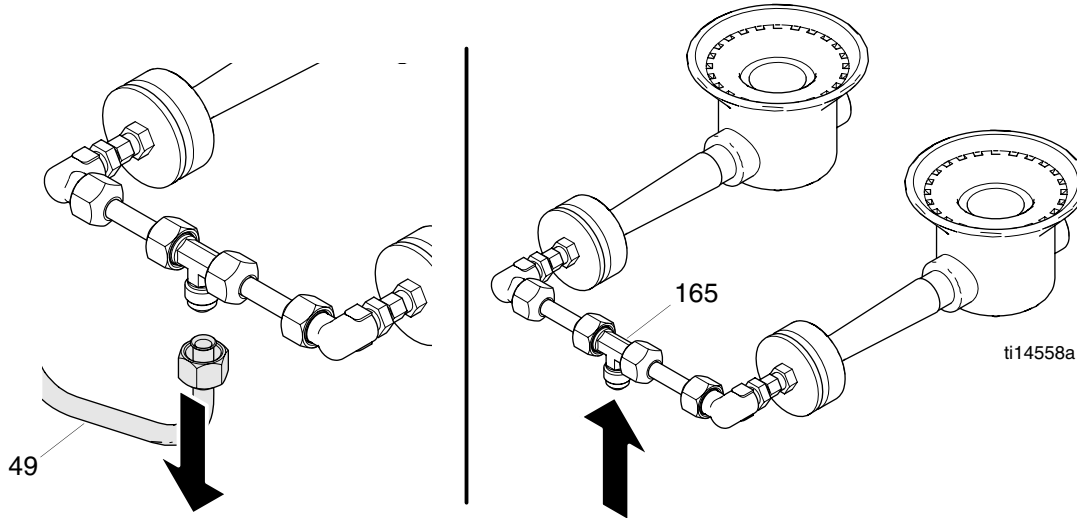

## Cleaning Kettle Pilot Burner Gas Lines

1. Disconnect gas tubing line (186) from gas tubing line (118).
2. Force air into gas tubing line (118). Insert rubber hose over gas tubing tee and force air at 30 psi (2.1 bar).
3. Reconnect gas tubing line (186) to gas tubing tee (118).

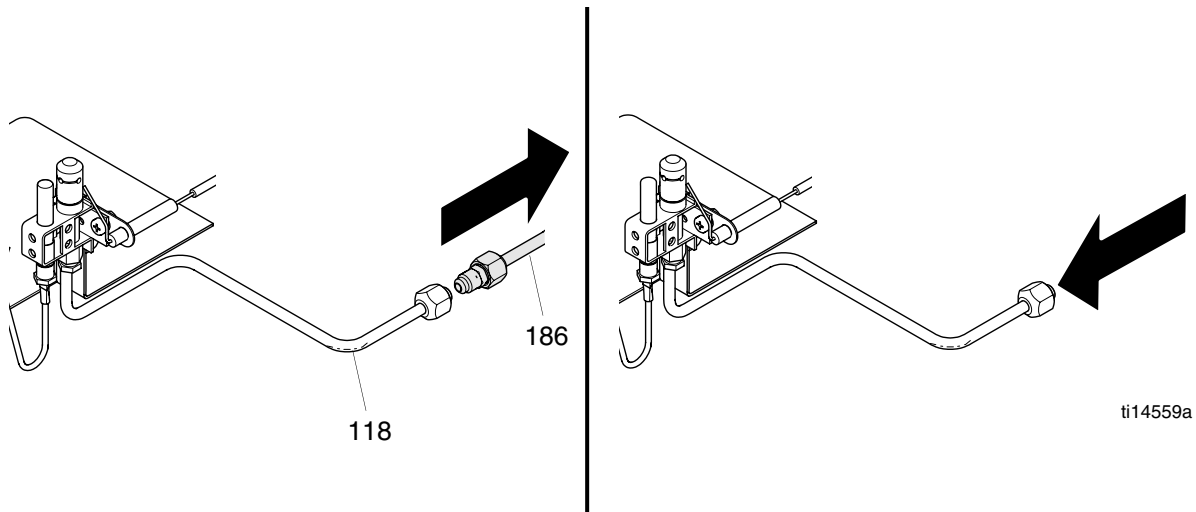

# Replacing Screed Box Spring

1. Position replacement spring as shown below and slide into spring guard.

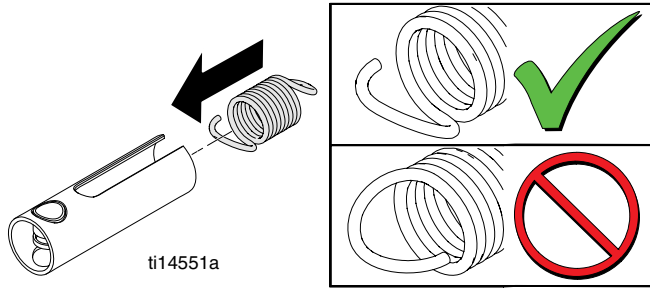

2. Push spring up through guard and loop end around guard pin until spring sits in groove.

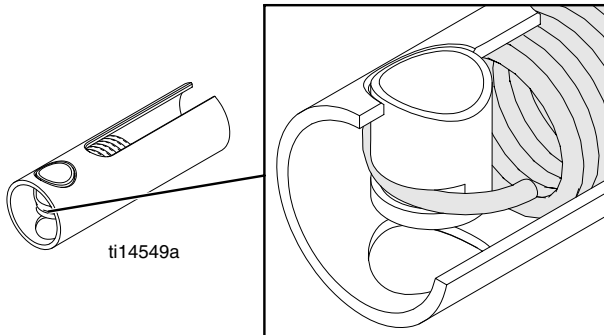

3. Set screed box on its side.

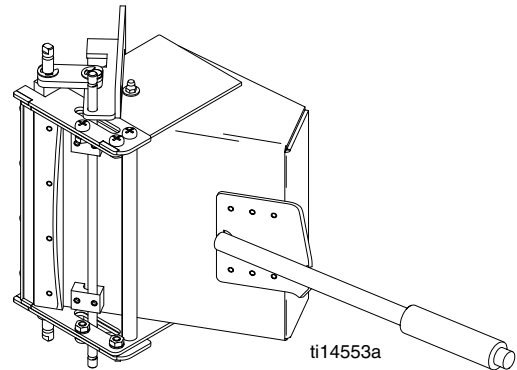

4. Loop open end of spring and guard over first pin on screed box. Then push spring guard up and over second pin on screed box.

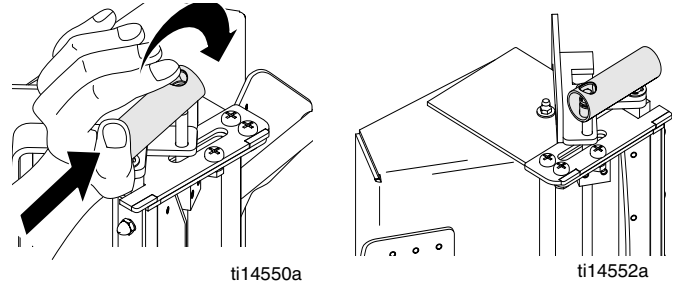

# Securing Bead Dispenser Wheel

To properly dispense beads, drive wheel (27) must be in direct contact with tire (89). If drive wheel (27) becomes loose and/or starts to slip, use allen wrench to tighten set screw (211).

**NOTE:** To ensure proper contact between drive wheel (27) and tire (89), make sure air pressure is always at 60 psi (4.14 bar).

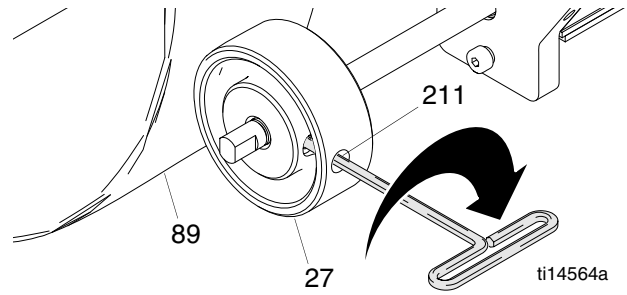

## Linkage Rod Adjustment

Adjustments can be made to linkage rods by removing clevis cotter hairpin (268), clevis (179) pin, loosening nuts (128), and then turning clevis as required to lengthen or shorten rod connectors.

To ensure proper application of beads and thermoplastic, make sure screed box linkage rod (182) measures 16.875 in. (42.8 cm). Be sure to measure where nut (128) meets clevis (179) when checking for proper linkage rod length.

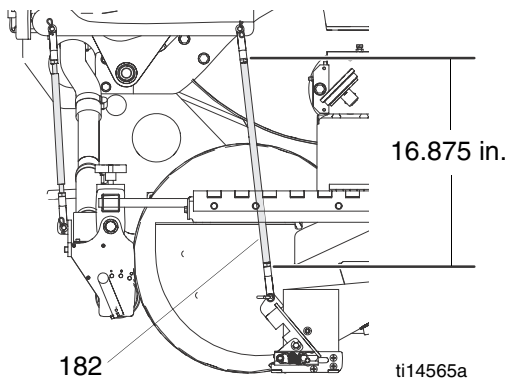

2. If the wheel does not cause the ThermoLazer tire to rotate both forward and backwards, loosen nuts (128), clevis cotter hair pin, clevis pin, and rotate the clevis (179) one turn counterclockwise.

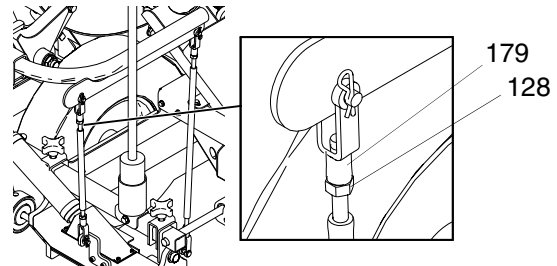

3. Reconnect clevis to deployment bar and again rotate bead box wheel to see if adjustments cause ThermoLazer to move forward and backwards.
4. Continue to rotate clevis 1/2 turn counterclockwise until rotating bead box wheel causes ThermoLazer to move forward and backwards.

Adjust the bead box linkage rod (181) so bead box drive is touching ThermoLazer tire when screed box is in down (but not open) position. A slight downward force on the bead box linkage should be required when inserting the clevis pin through the clevis deployment bar.

1. With screed box in down (but not open) position, rotate the bead box wheel by hand.

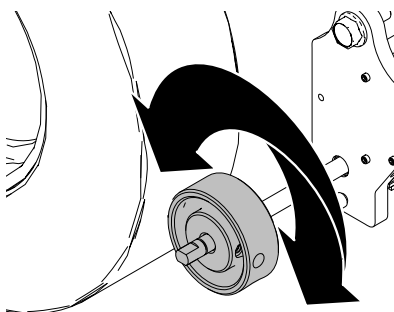

## Screed Box/Bead Dispenser Box Actuator

If the screed box/bead dispenser box actuator does not remain in the “down and locked” position, adjust the 3/4-16 lock nut by turning clockwise 1/4 to 1/2 turn or until the actuator does not freely rotate.

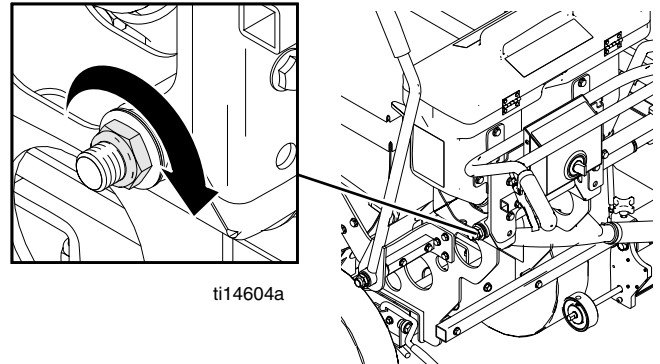

ti14604a

## Adjusting Screed Box Pivot Arm

If the SmartDie™ screed box jumps up when setting the box in the down-and-locked position, check linkage rod lengths (see page 14).

If the SmartDie™ screed box continues to jump up after adjusting linkage rods, move the screed box pivot arm spring to the next hole.

1. Unhook top of box pivot arm spring.

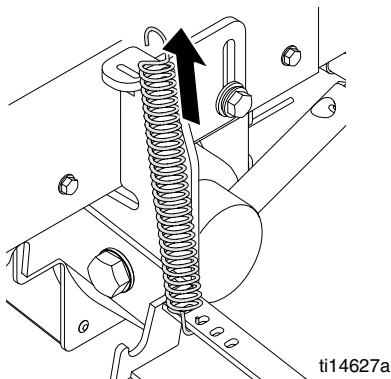

ti14627a

2. Unhook bottom of box pivot arm spring.

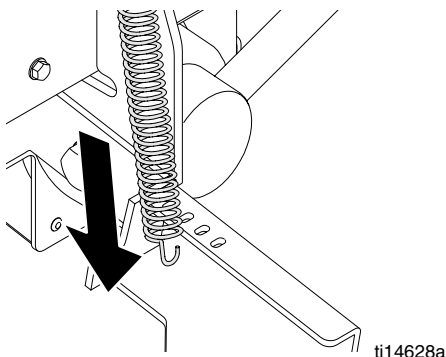

ti14628a

3. Move bottom of box pivot arm spring to desired hole and reconnect. Moving the spring in will decrease tension, while moving the spring out will increase tension.

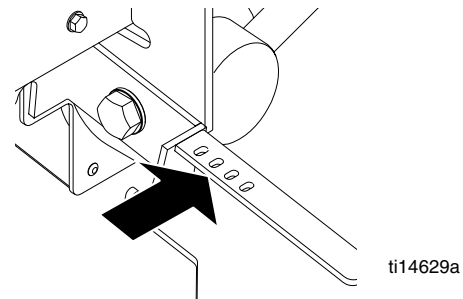

ti14629a

4. Reconnect top of box pivot arm spring.

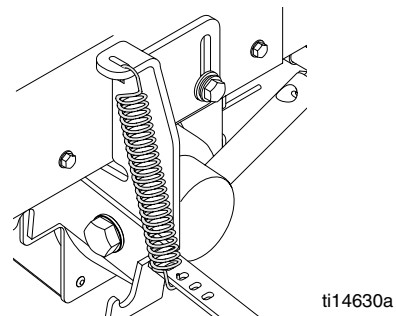

ti14630a

Repeat moving pivot arm spring until SmartDie™ screed box stops jumping up when setting box in the down-and-locked position.

If moving pivot arm spring does not stop the SmartDie™ screed box from jumping up when setting box in down-and-locked position, replace pivot arm spring.

# Troubleshooting

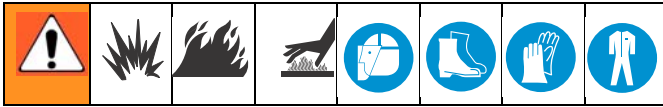

Problem	Cause	Solution
Kettle pilot burner does not ignite or does not remain ignited	Low or empty LP-gas tank	Replace with full tank.
	Gas supply hose not connected to tank	Connect gas supply hose.
	LP-gas tank shut-off valve closed	Open LP-gas tank shut-off valve.
	Manual gas shut-off valve closed	Open manual gas shut-off valve.
	Gas lines leaking or disconnected	Check for gas leaks. Connect and tighten fittings.
	Kettle gas safety valve knob not in correct position	Turn knob to "PILOT" position and fully push in (see Operation manual).
	Not providing adequate time for thermopile to heat up	See Operation manual.
	Kettle pilot igniter has weak battery	Replace part (see Parts manual).
	Kettle pilot electrode gap incorrect	Adjust gap (see page 7).
	Incorrect flame length and/or gas pressure	Adjust flame and pressure (see Repair manual).
	Strong wind blowing flame out	Move ThermoLazer™ out of strong winds. Make sure burner view ports are closed.
	Burner and/or gas lines plugged	Unplug holes and lines. Isolate all gas regulators if clearing line with forced air (see page 5).
	Kettle gas safety valve not functioning correctly	Replace part if it fails diagnostic test (see page 5).
	Thermopile not functioning correctly	Replace part if it fails diagnostic test (see page 8).
	Kettle pilot electrode ground wire not correctly connected	Clean connections and retighten. Replace ground wire if damaged.
	Kettle pilot electrode lead wire has a short	Replace part (see Parts manual).
Kettle pilot igniter not functioning correctly	Replace part (see Parts manual).	
Kettle burner regulator not functioning correctly	Replace part (see Parts manual).	









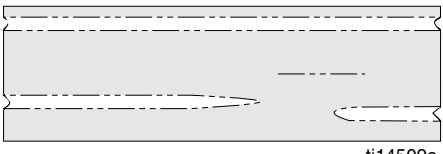
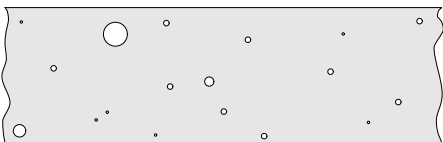

<b>Problem</b>	<b>Cause</b>	<b>Solution</b>
Kettle main burners do not ignite or are not burning correctly	Kettle gas safety valve knob not at correct position	Turn knob to ON position (see Operation manual).
	Kettle temperature control dial set at a lower temperature than material temperature	Turn kettle temperature control dial to temperature 25° F (13.9° C) higher than material temperature.
	Kettle gas safety valve not functioning correctly	See Repair manual and replace part if it fails diagnostic testing.
	Burner and/or gas lines plugged	Unplug holes and lines. Isolate all gas regulators if clearing line with forced air (see page 12).
	Kettle temperature control not functioning correctly	Replace part (see Parts manual).
	Gas lines have been disconnected	Connect and tighten hose fittings. Check for gas leaks.
	Incorrect flame length and/or gas pressure	Adjust flame and pressure (see page 11).
	Kettle gas safety valve knob not at correct position	Replace part (see Parts manual).
Kettle main burners do not shut off	Kettle temperature control dial is not turned to a setting lower than material temperature	Turn kettle temperature control dial to a setting 25° F (13.9° C) (minimum) lower than material temperature.
	Kettle temperature control not functioning correctly	Replace part (see Parts manual).
	Kettle gas safety valve not functioning correctly	Replace part if it fails diagnostic testing (see page 5).
Kettle main burner does not turn on	Kettle temperature control dial is not turned to a setting higher than material temperature	Turn kettle temperature control dial to a setting 25° F (13.9° C) (minimum) higher than material temperature.
	Kettle temperature control not functioning correctly	Replace part (see Parts manual).
	Kettle gas safety valve not functioning correctly	Replace part if it fails diagnostic test (see page 5).
Thermometer not matching material temperature in kettle	Material has not reached temperature control set point	Allow time for material to reach operating temperature.
	Material not fully obligated	Agitate material.
	Cool or windy ambient conditions	Move ThermoLazer™ out of cool windy conditions. Discharge material and check thermometer.
	Thermometer calibrated incorrectly	Calibrate thermometer (see page 7).
	Kettle temperature control calibrated incorrectly	See Repair manual and replace part if it can not be calibrated. See Parts manual 313880.
	Thermometer not functioning correctly	Replace part (see Parts manual).
	Kettle temperature control not functioning correctly	Replace part (see Parts manual).
	Kettle gas safety valve not functioning correctly	Replace part if it fails diagnostic test (see page 5).
Incorrect flame length and/or gas pressure	Adjust flame and pressure (see page 11).	

Problem	Cause	Solution
SmartDie™ screed box IR burner does not ignite, does not remain ignited, or can not change heat output	Empty LP-gas tank	Replace with full tank.
	LP-gas tank shut-off valve closed	Open LP-gas tank shut-off valve.
	Gas supply hose not connected to tank	Connect gas supply hose.
	Gas lines leaking or disconnected	Check for gas leaks. Connect and tighten fittings.
	Not allowing time for IR burner thermocouple to sense heat	See Operation manual.
	IR burner regulator/flow control valve not functioning correctly	Replace part (see Parts manual).
	IR burner safety shut-off valve not functioning correctly	Replace part (see Parts manual).
	IR burner thermocouple not functioning correctly	Replace part (see Parts manual).
Torch does not ignite	Empty LP-gas tank	Replace with full tank.
	LP-gas tank shut-off valve closed	Open LP-gas tank shut-off valve.
	Torch manual gas shut-off valve closed	Open manual shut-off valve.
	Gas supply hose not connected to tank	Connect gas supply hose.
	Gas lines leaking or disconnected	Check for gas leaks. Connect and tighten fittings.
	Torch assembly not functioning correctly	Replace part (see Parts manual).
PaddleMax™ agitator handle is hard to move	Material is cold	Allow time for material to reach operating temperature
	Bushings are worn	Replace bushings (see Parts manual).
	Linkage ball rod ends need lubrication	Add grease
	Foreign material lodged between agitator and kettle	Remove material in kettle and <b>CAREFULLY</b> dislodge and remove foreign material.
ControlFlow™ gate valve difficult to open or close	Cold material temperature	Heat material to operating temperature. Make sure thermometer is free to move.
	Gate sticking in guides	Check for excess material in guides. Apply heat as required and remove excess material. Add grease to lubricate guides.
	Bushings are worn	Replace bushings (see Parts manual).
ControlFlow™ gate valve leaking	Gate not completely closed	Close gate completely.
	Foreign material lodged in gate opening	<b>CAREFULLY</b> dislodge and remove foreign material.

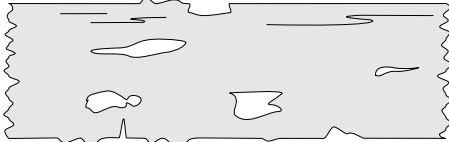
Problem	Cause	Solution
SmartDie™ screed box leaking	Foreign material in screed box discharge opening	<b>CAREFULLY</b> dislodge and remove foreign material.
	Dirty screed box	<b>CAREFULLY</b> clean box. All moving parts need to be free of debris.
	Spring broken	Replace spring (see page 13).
	Incorrect deployment rod linkage length	Adjust length (see page 14).
	Incorrectly adjusted SmartDie™ screed box/bead dispenser box actuator	Adjust lever (see page 14).
	Worn screed box gate	Replace gate (see Parts manual 313880).
	Worn screed box trough	Replace trough (see Parts manual 313880).
Excessive material buildup when starting and stopping extruding	Screed box not adjusted to ground	See Operation manual.
	Screed box open when ThermoLazer™ is stationary	Synchronize ThermoLazer™ and screed box motion.
	Foreign material in screed box discharge opening	<b>CAREFULLY</b> dislodge and remove foreign material.
	Dirty screed box	<b>CAREFULLY</b> clean box. All moving parts need to be free of debris.
Beads not discharging or discharging unevenly	Low bead level in bead hopper	Fill bead hopper.
	Bead dispenser doors closed	Open doors as required to obtain desired flow pattern width.
	Bead dispenser drive wheel not engaged	Secure bead dispenser wheel (see page 14).
	Bead dispenser drive wheel slipping	Tighten. Check air pressure (see page 14).
	Debris in discharge opening of bead dispenser	Remove debris.
	Debris on ThermoLazer™ tire or bead dispenser wheel	Remove debris.
	Moisture in beads	Remove wet beads. Dry hopper, bead hoses and bead dispenser. Fill hopper with dry beads.
Beads not discharging at required flow rate	Bead dispenser flow rate lever not correctly set	Rotate flow rate lever to correct position.
	Bead dispenser drive wheel slipping	Tighten wheel and check tire pressure (see page 14).
	Bead dispenser doors not fully open	Open door fully.
	Moisture in beads	Remove wet beads. Dry hopper, bead hoses and bead dispenser. Fill hopper with dry beads.
	Moisture on road surface	Allow road surface moisture to dry.
	Rough road surface	Smooth road surface.
	Bead Dispenser low on material	Add material to Bead Hopper.

## Applying Material

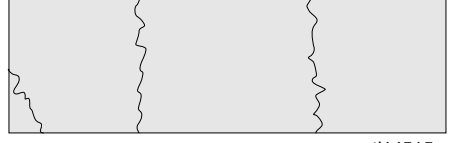
Problem	Cause	Solution
Ragged line edges when extruding	Dirty screed box	<b>CAREFULLY</b> clean box. Discharge opening and die plate runners need to be free of debris.
	Cold material temperatures	Heat material as required.
	Marking speed too fast	Slow Thermolazer™ speed.
	Material thickness too think	Slow Thermolazer™ speed and keep screed box filled.
Rough material surface when extruding	Overheated material	Reduce heat.
	Moisture on road surface	Allow road surface moisture to dry.
	Rough road surface	Smooth road surface.
	Screed box low on material	Add material to screed box.
<b>EXAMPLES:</b>		
<p><b>Correct line application</b> will produce a full straight line with sharp edges; correct color, thickness and width; a firm bond to the surface; and have uniform reflectivity.</p>  <p style="text-align: center;">ti14507a</p>		
<p>Insufficient adhesion (material bulges at beginning of line)</p>  <p style="text-align: center;">ti14508a</p>	<ul style="list-style-type: none"> <li>• Material temperature too low</li> <li>• Thermolazer™ speed too fast</li> <li>• Debris on road</li> <li>• Surface temperature too cold</li> </ul>	<ul style="list-style-type: none"> <li>• Raise material temperature</li> <li>• Decrease speed of Thermolazer™</li> <li>• Clear debris from road</li> <li>• Wait for temperature of surface to raise</li> </ul>
<p>Rough and bumpy line</p>  <p style="text-align: center;">ti14509a</p>	<ul style="list-style-type: none"> <li>• Debris on surface</li> <li>• Crust from overheated material</li> <li>• Debris caught in die</li> <li>• Material not covering road high spot</li> </ul>	<ul style="list-style-type: none"> <li>• Clear debris from surface</li> <li>• Lower material temperature</li> <li>• Clean debris from die</li> <li>• Adjust screed box line thickness</li> </ul>
<p>Gas bubbles in line</p>  <p style="text-align: center;">ti14510a</p>	<ul style="list-style-type: none"> <li>• Moisture or solvent on surface</li> <li>• Material is overheated</li> </ul>	<ul style="list-style-type: none"> <li>• Remove solvent from surface</li> <li>• Lower temperature of material</li> </ul>

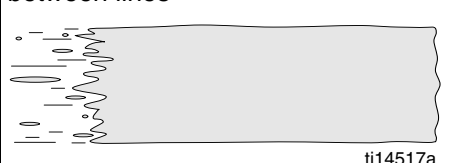
Problem	Cause	Solution
<p>Ragged edges and gaps in line</p>  <p>ti14511a</p>	<ul style="list-style-type: none"> <li>• Material temperature is too low</li> <li>• Thermolazer™ speed is too fast</li> </ul>	<ul style="list-style-type: none"> <li>• Raise material temperature</li> <li>• Wait for change in ambient conditions to remove moisture</li> <li>• Reduce Thermolazer™ speed</li> </ul>
<p>Swollen rounded line</p>  <p>ti14512a</p>	<ul style="list-style-type: none"> <li>• Material temperature is too high</li> </ul>	<ul style="list-style-type: none"> <li>• Lower material temperature</li> </ul>
<p>Material shadows on sides</p>  <p>ti14513a</p>	<ul style="list-style-type: none"> <li>• Uneven road surface</li> <li>• Die is not evenly riding on substrate</li> </ul>	<ul style="list-style-type: none"> <li>• Apply to even road surfaces</li> <li>• Remove debris from screed box lever rod</li> <li>• Inspect/replace damaged screed box lever rod/lever arm</li> </ul>
<p>Line is wavy</p>  <p>ti14514a</p>	<ul style="list-style-type: none"> <li>• Strong road surface camber</li> <li>• Incorrect Thermolazer™ operation</li> </ul>	<ul style="list-style-type: none"> <li>• Apply so camber does not influence application</li> <li>• Use correct application methods (for example, try locking swivel wheel)</li> </ul>
<p>Cracks in line</p>  <p>ti14515a</p>	<ul style="list-style-type: none"> <li>• Cracks in road surface</li> <li>• Temperature stress from overheating</li> <li>• Material applied too cold</li> <li>• Material applied too thin</li> </ul>	<ul style="list-style-type: none"> <li>• Repair cracks</li> <li>• Lower temperature in material</li> <li>• Increase material temperature</li> <li>• Slow Thermolazer™ speed to apply thicker material</li> </ul>
<p>Rough edges and lines in surface</p>  <p>ti14516a</p>	<ul style="list-style-type: none"> <li>• Material temperature is too low</li> <li>• Material is overheated or scorched</li> <li>• Moisture in road surface</li> </ul>	<ul style="list-style-type: none"> <li>• Raise material temperature</li> <li>• Lower material temperature</li> <li>• Wait until road surface is dry</li> </ul>
<p>Jagged line ends; material drips between lines</p>  <p>ti14517a</p>	<ul style="list-style-type: none"> <li>• Die does not fully close</li> <li>• Debris caught in die</li> <li>• Worn die gate</li> <li>• Worn die trough</li> <li>• Broken spring</li> </ul>	<ul style="list-style-type: none"> <li>• Clean die</li> <li>• Clear debris from die</li> <li>• Replace die gate</li> <li>• Replace die trough</li> <li>• Replace spring</li> </ul>

## Technical Data

Fuel:	Liquefied petroleum gas (LP-gas) (propane vapor)
Gas supply pressure (maximum):	250 psi (17.24 bar)
Kettle burner inlet pressure:	11 in. w.c. (2.7 kPa)
IR burner inlet pressure:	12 psi (.83 bar)
Torch inlet pressure:	18 psi (1.24 bar)
Kettle main burner heating capacity (maximum):	Two (2) burners; each burner rated at 10,100 btu/hr (2.96 kW)
Kettle pilot burner heating capacity (maximum):	3800 btu/hr (1.11 kW)
IR burner heating capacity (maximum):	14,000 btu/hr (4.10 kW)
Torch heating capacity (maximum):	100,000 btu/hr (29.31 kW)
Kettle holding capacity (maximum):	300 lb (136 kg) (thermoplastic traffic marking compound materials)
Kettle Temperature (maximum):	450° F (232° C)
Kettle Temperature (operating):	380° - 420° F (193° - 216° C) 60 psi (4.14 bar)
Tire pressure (rear wheels):	60 psi (4.14 bar)
Tire pressure (swivel wheel):	45 psi (3.10 bar)
Battery (Kettle Pilot Burner Igniter):	AA (1.5 V)
Bead Hopper Capacity (maximum):	80 lb (36.3 kg) Type II glass bead

## Dimensions

Weight:	295 lb (134 kg)
Length:	72 in. (1.83 m)
Height:	51 in. (1.30 m)
Width:	48 in. (1.22 m)

# Graco Standard Warranty

Graco warrants all equipment referenced in this document which is manufactured by Graco and bearing its name to be free from defects in material and workmanship on the date of sale to the original purchaser for use. With the exception of any special, extended, or limited warranty published by Graco, Graco will, for a period of twelve months from the date of sale, repair or replace any part of the equipment determined by Graco to be defective. This warranty applies only when the equipment is installed, operated and maintained in accordance with Graco's written recommendations.

This warranty does not cover, and Graco shall not be liable for general wear and tear, or any malfunction, damage or wear caused by faulty installation, misapplication, abrasion, corrosion, inadequate or improper maintenance, negligence, accident, tampering, or substitution of non-Graco component parts. Nor shall Graco be liable for malfunction, damage or wear caused by the incompatibility of Graco equipment with structures, accessories, equipment or materials not supplied by Graco, or the improper design, manufacture, installation, operation or maintenance of structures, accessories, equipment or materials not supplied by Graco.

This warranty is conditioned upon the prepaid return of the equipment claimed to be defective to an authorized Graco distributor for verification of the claimed defect. If the claimed defect is verified, Graco will repair or replace free of charge any defective parts. The equipment will be returned to the original purchaser transportation prepaid. If inspection of the equipment does not disclose any defect in material or workmanship, repairs will be made at a reasonable charge, which charges may include the costs of parts, labor, and transportation.

**THIS WARRANTY IS EXCLUSIVE, AND IS IN LIEU OF ANY OTHER WARRANTIES, EXPRESS OR IMPLIED, INCLUDING BUT NOT LIMITED TO WARRANTY OF MERCHANTABILITY OR WARRANTY OF FITNESS FOR A PARTICULAR PURPOSE.**

Graco's sole obligation and buyer's sole remedy for any breach of warranty shall be as set forth above. The buyer agrees that no other remedy (including, but not limited to, incidental or consequential damages for lost profits, lost sales, injury to person or property, or any other incidental or consequential loss) shall be available. Any action for breach of warranty must be brought within two (2) years of the date of sale.

**GRACO MAKES NO WARRANTY, AND DISCLAIMS ALL IMPLIED WARRANTIES OF MERCHANTABILITY AND FITNESS FOR A PARTICULAR PURPOSE, IN CONNECTION WITH ACCESSORIES, EQUIPMENT, MATERIALS OR COMPONENTS SOLD BUT NOT MANUFACTURED BY GRACO.** These items sold, but not manufactured by Graco (such as electric motors, switches, hose, etc.), are subject to the warranty, if any, of their manufacturer. Graco will provide purchaser with reasonable assistance in making any claim for breach of these warranties.

In no event will Graco be liable for indirect, incidental, special or consequential damages resulting from Graco supplying equipment hereunder, or the furnishing, performance, or use of any products or other goods sold hereto, whether due to a breach of contract, breach of warranty, the negligence of Graco, or otherwise.

## **FOR GRACO CANADA CUSTOMERS**

The Parties acknowledge that they have required that the present document, as well as all documents, notices and legal proceedings entered into, given or instituted pursuant hereto or relating directly or indirectly hereto, be drawn up in English. Les parties reconnaissent avoir convenu que la rédaction du présente document sera en Anglais, ainsi que tous documents, avis et procédures judiciaires exécutés, donnés ou intentés, à la suite de ou en rapport, directement ou indirectement, avec les procédures concernées.

# Graco Information

**TO PLACE AN ORDER**, contact your Graco distributor or call to identify the nearest distributor.  
**Toll Free:** 1-800-690-2894.

*All written and visual data contained in this document reflects the latest product information available at the time of publication.  
Graco reserves the right to make changes at any time without notice.*

*This manual contains English. MM 313879*

**Graco Headquarters:** Minneapolis

**International Offices:** Belgium, China, Japan, Korea

**GRACO INC. P.O. BOX 1441 MINNEAPOLIS, MN 55440-1441**

Copyright 2008, Graco Inc. is registered to I.S. EN ISO 9001

[www.graco.com](http://www.graco.com)

Download from [Www.Somanuals.com](http://Www.Somanuals.com). All Manuals Search And Download.



## Free Manuals Download Website

<http://myh66.com>

<http://usermanuals.us>

<http://www.somanuals.com>

<http://www.4manuals.cc>

<http://www.manual-lib.com>

<http://www.404manual.com>

<http://www.luxmanual.com>

<http://aubethermostatmanual.com>

Golf course search by state

<http://golfingnear.com>

Email search by domain

<http://emailbydomain.com>

Auto manuals search

<http://auto.somanuals.com>

TV manuals search

<http://tv.somanuals.com>