

Instructions—Parts List



HYDRA-SPRAY®

President® and Monark® Pumps

306981AD

For airless and air-assisted spraying of finishing materials.



Important Safety Instructions
Read all warnings and instructions in this manual.
Save these instructions.

30:1 RATIO PRESIDENT PUMPS

3600 psi (25 MPa, 248 bar) Maximum Fluid Working Pressure
120 psi (0.8 MPa, 8 bar) Maximum Air Input Pressure

Part No. 221075, Series C

55 Gallon (200 Liter) Drum Size



II 1/2 G T3
ITS03ATEX11228

Part No. 243664, Series A

Stubby Size



II 2 G T3

Part No. 223586, Series B

Stubby Size



II 2 G T3

15:1 RATIO MONARK PUMPS

1500 psi (10.5 MPa, 105 bar) Maximum Fluid Working Pressure
100 psi (0.7 MPa, 7 bar) Maximum Air Input Pressure

Part No. 239327, Series A

Stubby Size



II 1/2 G T3
ITS03ATEX11228

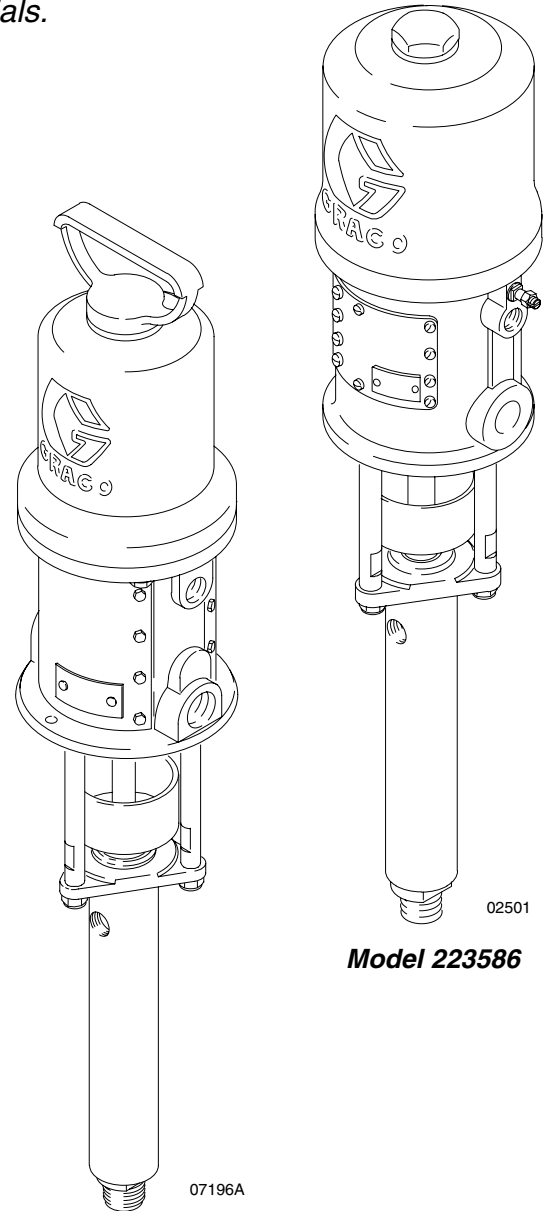

Model 239327

Model 223586



PROVEN QUALITY. LEADING TECHNOLOGY.

Table of Contents

Warnings	2
Installation	5
Operation	9
Troubleshooting	12
Service	13
Parts	16
Technical Data	20
Dimensions	23
Mounting Hole Layout	23
Graco Standard Warranty	24
Graco Information	24

Symbols

Warning Symbol



This symbol alerts you to the possibility of serious injury or death if you do not follow the instructions.

Caution Symbol



This symbol alerts you to the possibility of damage to or destruction of equipment if you do not follow the instructions.

! WARNING



INSTRUCTIONS

EQUIPMENT MISUSE HAZARD

Equipment misuse can cause the equipment to rupture or malfunction and result in serious injury.

- This equipment is for professional use only.
- Read all instruction manuals, tags, and labels before operating the equipment.
- Use the equipment only for its intended purpose. If you are uncertain about usage, call your Graco distributor.
- Do not alter or modify this equipment. Use only genuine Graco parts and accessories.
- Check equipment daily. Repair or replace worn or damaged parts immediately.
- Do not exceed the maximum working pressure of the lowest rated system component. Refer to the **Technical Data** on page 20 for the maximum working pressure of this equipment.
- Use fluids and solvents which are compatible with the equipment wetted parts. Refer to the **Technical Data** section of all equipment manuals. Read the fluid and solvent manufacturer's warnings.
- Do not use hoses to pull equipment.
- Route hoses away from traffic areas, sharp edges, moving parts, and hot surfaces. Do not expose Graco hoses to temperatures above 180°F (82°C) or below -40°F (-40°C).
- Wear hearing protection when operating this equipment.
- Do not lift pressurized equipment.
- Comply with all applicable local, state, and national fire, electrical, and safety regulations.

⚠ WARNING



SKIN INJECTION HAZARD

Spray from the gun, hose leaks, or ruptured components can inject fluid into your body and cause extremely serious injury, including the need for amputation. Fluid splashed in the eyes or on the skin can also cause serious injury.



- Fluid injected into the skin might look like just a cut, but it is a serious injury. **Get immediate surgical treatment.**
- Do not point the gun at anyone or at any part of the body.
- Do not put your hand or fingers over the spray tip.
- Do not stop or deflect leaks with your hand, body, glove or rag.
- Do not “blow back” fluid; this is not an air spray system.
- Always have the tip guard and the trigger guard on the gun when spraying.
- Check the gun diffuser operation weekly. Refer to the gun manual.
- Be sure the gun trigger safety operates before spraying.
- Lock the gun trigger safety when you stop spraying.
- Follow the **Pressure Relief Procedure** on page 9 whenever you: are instructed to relieve pressure; stop spraying; clean, check, or service the equipment; and install or clean the spray tip.
- Tighten all fluid connections before operating the equipment.
- Check the hoses, tubes, and couplings daily. Replace worn, damaged, or loose parts immediately. Permanently coupled hoses cannot be repaired; replace the entire hose.
- Use only Graco approved hoses. Do not remove any spring guard that is used to help protect the hose from rupture caused by kinks or bends near the couplings.



MOVING PARTS HAZARD

Moving parts, such as the air motor piston, can pinch or amputate your fingers.

- Keep clear of all moving parts when starting or operating the pump.
- Before servicing the equipment, follow the **Pressure Relief Procedure** on page 9 to prevent the equipment from starting unexpectedly.

WARNING



FIRE AND EXPLOSION HAZARD

Improper grounding, poor ventilation, open flames or sparks can cause a hazardous condition and result in a fire or explosion and serious injury.



- Ground the equipment and the object being sprayed. Refer to **Grounding** on page 5.
- If there is any static sparking or you feel an electric shock while using this equipment, **stop spraying immediately**. Do not use the equipment until you identify and correct the problem.
- Provide fresh air ventilation to avoid the buildup of flammable fumes from solvents or the fluid being sprayed.
- Keep the spray area free of debris, including solvent, rags, and gasoline.
- Electrically disconnect all equipment in the spray area.
- Extinguish all open flames or pilot lights in the spray area.
- Do not smoke in the spray area.
- Do not turn on or off any light switch in the spray area while operating or if fumes are present.
- Do not operate a gasoline engine in the spray area.



TOXIC FLUID HAZARD

Hazardous fluid or toxic fumes can cause serious injury or death if splashed in the eyes or on the skin, inhaled, or swallowed.

- Know the specific hazards of the fluid you are using.
- Store hazardous fluid in an approved container. Dispose of hazardous fluid according to all local, state and national guidelines.
- Always wear protective eyewear, gloves, clothing and respirator as recommended by the fluid and solvent manufacturer.

Installation

General Information

NOTE: Reference numbers and letters in parentheses in the text refer to the callouts in the figures and the parts drawing.

NOTE: Always use Genuine Graco Parts and Accessories, available from your Graco distributor. If you supply your own accessories, be sure they are adequately sized and pressure-rated for your system.

Fig. 2 is only a guide for selecting and installing system components and accessories. Contact your Graco distributor for assistance in designing a system to suit your particular needs.

Prepare the Operator

All persons who operate the equipment must be trained in the safe, efficient operation of all system components as well as the proper handling of all fluids. All operators must thoroughly read all instruction manuals, tags, and labels before operating the equipment.

Grounding

⚠ WARNING

FIRE AND EXPLOSION HAZARD
Before operating the pump, ground the system as explained below. Also read the section **FIRE AND EXPLOSION HAZARD** on page 4.

1. *Pump:* use a 12 gauge (1.5 mm²) minimum ground wire and clamp. See Fig. 1. Loosen the grounding lug locknut (W) and washer (X). Insert one end of the ground wire (Y) into the slot in lug (Z) and tighten the locknut securely. Connect the other end of the wire to a true earth ground. Order Part No. 238909.

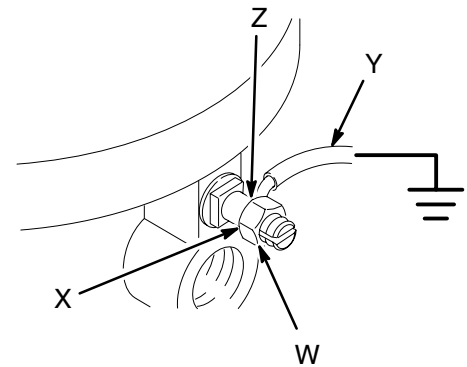

Fig. 1

0720

2. *Air and fluid hoses:* use only electrically conductive hoses.
3. *Air compressor:* follow manufacturer's recommendations.
4. *Spray gun:* ground through connection to a properly grounded fluid hose and pump.
5. *Fluid supply container:* follow your local code.
6. *Object being sprayed:* follow your local code.
7. *Solvent pails used when flushing:* follow your local code. Use only metal pails, which are conductive, placed on a grounded surface. Do not place the pail on a nonconductive surface, such as paper or cardboard, which interrupts the grounding continuity.
8. *To maintain grounding continuity when flushing or relieving pressure,* hold a metal part of the spray gun firmly to the side of a grounded metal pail, then trigger the gun.

Installation

Refer to the Typical Installation drawing (Fig. 2).

WARNING

A bleed-type master air valve (D) and a fluid drain valve (J) are required in your system. These accessories help reduce the risk of serious injury, including skin injection and splashing of fluid in the eyes or on the skin, and injury from moving parts if you are adjusting or repairing the pump.

The bleed-type master air valve relieves air trapped between this valve and the pump after the air is shut off. Trapped air can cause the pump to cycle unexpectedly. Locate the valve close to the pump. Order Part No. 113333.

The fluid drain valve assists in relieving fluid pressure in the displacement pump, hose, and gun. Triggering the gun to relieve pressure may not be sufficient. Order Part No. 238635.

Mounting Accessories

Mount the pump (A) to suit the type of installation planned. The pump dimensions and mounting hole layout are shown on page 23.

Air and Fluid Hoses

Ensure that you have an adequate compressed air supply. Refer to the performance chart on page 20 to find the air consumption of your pump.

Be sure all air and fluid hoses are properly sized and pressure-rated for your system. Use only electrically conductive air and fluid hoses. Fluid hoses must have spring guards on both ends.

Connect an electrically conductive fluid hose (L) to the pump's 3/8 npt(f) fluid outlet. Use of a short whip hose between the main fluid hose (L) and the gun (M) allows freer gun movement.

Connect a fluid suction hose or tube (N) to the pump's 3/4 npt(m) fluid intake.

Use an electrically conductive 1/2 in. I.D. (minimum) air hose (H) to supply air to the pump.

Air Line Accessories

Install the following accessories in the order shown in Fig. 2, using adapters as necessary:

- **An air line lubricator (C)** provides automatic air motor lubrication.
- **A bleed-type master air valve (D)** is required in your system to relieve air trapped between it and the air motor when the valve is closed (see the **WARNING** at left). Be sure the bleed valve is easily accessible from the pump, and is located **downstream** from the air regulator.
- **A pump runaway valve (B)** senses when the pump is running too fast and automatically shuts off the air to the motor. A pump which runs too fast can be seriously damaged.
- **An air regulator (E)** controls pump speed and outlet pressure by adjusting the air pressure to the pump. Locate the regulator close to the pump, but **upstream** from the bleed-type master air valve.
- **An air line filter (F)** removes harmful dirt and moisture from the compressed air supply.
- **A second bleed-type air valve (G)** isolates the air line accessories for servicing. Locate upstream from all other air line accessories.

Fluid Line Accessories

Install the following accessories in the positions shown in Fig. 2, using adapters as necessary:

- **A fluid drain valve (J)** is required in your system to relieve fluid pressure in the hose and gun (see the **WARNING** at left). Install the drain valve pointing down, but so the handle points up when the valve is opened.
- **A fluid filter (K)** filters harmful particles from the fluid.
- **A spray gun (M)** dispenses the fluid. The gun shown in Fig. 2 is an airless spray gun.

Installation

KEY

- A Pump
- B Pump Runaway Valve
- C Air Line Lubricator
- D Bleed-Type Master Air Valve (required, for pump)
- E Pump Air Regulator
- F Air Line Filter
- G Bleed-Type Master Air Valve (for accessories)
- H Air Supply Hose
- J Fluid Drain Valve (required)
- K Fluid Filter
- L Fluid Supply Hose
- M Spray Gun
- N Fluid Suction Hose
- Y Ground Wire (required; see page 5 for installation instructions)

Model 223586 Shown

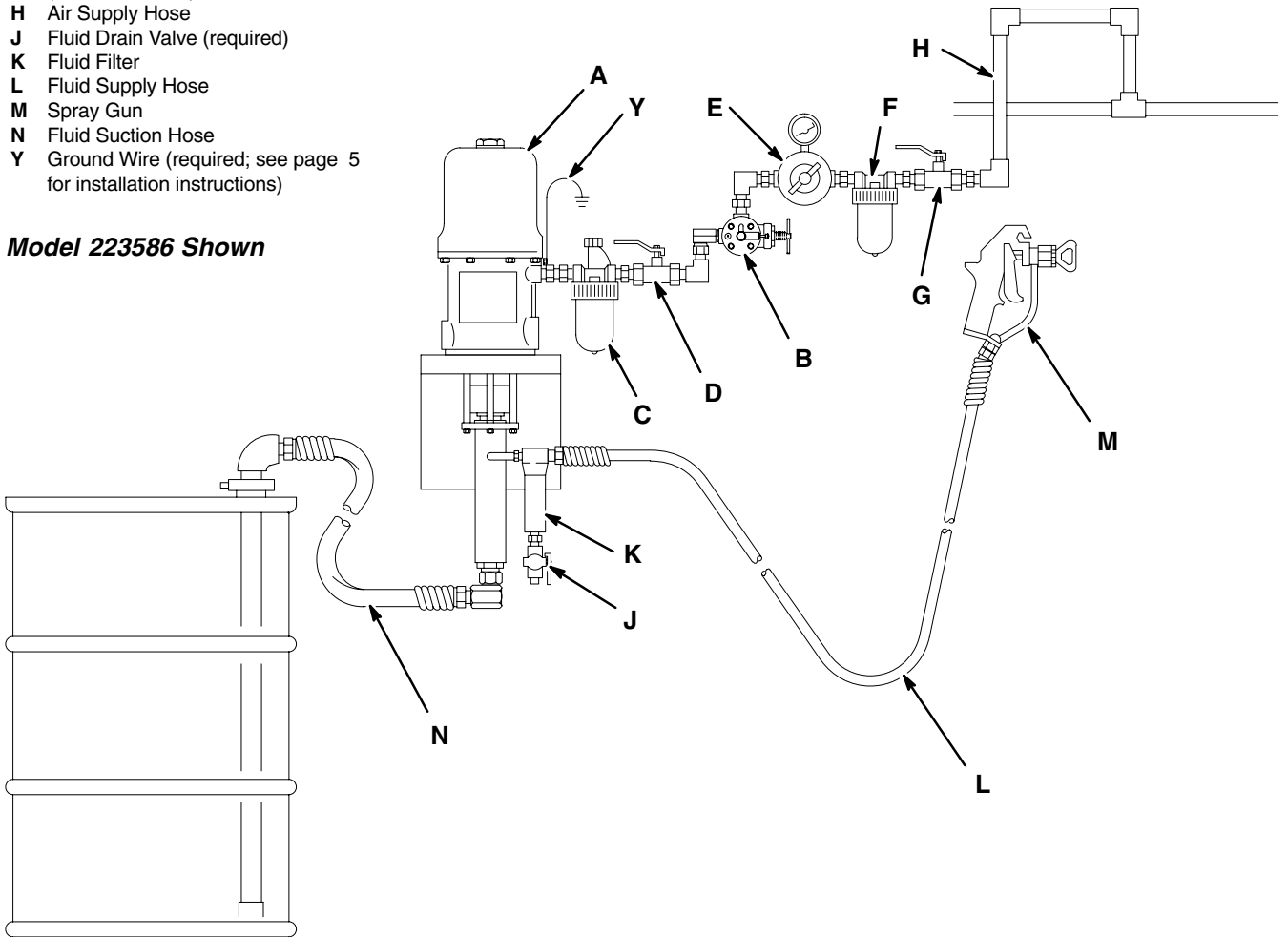

Fig. 2

02502

Operation

Pressure Relief Procedure

WARNING



SKIN INJECTION HAZARD

The system pressure must be manually relieved to prevent the system from starting or spraying accidentally. Fluid under high pressure can be injected through the skin and cause serious injury. To reduce the risk of an injury from injection, splashing fluid, or moving parts, follow the **Pressure Relief Procedure** whenever you:

- are instructed to relieve the pressure,
- stop spraying,
- check or service any of the system equipment,
- or install or clean the spray tip.

1. Lock the gun trigger safety.
2. Close the bleed-type master air valve (D, required in your system). See Fig. 2.
3. Unlock the gun trigger safety.
4. Hold a metal part of the gun firmly to the side of a grounded metal pail, and trigger the gun to relieve pressure.
5. Lock the gun trigger safety.
6. Open the drain valve (J, required in your system), having a container ready to catch the drainage.
7. Leave the drain valve open until you are ready to spray again.

*If you suspect that the spray tip or hose is completely clogged, or that pressure has not been fully relieved after following the steps above, **very slowly** loosen the tip guard retaining nut or hose end coupling and relieve pressure gradually, then loosen completely. Now clear the tip or hose.*

WARNING



MOVING PARTS HAZARD

Do not operate without the air motor plates (P, Fig. 3) in place. Pinching or amputation of fingers or hands may occur. See **MOVING PARTS HAZARD** on page 3.

Packing Nut

Keep the packing nut/wet-cup (36) filled with Graco Throat Seal Liquid (TSL) or compatible solvent, to help prolong the packing life. See Fig. 3.

WARNING

To reduce the risk of serious injury whenever you are instructed to relieve pressure, always follow the **Pressure Relief Procedure** at left.

The packing nut is torqued at the factory and is ready for operation. If it becomes loose and there is leaking from the throat packings, relieve pressure, then torque the nut to 18–20 ft–lb (24–27 N.m). Do this whenever necessary. Do not overtighten the packing nut.

Flush the Pump Before First Use

The pump is tested with lightweight oil, which is left in to protect the pump parts. If the fluid you are using may be contaminated by the oil, flush it out with a compatible solvent. See **Flushing** on page 11.

Operation

Starting and Adjusting the Pump

See Fig. 2 on page 7. Be sure the air regulator (E) and bleed-type master air valve (D) are closed. **Do not install the spray tip yet!**

Connect a suction hose (N) to the pump's fluid inlet. Hold a metal part of the spray gun (M) firmly to the side of a grounded metal pail and hold the trigger open. Then open the pump's bleed-type master air valve (D). Now slowly open the air regulator until the pump starts, about 40 psi (0.3 MPa, 3 bar).

Cycle the pump slowly until all the air is pushed out and the pump and hoses are fully primed. Release the spray gun trigger and lock the trigger safety. The pump should stall against pressure when the trigger is released.

WARNING

To reduce the risk of serious injury whenever you are instructed to relieve pressure, always follow the **Pressure Relief Procedure** on page 9.

Relieve the pressure. Install the spray tip as explained in your separate gun manual.

With the pump and lines primed, and with adequate air pressure and volume supplied, the pump will start and stop as the spray gun is opened and closed. In a circulating system, the pump will run continuously and will speed up or slow down as supply demands until the air supply is shut off.

Use an adequately sized air regulator (E) to control the pump speed and the fluid pressure. Always use the lowest air pressure necessary to get the desired results. Higher pressures waste fluid and cause premature wear of the pump packings and spray tip.

WARNING

COMPONENT RUPTURE HAZARD



To reduce the risk of overpressurizing your system, which could cause component rupture and serious injury, *never exceed the Maximum Air Input Pressure* marked on the pump. Refer to the **Technical Data** on page 20.

CAUTION

Do not allow the pump to run dry. It will quickly accelerate to a high speed, causing damage. If your pump is running too fast, stop it immediately and check the fluid supply. If the container is empty and air has been pumped into the lines, refill the container and prime the pump and the lines, or flush and leave it filled with a compatible solvent. Eliminate all air from the fluid system.

A pump runaway valve (B), which shuts off the air supply to the pump if the pump accelerates beyond the pre-set speed, is available. See Fig. 2 on page 7. Contact your Graco distributor for further information.

Operation

Shutdown and Care of the Pump

⚠ WARNING

To reduce the risk of serious injury whenever you are instructed to relieve pressure, always follow the **Pressure Relief Procedure** on page 9.

For overnight shutdown, relieve the pressure. Always stop the pump at the bottom of the stroke to prevent the fluid from drying on the exposed displacement rod and damaging the throat packings.

Always flush the pump before the fluid dries on the displacement rod. See **Flushing** below.

Flushing

⚠ WARNING



FIRE AND EXPLOSION HAZARD

Before flushing, read the section **FIRE AND EXPLOSION HAZARD** on page 4. Be sure the entire system and flushing pails are properly grounded. Refer to **Grounding** on page 5.

Flush the pump:

- Before the first use
- When changing colors or fluids
- Before fluid can dry or settle out in a dormant pump (check the pot life of catalyzed fluids)
- Before storing the pump.

Flush with a fluid that is compatible with the fluid you are pumping and with the wetted parts in your system. Check with your fluid manufacturer or supplier for recommended flushing fluids and flushing frequency.

If the pump is being used to supply a circulating system, allow the solvent to circulate until the pump is thoroughly flushed.

⚠ CAUTION

Never leave water or water-base fluid in the pump overnight. If you are pumping water-base fluid, flush with water first, then with a rust inhibitor such as mineral spirits. Relieve the pressure, but leave the rust inhibitor in the pump to protect the parts from corrosion.

Model 223586 Shown

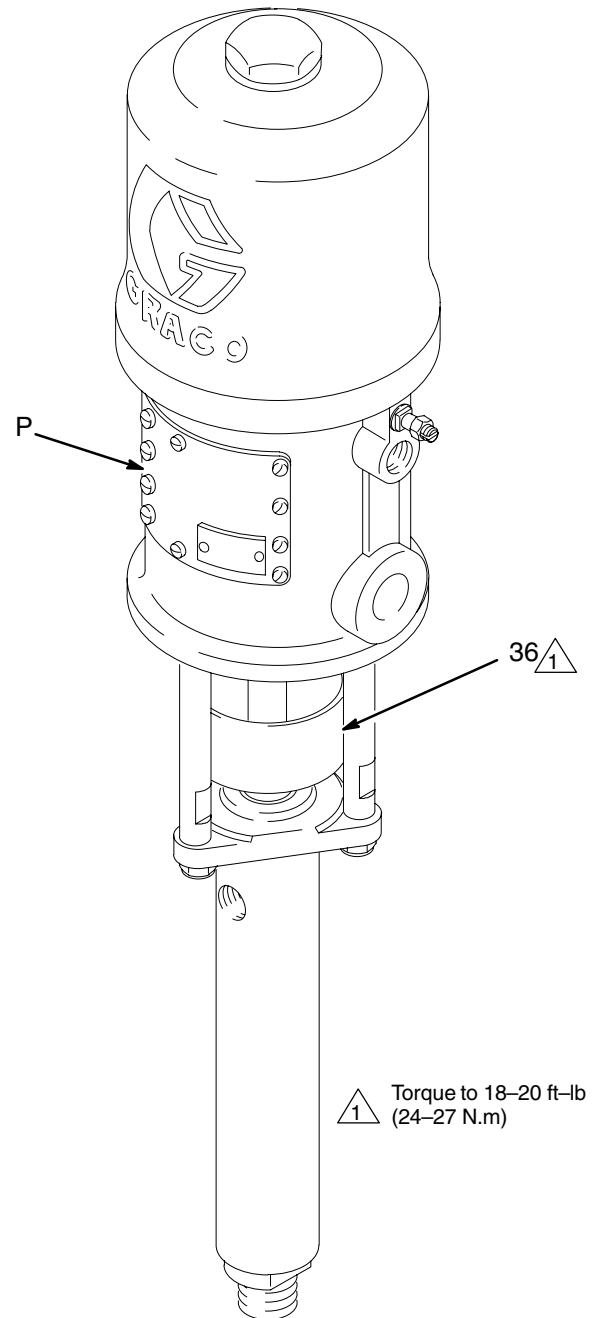

Fig. 3

02501

Troubleshooting

NOTE: Check all possible problems and solutions before disassembling the pump.

PROBLEM	CAUSE	SOLUTION
Pump fails to operate.	Restricted line or inadequate air supply.	Clear line; increase air supply.
	Insufficient air pressure; closed or clogged air valves, etc.	Open, clean.
	Exhausted fluid supply.	Refill; purge all air from pump and fluid lines.
	Damaged air valving mechanism; stalling.	Service air motor (see manual, supplied).
	Dried fluid seizure of displacement rod (26).	Clean rod; check or replace throat packings (18, 23); always stop pump at bottom of stroke and keep wet-cup filled with compatible solvent.
Pump operates but output is low on both strokes.	Restricted line or inadequate air supply.	Clear line; increase air supply.
	Insufficient air pressure; closed or clogged air valves, etc.	Open, clean.
	Exhausted fluid supply.	Refill; purge all air from pump and fluid lines.
	Clogged fluid line, valves, etc.	Clear*.
	Packing nut (36) is too tight.	Loosen (see page 9).
	Loose packing nut (36) or worn throat packings (18, 23).	Tighten packing nut (see page 9); replace throat packings (see page 14).
Pump operates but output is low on down stroke.	Held open or worn intake valve.	Clear; service. See page 14.
Pump operates but output is low on down stroke.	Held open or worn fluid piston valve or packings (18, 23).	Clear; service. See page 14.
Erratic or accelerated operation.	Exhausted fluid supply.	Refill; purge all air from pump and fluid lines.
	Held open or worn intake valve.	Clear; service. See page 14.
	Held open or worn fluid piston valve or packings (18, 23).	Clear; service. See page 14.

* To determine if the fluid hose or gun is obstructed, relieve the pressure. Disconnect the fluid hose and place a container at the pump fluid outlet to catch any fluid. Turn on the air just enough to start the pump (about 20–40 psi [0.14–0.28 MPa, 1.4–2.8 bar]). If the pump starts when the air is turned on, the obstruction is in the fluid hose or gun.

Service

Disconnecting the Displacement Pump

Model 223586 Shown

WARNING

To reduce the risk of serious injury whenever you are instructed to relieve pressure, always follow the **Pressure Relief Procedure** on page 9.

1. Flush the pump if possible. Stop the pump at the bottom of its stroke. Relieve the pressure.
2. Disconnect the air and fluid hoses. Remove the pump from its mounting. Note the relative position of the pump's fluid outlet to the air motor's air inlet.
3. See Fig. 4. (For Model 221075, refer also to the Parts Drawing on page 16.) Unscrew the tie rod locknuts (4) from the tie rods (12). Remove the cotter pin (3). Unscrew the displacement rod (26) from the air motor (14) or connecting rod (37, Model 221075 only). Carefully pull the displacement pump (15) off the air motor (14). Inspect the o-ring (7).
4. Refer to page 14 for displacement pump service. To service the air motor, refer to the separate air motor manual, supplied.

Reconnecting the Displacement Pump

1. Lubricate the o-ring (7) and place it on the displacement rod (26). Orient the pump's fluid outlet to the air motor's air inlet as was noted in step 2 under **Disconnecting the Displacement Pump**. Position the displacement pump (15) on the tie rods (12). See Fig. 4.
2. Screw the locknuts (4) onto the tie rods (12) loosely. Screw the displacement rod (26) into the shaft of the air motor (14) or the connecting rod (37, Model 221075 only) until the pin holes align. Install the cotter pin (3).
3. Mount the pump and reconnect all hoses. Reconnect the ground wire if it was disconnected during repair. Torque the packing nut/wet-cup (36) to 18–20 ft-lb (24–27 N.m). Fill the wet-cup with Graco Throat Seal Liquid or compatible solvent.
4. Tighten the tie rod locknuts (4) evenly, and torque as specified in Fig. 4.
5. Start the pump and run it at about 40 psi (3 bar) air pressure, to check that it is operating properly.

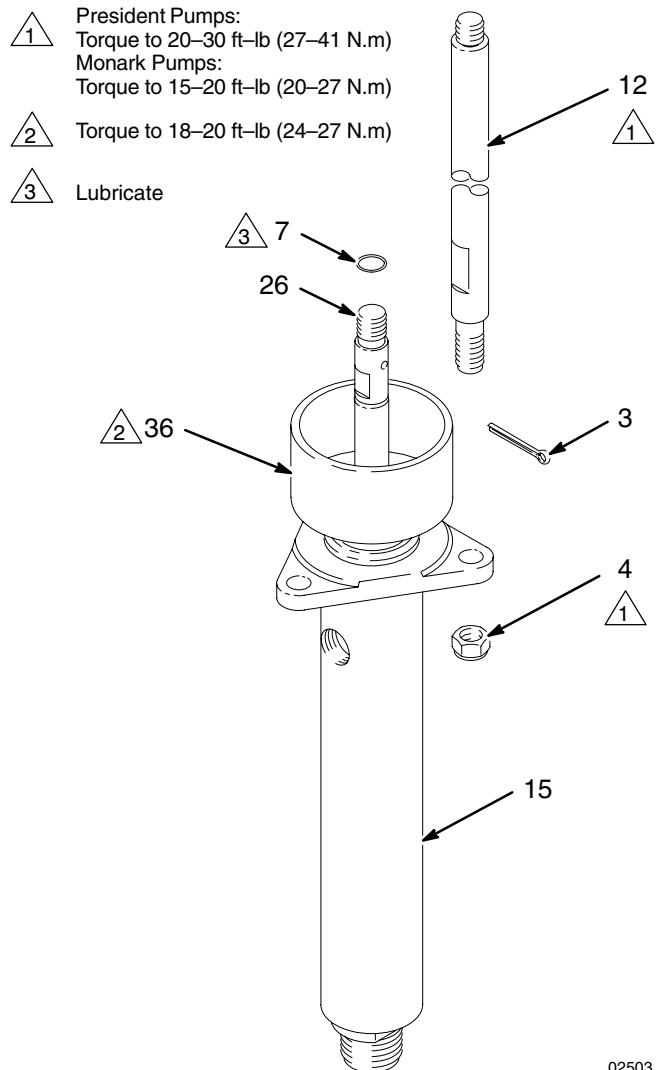
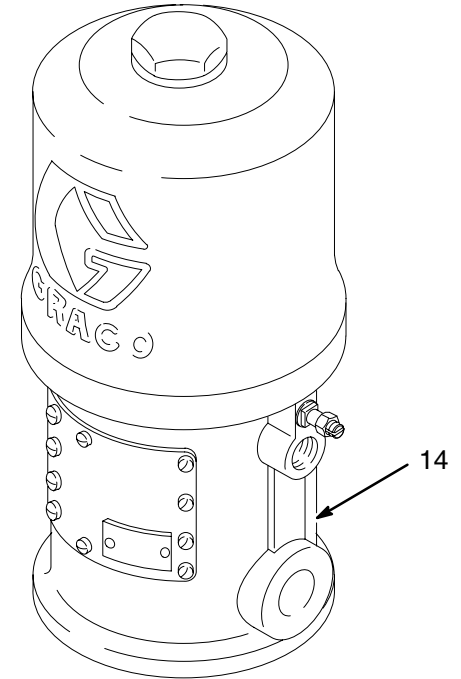

Fig. 4

02503

Service

Displacement Pump Service

Disassembly

When disassembling the pump, lay out all removed parts in sequence, to ease reassembly. Refer to Fig. 5.

NOTE: Repair Kit 235635 is available. For the best results, use all the new parts in the kit. Parts included in the kit are denoted with an asterisk, for example (17*).

Clean all the parts thoroughly when disassembling. Check them carefully for damage or wear, replacing parts as needed.

1. Remove the displacement pump from the air motor as explained on page 13.
2. Unscrew the intake valve housing (33) from the outlet housing (35). If it is difficult to remove, squirt penetrating oil around the threads and *gently* tap around the valve housing with a plastic hammer to loosen it. See Fig. 5.
3. Remove the ball stop pin (29), o-ring retainer (31), o-ring (30), guide (32) and ball (28) from the intake valve housing (33).
4. Loosen the packing nut (36). Push the displacement rod (26) down as far as possible, then pull it out the bottom of the outlet housing (35).
5. Secure the flats of the displacement rod (26) in a vise. Screw the piston stud (34) out of the rod. Remove the ball (17), retainer (22), packings (18, 23) and glands (24, 25).
6. Remove the packing nut (36), throat packings (18, 23) and glands (24, 25) from the outlet housing (35).
7. Inspect all parts for damage. Clean all parts and threads with a compatible solvent before reassembling. Inspect the polished surfaces of the displacement rod (26) and sleeve (20) for scratches, scoring or other damage, which can cause premature packing wear and leaking. To check, run a finger over the surface or hold the part up to the light at an angle. Be sure the ball seats of the piston (R) and intake valve housing (S) are not chipped or nicked. Replace any worn or damaged parts.

NOTE: If the sleeve (20) needs replacement and is hard to remove, contact your Graco distributor.

Reassembly

1. Lubricate the throat packings and install them in the outlet housing (35) one at a time as follows, *with the lips of the v-packings facing down*: the male gland (24*), one leather v-packing (18*), one PTFE (23*), one leather (18*), one PTFE (23*), one leather (18*), one PTFE (23*), and the female gland (25*). Install the packing nut (36) loosely. See the Throat Packing Detail in Fig. 5.
2. If you removed the sleeve (20), reinstall it in the outlet housing (35), making sure to replace the gasket (19*). *Be sure the tapered end of the sleeve faces down, toward the pump intake.*
3. Lubricate the piston packings and install them onto the piston stud (34) one at a time in the following order, *with the lips of the v-packings facing up*: the female gland (25*), one PTFE v-packing (23*), one leather v-packing (18*), one PTFE (23*), one leather (18*), one PTFE (23*), one leather (18*), the male gland (24*), and the packing retainer (22). See the Piston Packing Detail in Fig. 5.
4. Use thread sealant on the piston stud (34). Install the piston ball (17*) on the piston and screw the piston valve assembly into the displacement rod (26). Torque to 55–65 ft–lb (74–88 N.m).
5. Insert the displacement rod (26) into the bottom of the outlet housing (35), being careful not to scratch the sleeve (20). Push the rod straight up until it protrudes from the packing nut (36).
6. Install the ball (28*), guide (32), o-ring (30*), retainer (31), and ball stop pin (29) in the intake valve housing (33). Apply thread lubricant and screw the intake housing into the outlet housing (35). Torque to 55–65 ft–lb (74–88 N.m).
7. Reconnect the displacement pump to the air motor as explained on page 13.

Service

- 1 Torque to 18–20 ft-lb (24–27 N.m)
- 2 Torque to 55–65 ft-lb (74–88 N.m)
- 3 Lips of v-packings must face down.
- 4 Lips of v-packings must face up.
- 5 Tapered end must face down, toward pump intake (33).
- 6 Apply thread lubricant.
- 7 Lubricate.

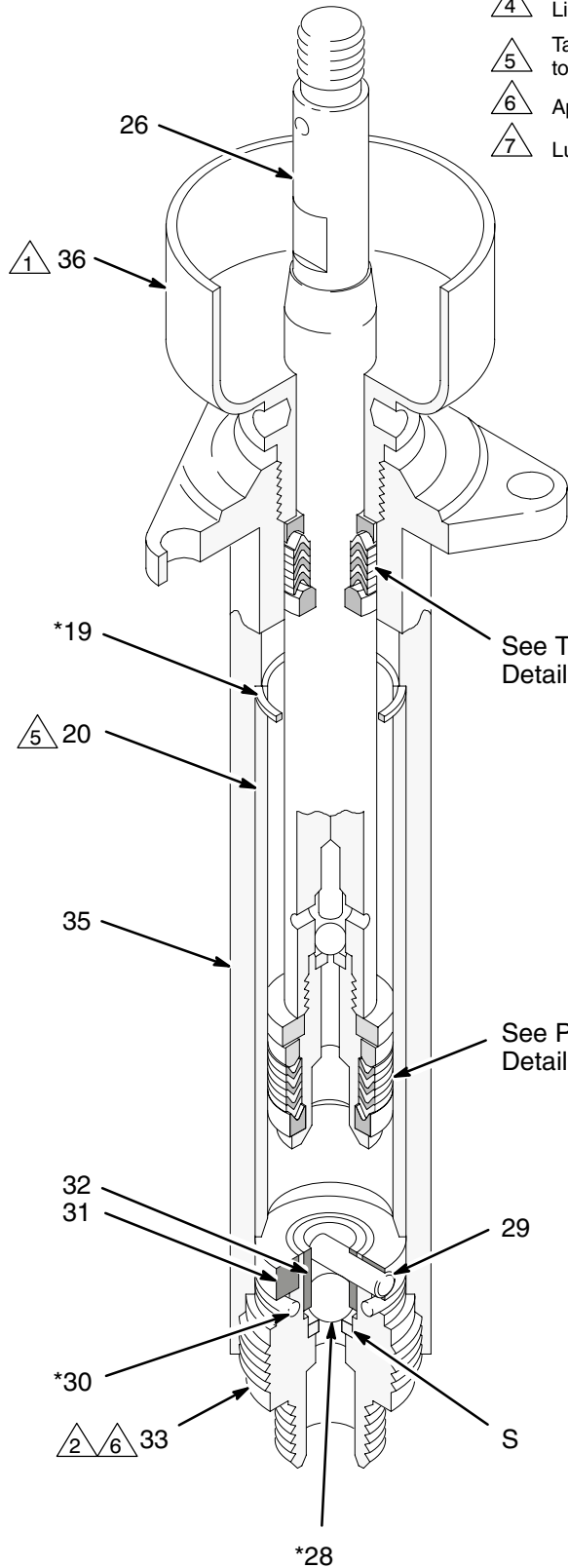

See Throat Packing Detail at Right

See Piston Packing Detail at Right

Throat Packing Detail

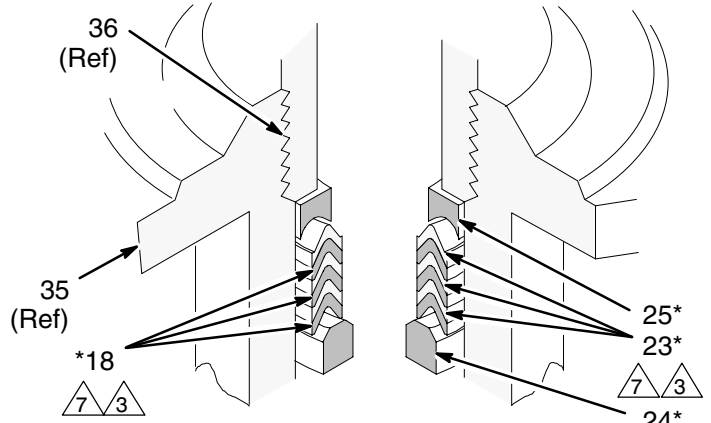

02505

Piston Packing Detail

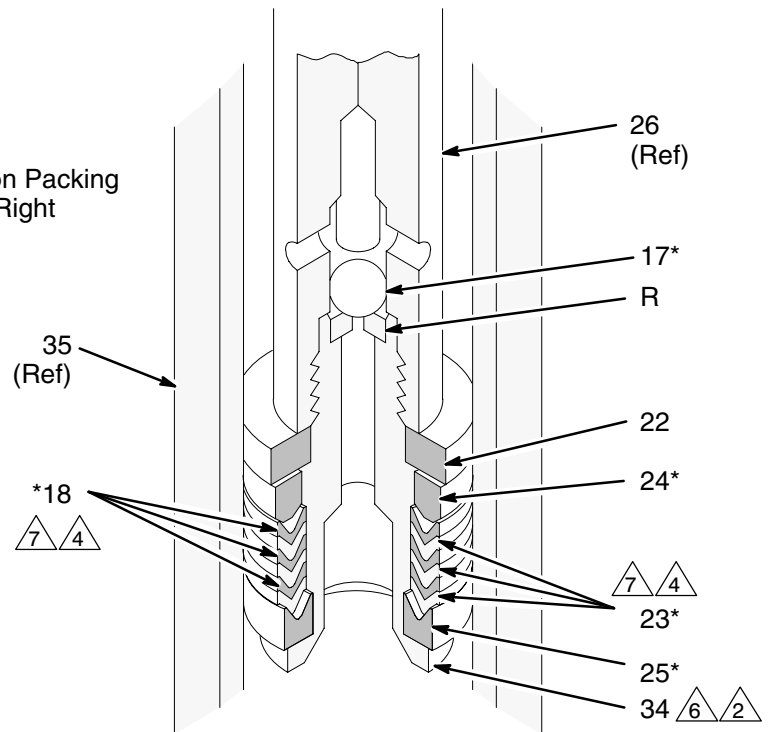

02505

Fig. 5

02504

Parts

Model 221075, Series C

30:1 Ratio President Pump, 55 gal. (200 liter) Drum Size

Ref. No.	Part No.	Description	Qty.
3✓	101946	PIN, cotter; stainless steel; 0.12" (3.2 mm) x 1.5" (38 mm)	1
4	101566	NUT, lock; 3/8-16	3
7	156082	SEAL, o-ring; nitrile rubber	1
12	168220	ROD, tie; carbon steel; 20" (508 mm), shoulder-to-shoulder	3
13	168222	TUBE, intake extension; aluminum	1
14	207352	AIR MOTOR See 306982 for parts	1
15	223587	DISPLACEMENT PUMP ASSY See pages 18-19	1
37	207698	ROD, connecting; carbon steel	1

✓ Keep these spare parts on hand to reduce down time.

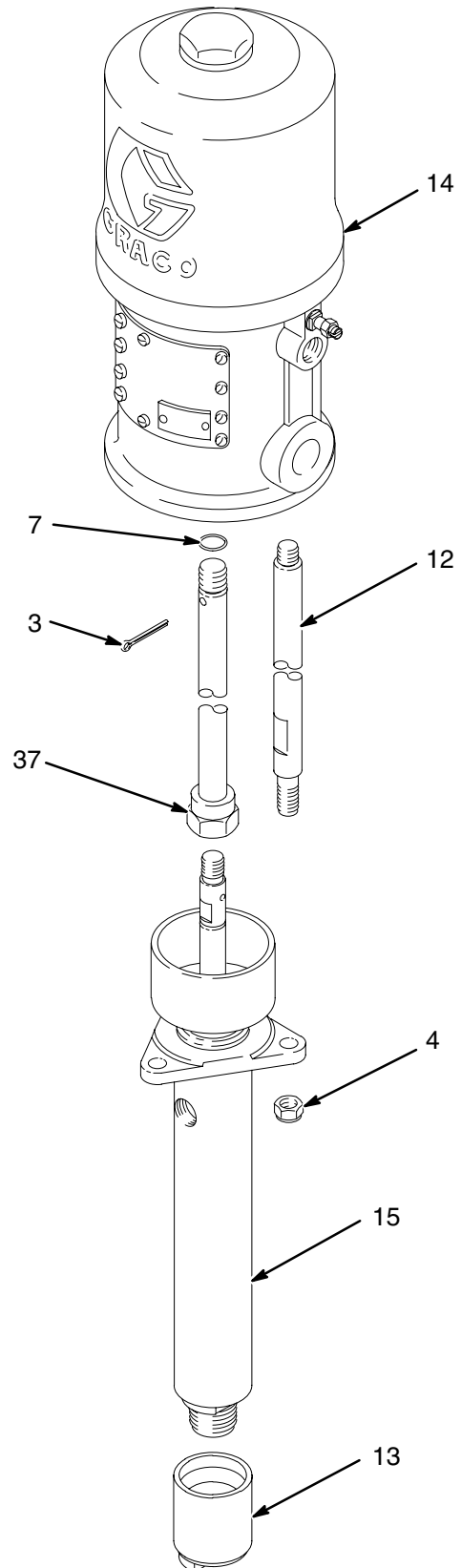

02507

Parts

Model 243664, Series A

Model 223586, Series B

30:1 Ratio President Pump, Stubby Size

Ref.

No.	Part No.	Description	Qty.
3✓	101946	PIN, cotter; stainless steel; 0.12" (3.2 mm) x 1.5" (38 mm)	1
4	101566	NUT, lock; 3/8-16	3
7	156082	SEAL, o-ring; nitrile rubber	1
12	168221	ROD, tie; carbon steel; 4.5" (114 mm), shoulder-to-shoulder	3
14	207352	AIR MOTOR See 306982 for parts	1
15	223587	DISPLACEMENT PUMP ASSY Model 223586 only	1
	243663	DISPLACEMENT PUMP ASSY Model 243664 only See pgs 18-19	1

✓ Keep these spare parts on hand to reduce down time.

Part No. 239327, Series A

15:1 Ratio Monark Pump, Stubby Size

Ref No.	Part No.	Description	Qty
3✓	101946	PIN, cotter; stainless steel; 0.12" (3.2 mm) x 1.5" (38 mm)	1
4	101566	NUT, lock; 3/8-16	3
7	154771	O-RING; buna-N	1
12	164722	ROD, tie; carbon steel; 4.375 in. (111 mm) shoulder to shoulder	3
14	215363	AIR MOTOR See 307043 for parts	1
15	223587	DISPLACEMENT PUMP ASSY See pgs 18-19	1

✓ Keep these spare parts on hand to reduce down time.

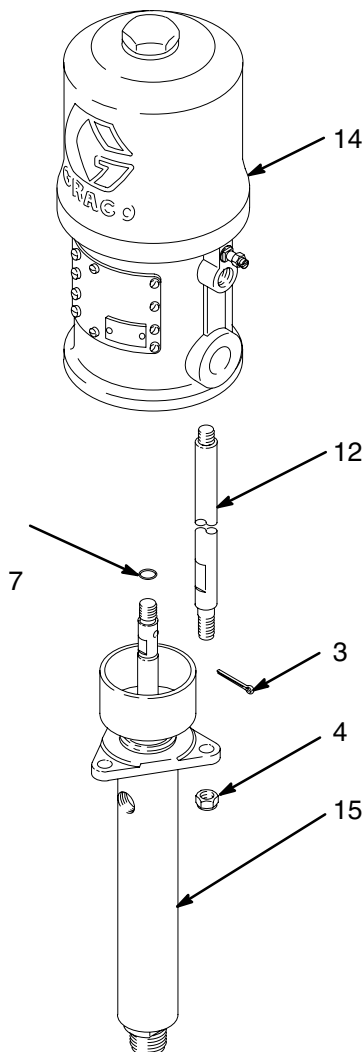

02503

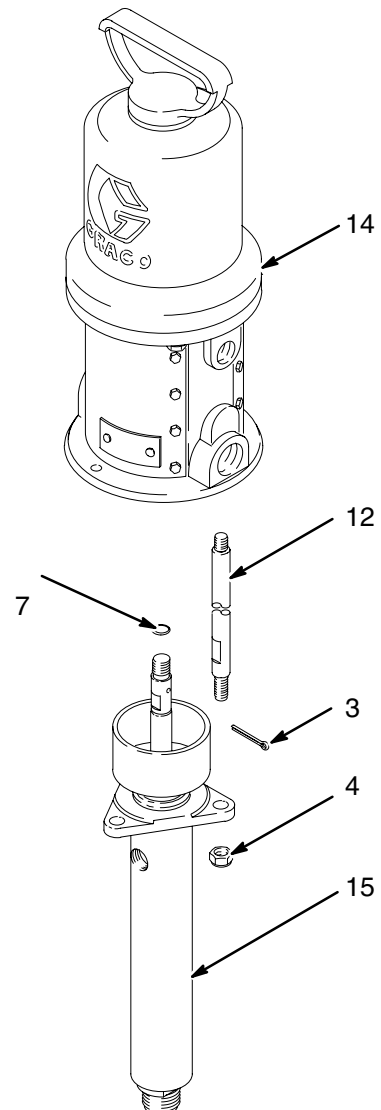

07197A

Parts

Model 243663, Series A

Model 223587, Series D

Severe-Duty Displacement Pumps

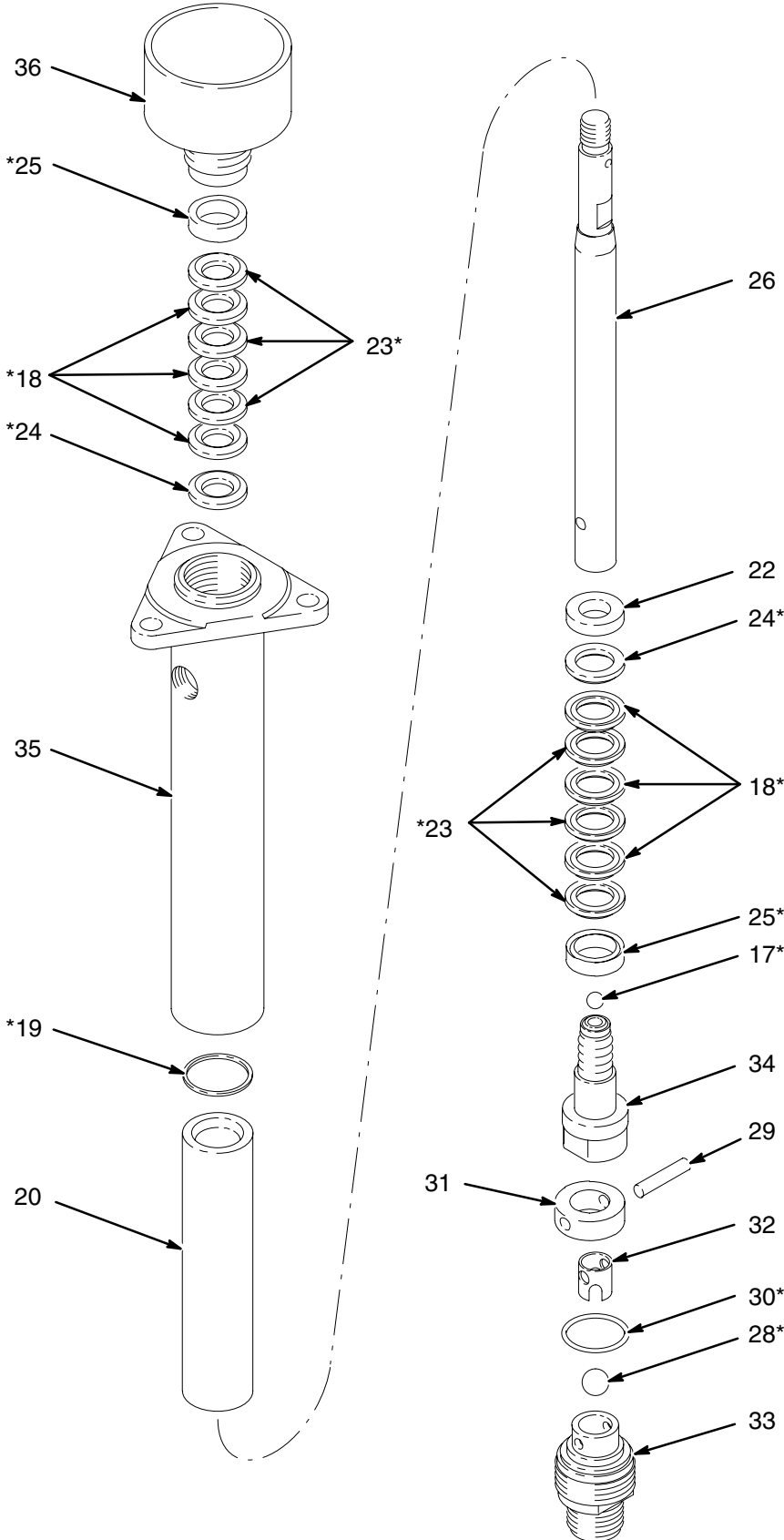

Parts

Model 243663, Series A Model 223587, Series D Severe-Duty Displacement Pumps

Ref. No.	Part No.	Description	Qty.	Ref. No.	Part No.	Description	Qty.
17*	105444	BALL, piston; stainless steel; 0.31" (7.9 mm) dia.	1	31	186183	RETAINER, o-ring; stainless steel	1
18*	see chart	V-PACKING	6	32	186187	GUIDE, ball; stainless steel	1
19*	164480	GASKET, flat; PTFE	1	33	223593	HOUSING, valve, intake; stainless steel with	
20	24C500	SLEEVE, housing; stainless steel	1			tungsten carbide seat	1
22✓	186184	RETAINER, packing; stainless steel	1	34	223565	STUD, piston; stainless steel with tungsten carbide seat	1
23*	see chart	V-PACKING	6	35	207011	HOUSING, outlet; carbon steel	1
24*	186182	GLAND, packing, male; stainless steel	2	36	207731	PACKING NUT/WET-CUP; carbon steel	1
25*	186181	GLAND, packing, female; stainless steel	2	38	172479	TAG, warning (not shown)	1
26	24C507	ROD, displacement; stainless steel	1	* These parts are included in Standard Repair Kits. See chart below for the packing materials of each kit.			
28*	105445	BALL, intake; stainless steel; 0.5" (13 mm) dia.	1	✓ Keep these spare parts on hand to reduce down time.			
29	186179	PIN, ball stop; stainless steel	1				
30*	165052	SEAL, o-ring; PTFE	1				

Repair Kit and Packing Chart

MODEL	REF NO	V – PACKING	MATERIAL	REPAIR KIT
223587	18	164477	Leather	6 leather and 6 PTFE V-packings are included in kit 235635
	23	164862	PTFE	
243663	18	◆	Tuff-Stack™	12 Tuff-Stack™ V-packings are included in kit 243687
	23		Tuff-Stack™	
	18	164477	Leather	6 leather and 6 UHMWPE V-packings are included in kit 223675
	23	108453	Ultra-High Molecular Weight Polyethylene	
	18	164862	PTFE	12 PTFE V-packings are included in kit 237725
	23	164862	PTFE	

◆ Packing Set 243621 contains 12 Tuff-Stack™ V-packings

Technical Data

Category	Data
Maximum fluid working pressure	<i>Models 221075, 223586, and 243664:</i> 3600 psi (25 MPa, 248 bar) <i>Model 239327:</i> 1500 psi (10.5 MPa, 105 bar)
Maximum air input pressure	<i>Models 221075, 223586, and 243664:</i> 120 psi (0.8 MPa, 8 bar) <i>Model 239327:</i> 100 psi (0.7 MPa, 7 bar)
Ratio	<i>Models 221075, 223586, and 243664:</i> 30:1 <i>Model 239327:</i> 15:1
Fluid flow at 60 cycles per minute	<i>Models 221075, 223586, and 243664:</i> 1 gallon (3.8 liters) per minute <i>Model 239327:</i> 0.7 gallon (2.6 liters) per minute
Recommended pump speed	15 to 25 cycles per minute
Weight	<i>Model 221075:</i> approximately 30 lb (14 kg) <i>Model 223586 and 243664:</i> approximately 24 lb (11 kg) <i>Model 239327:</i> approximately 18 lb (8 kg)
Wetted parts	Carbon Steel; Chrome and Zinc Plating; Tungsten Carbide; PTFE; Leather; AISI 304, 316, 420, 440, and 17-4 PH Grades of Stainless Steel

Sound Pressure Levels (dBa) (measured at 1 meter from unit)

Air Motor	Input Air Pressures at 15 cycles per minute		
	40 psi (0.28 MPa, 2.8 bar)	70 psi (0.48 MPa, 4.8 bar)	100 psi (0.7 MPa, 7 bar)
President	73.6 dB(A)	78.34 dB(A)	80.85 dB(A)
Monark	73.3 dB(A)	75.9 dB(A)	77.7 dB(A)

Sound Power Levels (dBa) (tested in accordance with ISO 9614-2)

Air Motor	Input Air Pressures at 15 cycles per minute		
	40 psi (0.28 MPa, 2.8 bar)	70 psi (0.48 MPa, 4.8 bar)	100 psi (0.7 MPa, 7 bar)
President	87.4 dB(A)	92.09 dB(A)	94.62 dB(A)
Monark	87.0 dB(A)	89.7 dB(A)	91.4 dB(A)

Technical Data

30:1 Ratio President Pumps

To find Fluid Outlet Pressure (psi/MPa/bar) at a specific fluid flow (lpm/gpm) and operating air pressure (psi/MPa/bar):

1. Locate desired flow along bottom of chart.
2. Follow vertical line up to intersection with selected fluid outlet pressure curve (black). Follow left to scale to read fluid outlet pressure.

To find Pump Air Consumption (m³/min or scfm) at a specific fluid flow (lpm/gpm) and air pressure (psi/MPa/bar):

1. Locate desired flow along bottom of chart.
2. Read vertical line up to intersection with selected air consumption curve (dashes). Follow left to scale to read air consumption.

- A 120 psi (0.8 MPa, 8 bar) air pressure
- B 100 psi (0.7 MPa, 7 bar) air pressure
- C 70 psi (0.49 MPa, 4.9 bar) air pressure
- D 40 psi (0.28 MPa, 2.8 bar) air pressure

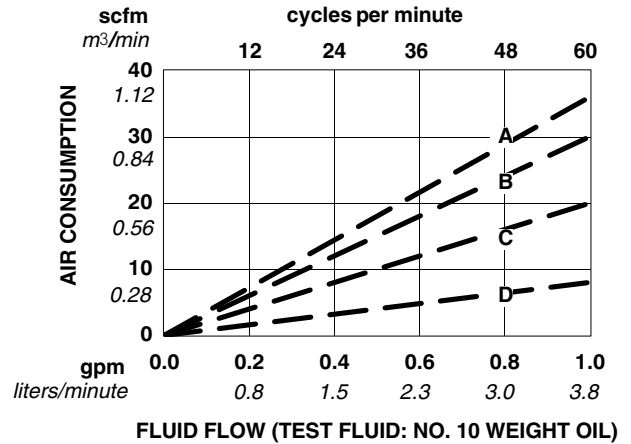
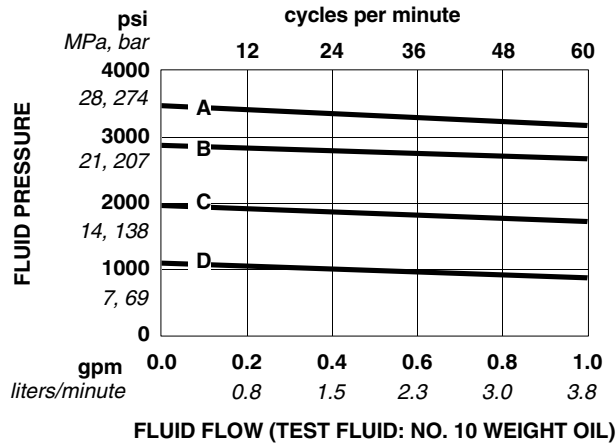

15:1 Ratio Monark Pump

To find Fluid Outlet Pressure (psi/MPa/bar) at a specific fluid flow (lpm/gpm) and operating air pressure (psi/MPa/bar):

1. Locate desired flow along bottom of chart.
2. Follow vertical line up to intersection with selected fluid outlet pressure curve (black). Follow left to scale to read fluid outlet pressure.

To find Pump Air Consumption (m³/min or scfm) at a specific fluid flow (lpm/gpm) and air pressure (psi/MPa/bar):

1. Locate desired flow along bottom of chart.
2. Read vertical line up to intersection with selected air consumption curve (dashes). Follow left to scale to read air consumption.

- A 100 psi (0.7 MPa, 7 bar) air pressure
- B 70 psi (0.49 MPa, 4.9 bar) air pressure
- C 40 psi (0.28 MPa, 2.8 bar) air pressure

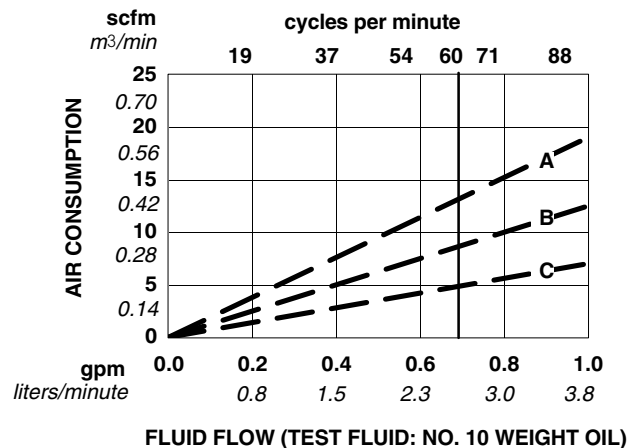
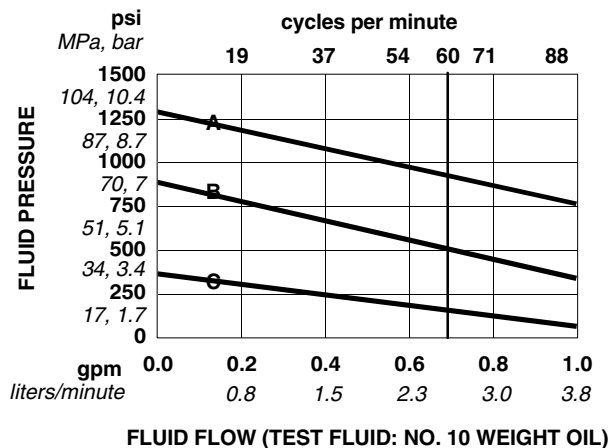

Dimensions

Model 223586 Shown

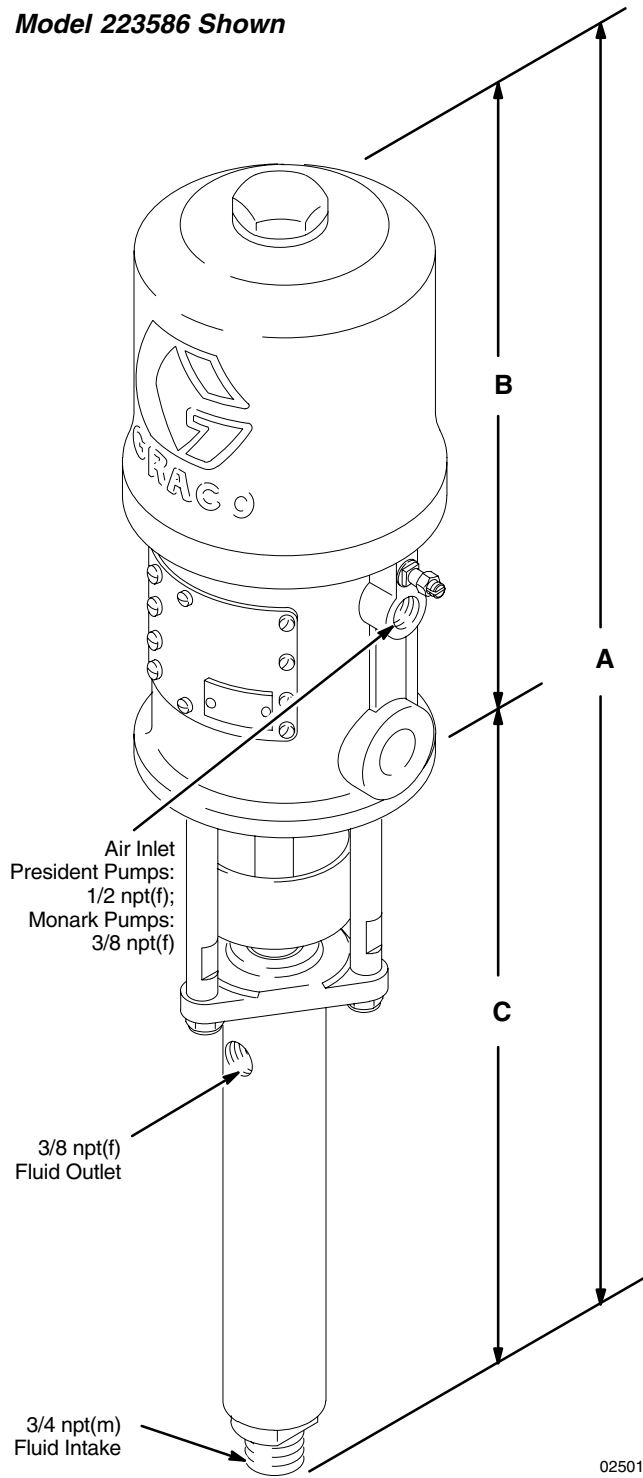

Mounting Hole Layout

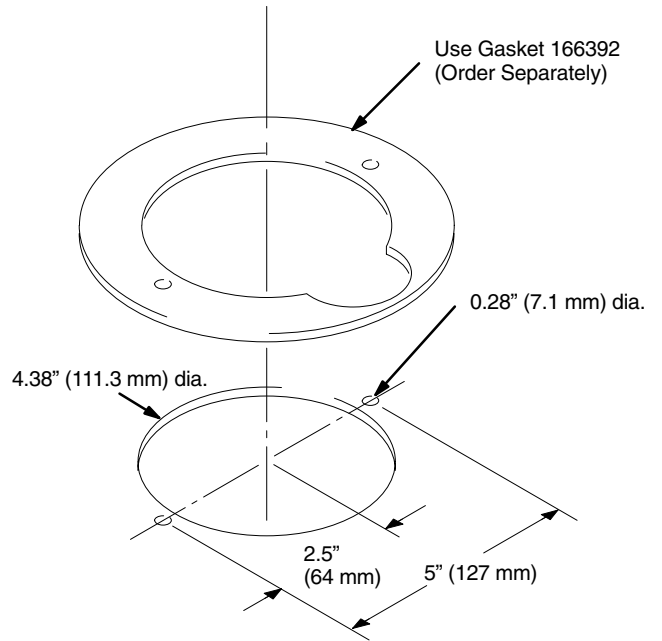

0775

Pump Model	A	B	C
223586	30 in. (762 mm)	15 in. (381 mm)	15 in. (381 mm)
243664			
221075	47 in. (1194 mm)	15 in. (381 mm)	32 in. (810 mm)
239327	28 in. (711 mm)	13 in. (330 mm)	15 in. (381 mm)

Graco Standard Warranty

Graco warrants all equipment manufactured by Graco and bearing its name to be free from defects in material and workmanship on the date of sale to the original purchaser for use. With the exception of any special, extended, or limited warranty published by Graco, Graco will, for a period of twelve months from the date of sale, repair or replace any part of the equipment determined by Graco to be defective. This warranty applies only when the equipment is installed, operated and maintained in accordance with Graco's written recommendations.

This warranty does not cover, and Graco shall not be liable for general wear and tear, or any malfunction, damage or wear caused by faulty installation, misapplication, abrasion, corrosion, inadequate or improper maintenance, negligence, accident, tampering, or substitution of non-Graco component parts. Nor shall Graco be liable for malfunction, damage or wear caused by the incompatibility of Graco equipment with structures, accessories, equipment or materials not supplied by Graco, or the improper design, manufacture, installation, operation or maintenance of structures, accessories, equipment or materials not supplied by Graco.

This warranty is conditioned upon the prepaid return of the equipment claimed to be defective to an authorized Graco distributor for verification of the claimed defect. If the claimed defect is verified, Graco will repair or replace free of charge any defective parts. The equipment will be returned to the original purchaser transportation prepaid. If inspection of the equipment does not disclose any defect in material or workmanship, repairs will be made at a reasonable charge, which charges may include the costs of parts, labor, and transportation.

THIS WARRANTY IS EXCLUSIVE, AND IS IN LIEU OF ANY OTHER WARRANTIES, EXPRESS OR IMPLIED, INCLUDING BUT NOT LIMITED TO WARRANTY OF MERCHANTABILITY OR WARRANTY OF FITNESS FOR A PARTICULAR PURPOSE.

Graco's sole obligation and buyer's sole remedy for any breach of warranty shall be as set forth above. The buyer agrees that no other remedy (including, but not limited to, incidental or consequential damages for lost profits, lost sales, injury to person or property, or any other incidental or consequential loss) shall be available. Any action for breach of warranty must be brought within two (2) years of the date of sale.

Graco makes no warranty, and disclaims all implied warranties of merchantability and fitness for a particular purpose in connection with accessories, equipment, materials or components sold but not manufactured by Graco. These items sold, but not manufactured by Graco (such as electric motors, switches, hose, etc.), are subject to the warranty, if any, of their manufacturer. Graco will provide purchaser with reasonable assistance in making any claim for breach of these warranties.

In no event will Graco be liable for indirect, incidental, special or consequential damages resulting from Graco supplying equipment hereunder, or the furnishing, performance, or use of any products or other goods sold hereto, whether due to a breach of contract, breach of warranty, the negligence of Graco, or otherwise.

FOR GRACO CANADA CUSTOMERS

The parties acknowledge that they have required that the present document, as well as all documents, notices and legal proceedings entered into, given or instituted pursuant hereto or relating directly or indirectly hereto, be drawn up in English. Les parties reconnaissent avoir convenu que la rédaction du présente document sera en Anglais, ainsi que tous documents, avis et procédures judiciaires exécutés, donnés ou intentés à la suite de ou en rapport, directement ou indirectement, avec les procédures concernées.

Graco Information

For the latest information about Graco products, visit www.graco.com.

TO PLACE AN ORDER, contact your Graco distributor, or call one of the following numbers to identify the distributor closest to you:

1-800-328-0211 Toll Free

612-623-6921

612-378-3505 Fax

All written and visual data contained in this document reflects the latest product information available at the time of publication. Graco reserves the right to make changes at any time without notice.

This manual contains English. MM 306981

Graco Headquarters: Minneapolis

International Offices: Belgium, China, Japan, Korea

GRACO INC. P.O. BOX 1441 MINNEAPOLIS, MN 55440-1441

Copyright 1991, Graco Inc. is registered to ISO 9001

www.graco.com

Revised 07/2009

Free Manuals Download Website

<http://myh66.com>

<http://usermanuals.us>

<http://www.somanuals.com>

<http://www.4manuals.cc>

<http://www.manual-lib.com>

<http://www.404manual.com>

<http://www.luxmanual.com>

<http://aubethermostatmanual.com>

Golf course search by state

<http://golfingnear.com>

Email search by domain

<http://emailbydomain.com>

Auto manuals search

<http://auto.somanuals.com>

TV manuals search

<http://tv.somanuals.com>